

PARIS 1 DRAWER BEDSIDE ASSEMBLY INSTRUCTIONS

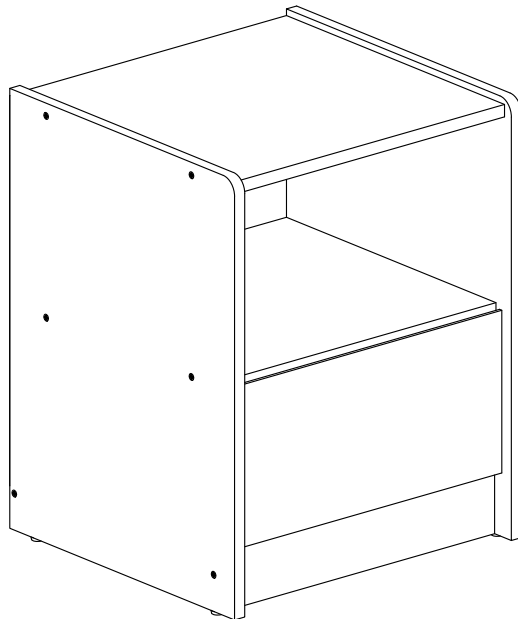

FOR DOMESTIC USE ONLY IMPORTANT PLEASE READ BEFORE YOU CONTINUE FURTHER

THE PRODUCT YOU HAVE PURCHASED WILL GIVE YOU MANY YEARS OF SERVICE IF YOU FOLLOW THE GUIDELINES FOR ITS SAFE ASSEMBLY AND PERIODIC MAINTENANCE AND CLEANING.

ASSEMBLE ON A SOFT CLEAN SURFACE.

DO NOT USE ANY TOOLS OTHER THAN THOSE SHOWN.

ANY SPANNERS OR ALLEN KEYS REQUIRED ARE INCLUDED WITH THE FITTING KIT.

DO NOT FOR ANY REASON USE A POWER TOOL TO ASSEMBLE THIS PRODUCT. ITS USE WILL INVALIDATE ANY CLAIM YOU MAY HAVE AND COULD MAKE THIS PRODUCT UNSAFE.

DEPENDING ON THE AMOUNT OF USE THIS PRODUCT RECEIVES, IT MAY BE NECESSARY TO TIGHTEN UP THE FIXINGS FROM TIME TO TIME. THIS IS COMPLETELY NORMAL FOR ANY FLAT PACK FURNITURE .

FOR CLEANING, YOU MAY USE A DAMP CLOTH (NOT WET). DO NOT USE POLISH, DETERGENT OR CHEMICAL CLEANERS.



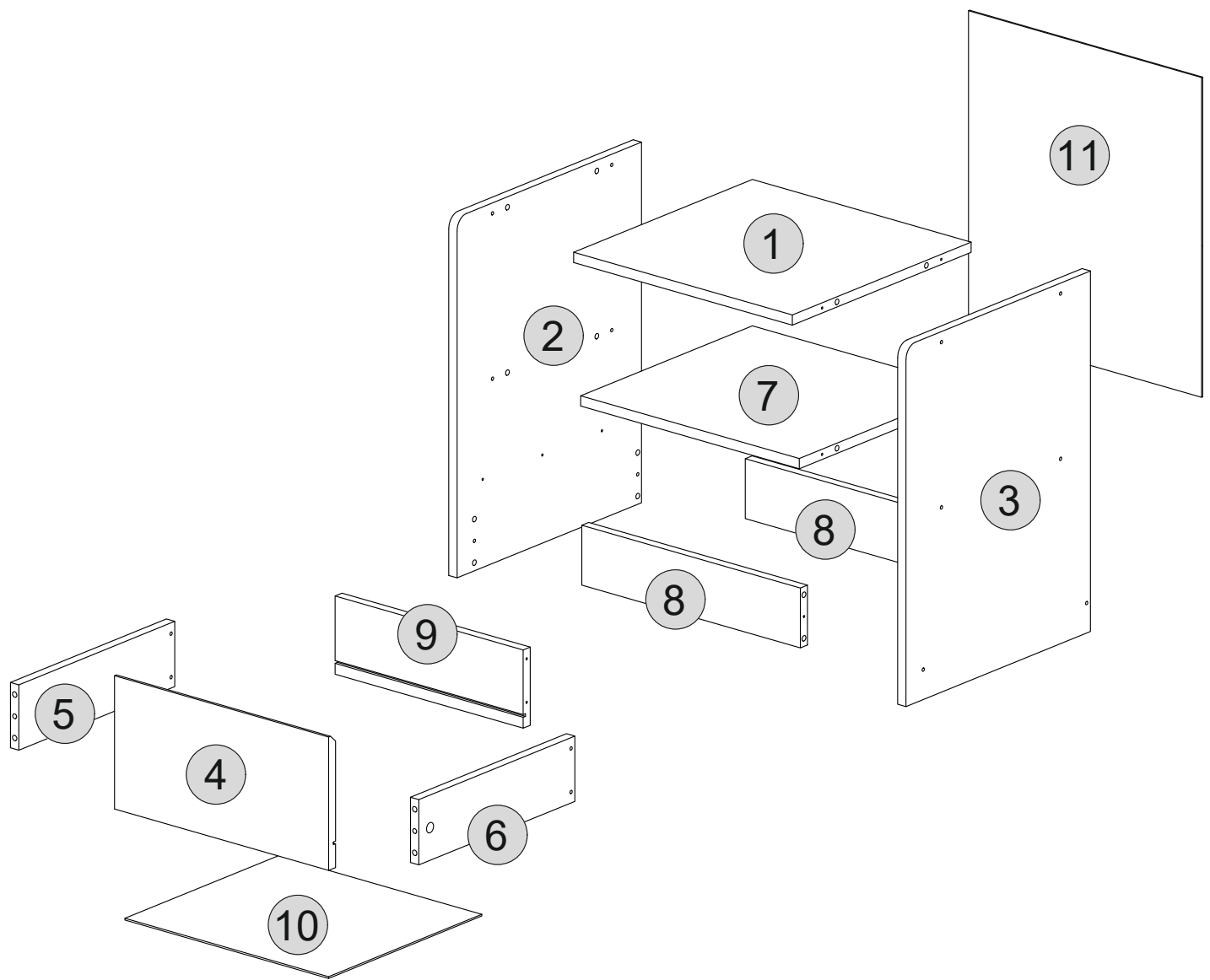



THIS SURFACE OF THIS ITEM IS NOT HEAT RESISTANT. ALWAYS USE A PLACE MAT UNDER HOT OR COLD ITEMS TO PREVENT MARKING.

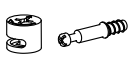

PART LIST

<u>Part Number</u>	<u>Part Code</u>	<u>Part Description</u>	<u>Quantity</u>	<u>Carton</u>
1	S100-103-101-FM1-01	Top Panel	1	1/1
2	S100-103-101-FM1-02	Side Panel (Left)	1	1/1
3	S100-103-101-FM1-03	Side Panel (Right)	1	1/1
4	S100-103-101-FM1-04	Drawer Front	1	1/1
5	S100-103-101-FM1-05	Drawer Side Panel (Left)	1	1/1
6	S100-103-101-FM1-06	Drawer Side Panel (Right)	1	1/1
7	S100-103-101-FM1-07	Shelf Panel	1	1/1
8	S100-103-101-FM1-08	Crossbar Panel	2	1/1
9	S100-103-101-FM1-09	Drawer Back Board	1	1/1
10	S100-103-101-FM1-10	Drawer Bottom Panel	1	1/1
11	S100-103-101-FM1-11	Back Panel	1	1/1

HARDWARE LIST

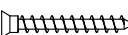
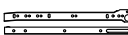
No	Part Name		Qty	Carton
DW6	Wooden Dowel 8 x 25mm		20 Pcs	1/1
LG1	Plastic Foot		4 Pcs	1/1
MF2	Nail		20 Pcs	1/1
MN2	Mini Fix 15mm		2 Sets	1/1
PF2	Single Plastic Cap		2 Pcs	1/1
SC3	Screw M3.5 x 14mm		16 Pcs	1/1
SC18	Screw M4 x 38mm		4 Pcs	1/1
SC25	FH Screw M5 x 40mm		12 Pcs	1/1
SL7	Drawer Metal Slide 350mm		1 Set	1/1

TIPS FOR FITTINGS CAM-LOCKS

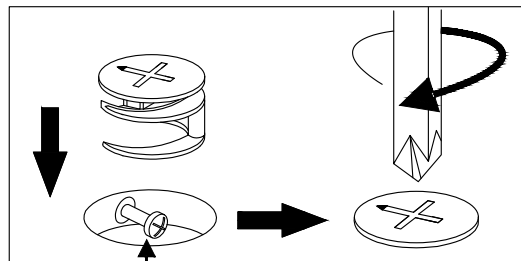
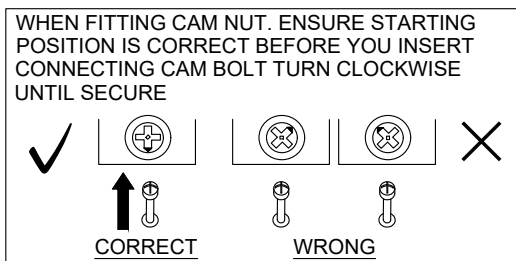

Cam bolt head needs to be in centre

CAMBOLT

Tighten until shoulder in flush with panel. Do not overtighten or undertighten (see example below)

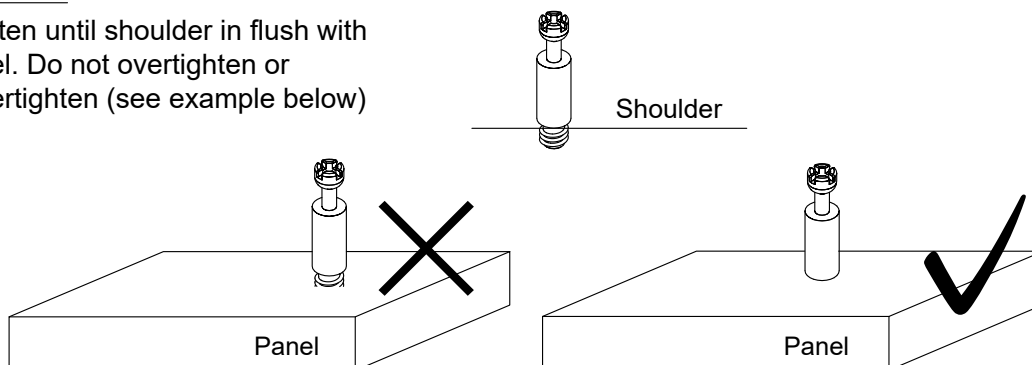

PLEASE CHECK THAT YOU HAVE ALL THE PARTS LISTED BEFORE YOU START ASSEMBLING, IF YOU DO FIND THAT SOMETHING IS MISSING, DO NOT CONTINUE ASSEMBLY. PLEASE CONTACT YOUR SUPPLIER IMMEDIATELY.

STEP 1

PARTS REQUIRED

- 1 - TOP PANEL x1
- 7 - SHELF PANEL x1
- 8 - CROSSBAR PANEL x2

HARDWARE REQUIRED

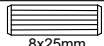
- DW6  16

TOOLS REQUIRED

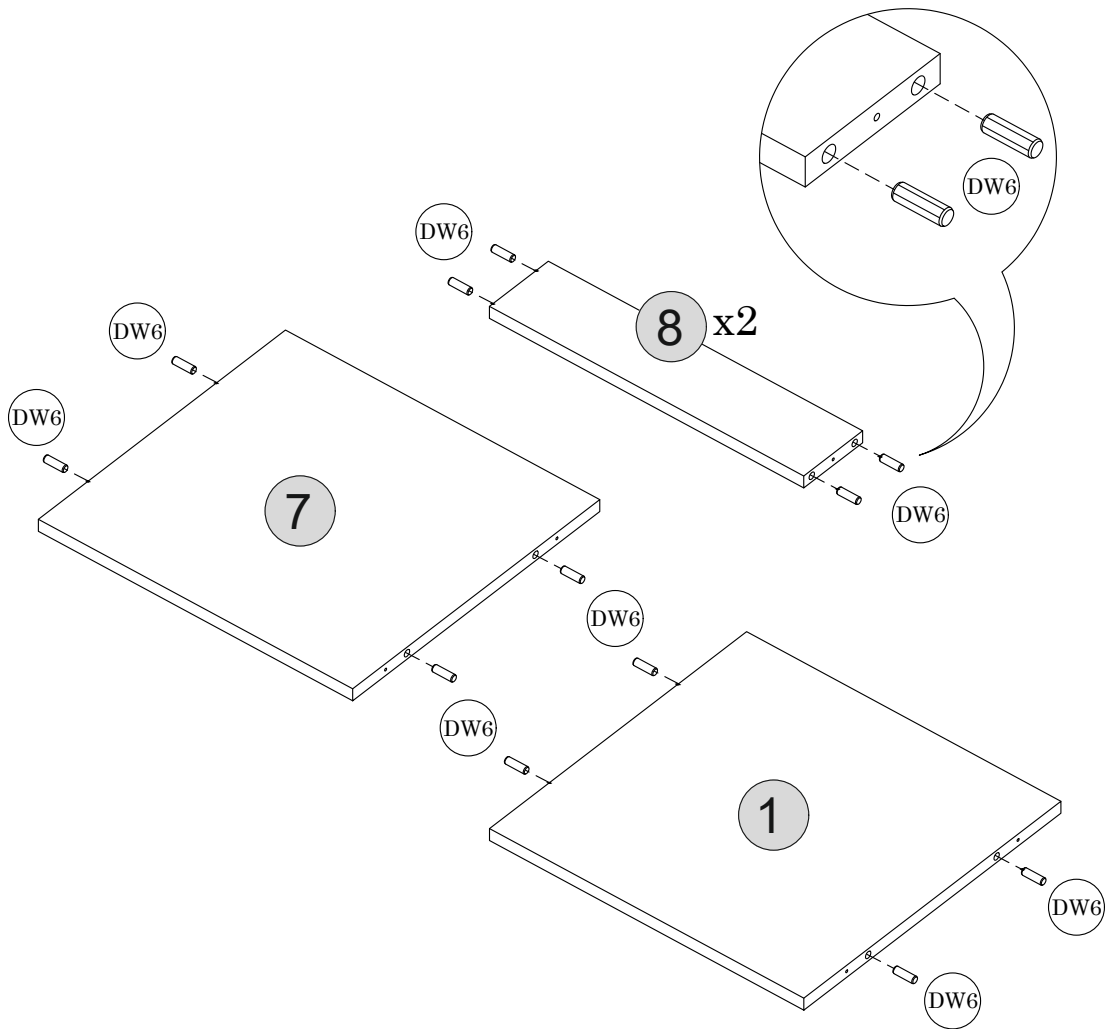
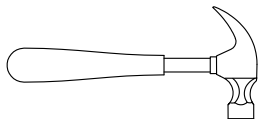

STEP 2

PARTS REQUIRED

- 2 - SIDE PANEL (LEFT) x1
- 3 - SIDE PANEL (RIGHT) x1

HARDWARE REQUIRED

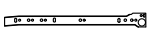
- SC3  06
- SL7  01

TOOLS REQUIRED

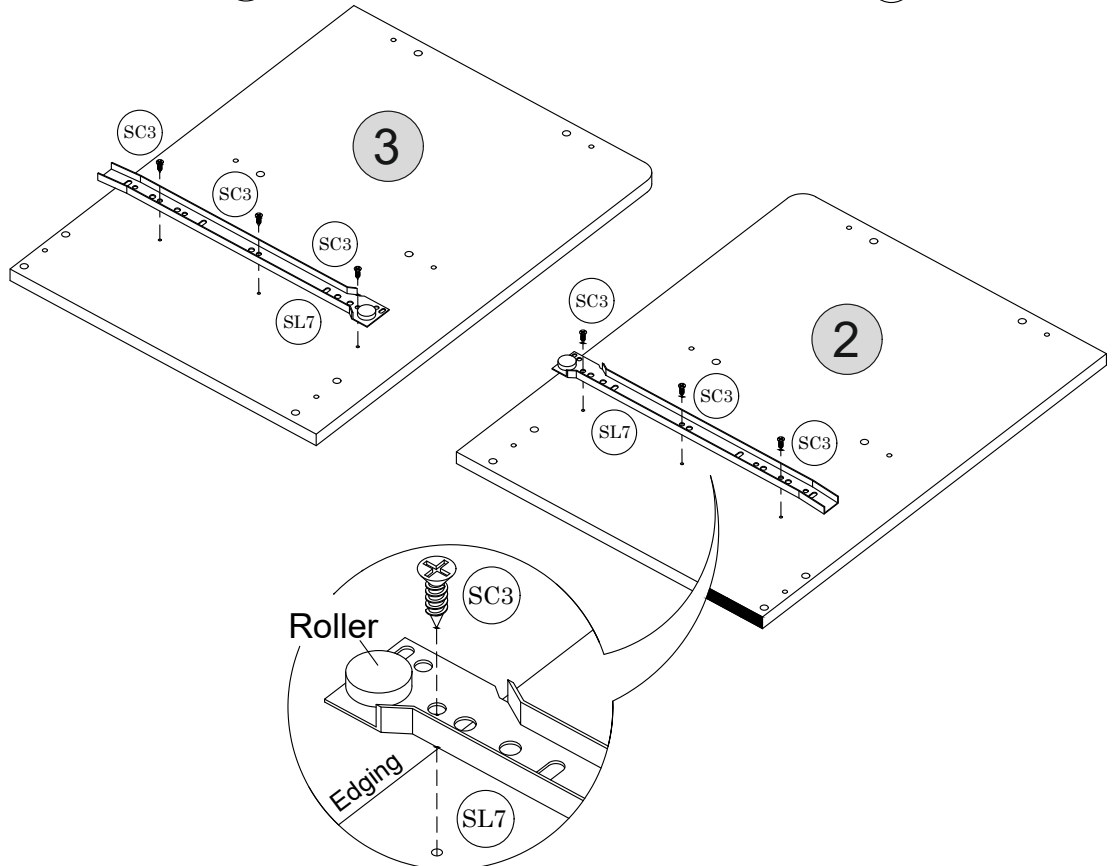
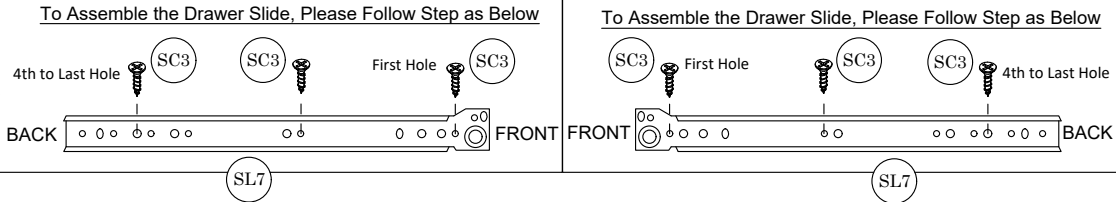
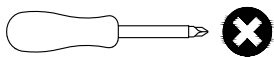

STEP 3

PARTS REQUIRED

- 1 - TOP PANEL x1
- 3 - SIDE PANEL (RIGHT) x1
- 7 - SHELF PANEL x1

HARDWARE REQUIRED

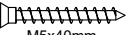
SC25  04
M5x40mm

TOOLS REQUIRED

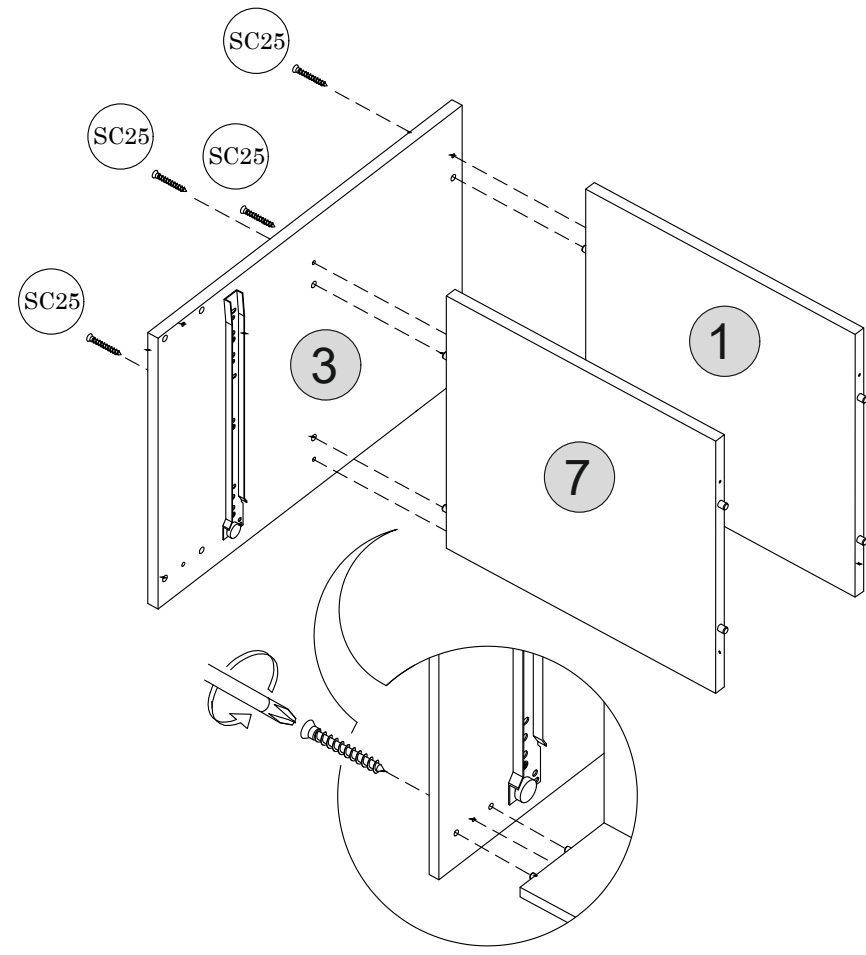
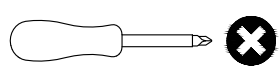

STEP 4

PARTS REQUIRED

- 2 - SIDE PANEL (RIGHT) x1
- 8 - CROSSBAR PANEL x2

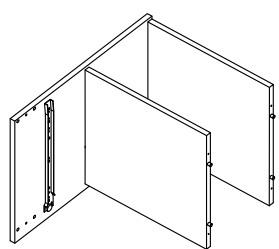

HARDWARE REQUIRED

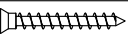
SC25  08
M5x40mm

TOOLS REQUIRED

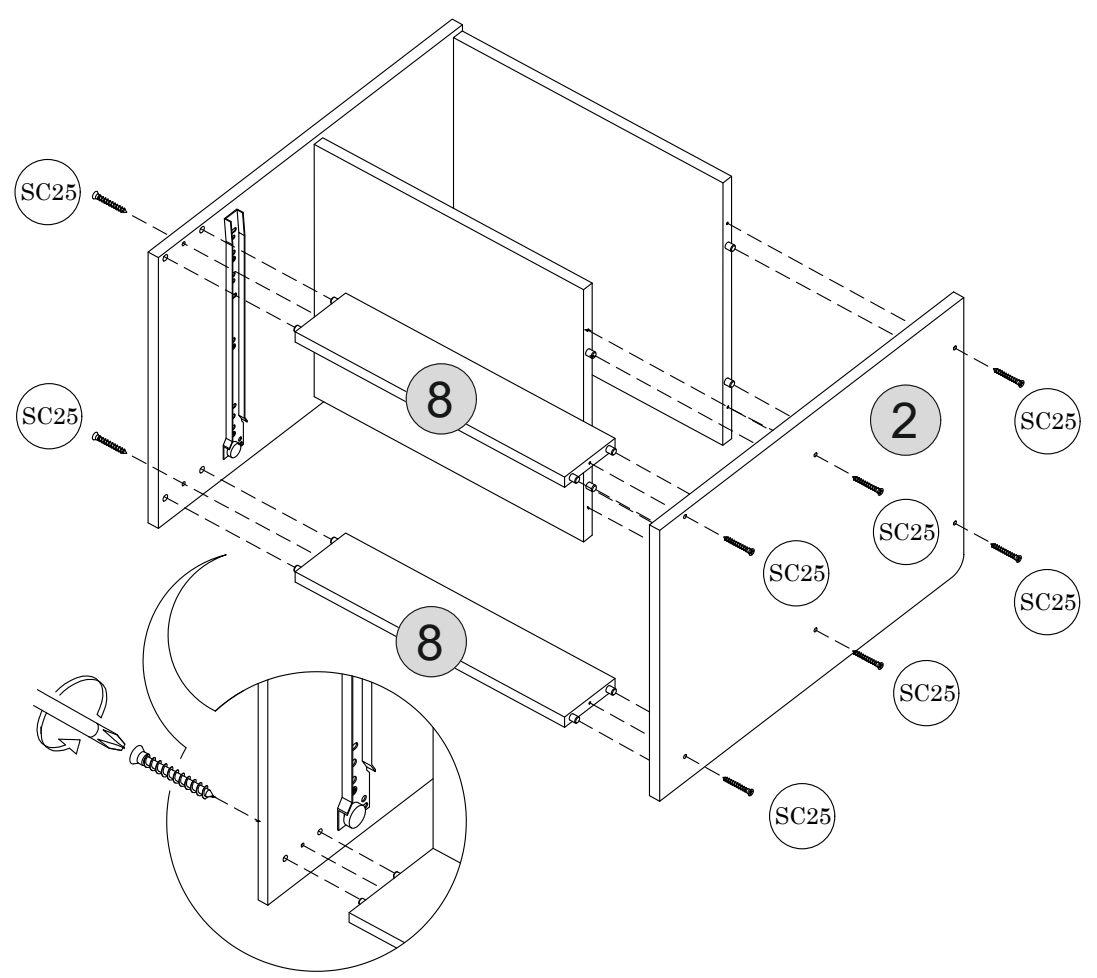
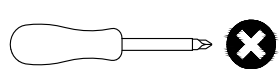

STEP 5

PARTS REQUIRED

11-BACK PANEL x1

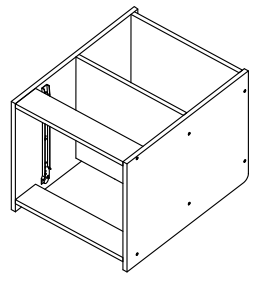

HARDWARE REQUIRED

MF2  14

TOOLS REQUIRED

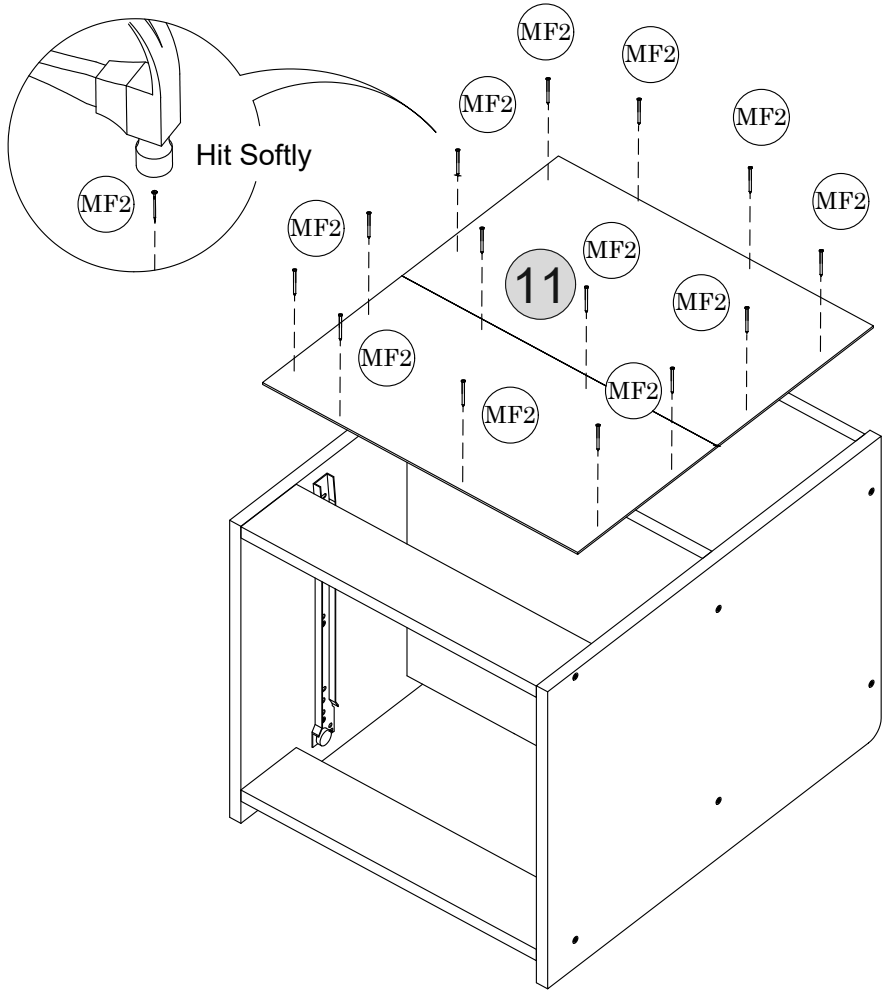
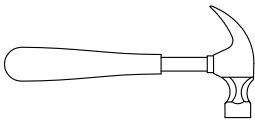

STEP 6

PARTS REQUIRED

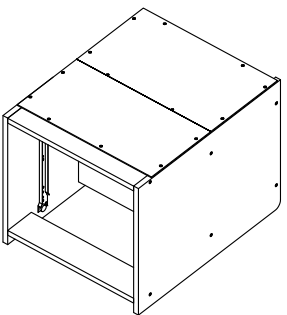

HARDWARE REQUIRED

LG1  04

SC3  02

TOOLS REQUIRED

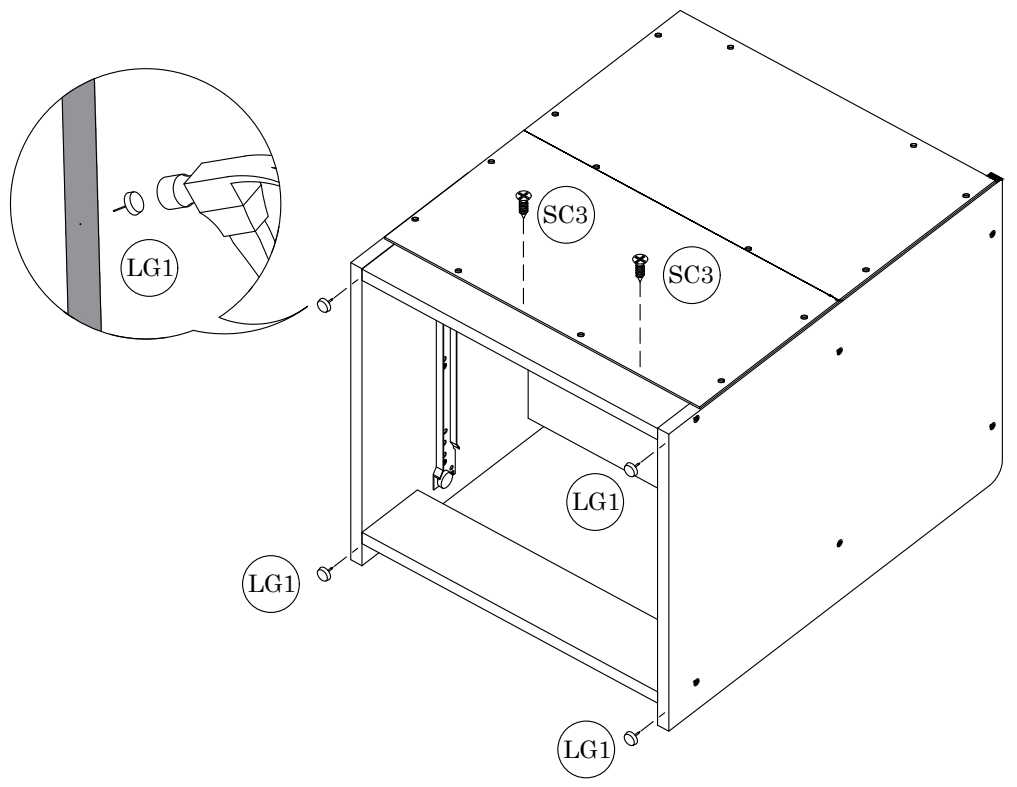
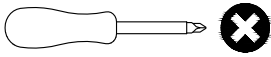
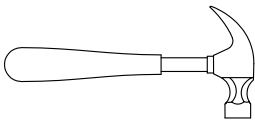

STEP 7

PARTS REQUIRED

4 - DRAWER FRONT x1

5 - DRAWER SIDE (LEFT) x1

6 - DRAWER SIDE (RIGHT) x1

HARDWARE REQUIRED

DW6  04

MN2  02

MN2  02

TOOLS REQUIRED

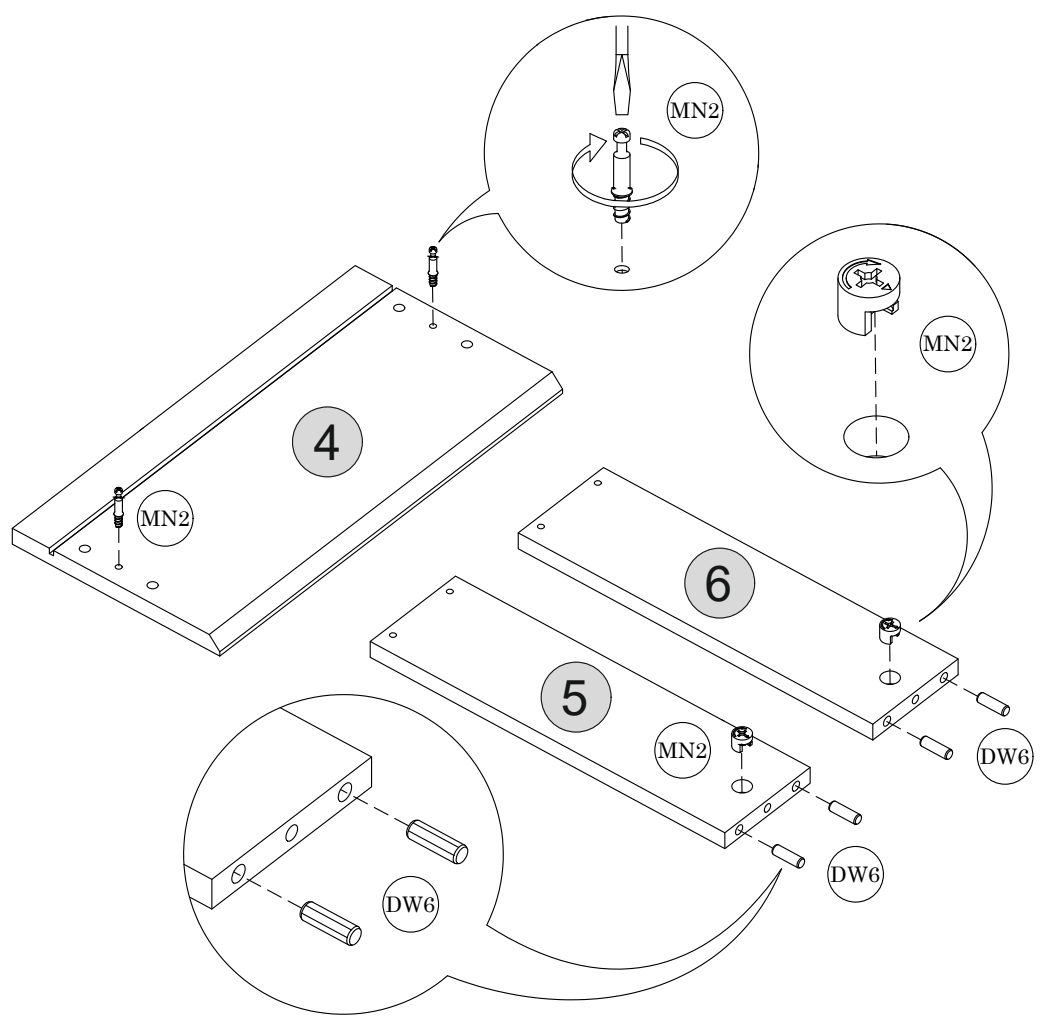
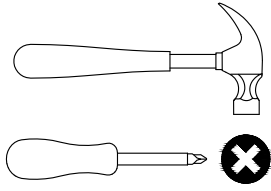

STEP 8

PARTS REQUIRED

5 - DRAWER SIDE (LEFT) x1

6 - DRAWER SIDE (RIGHT) x1

9 - DRAWER BACKBOARD x1

HARDWARE REQUIRED

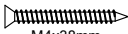
SC18  04

TOOLS REQUIRED

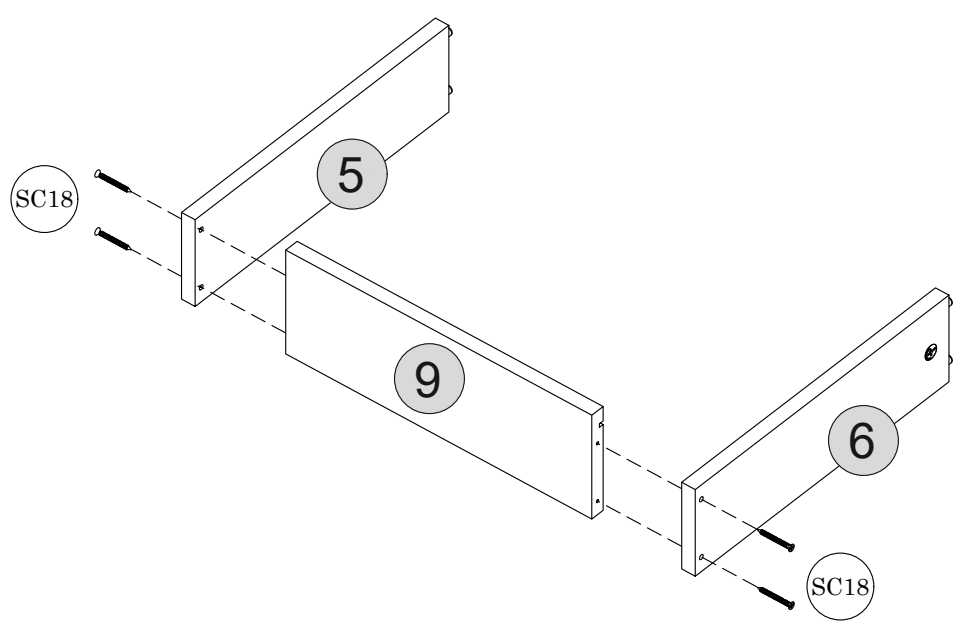
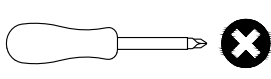

STEP 9

PARTS REQUIRED

- 4 - DRAWER FRONT x1
- 10- DRAWER BOTTOM PANEL x1

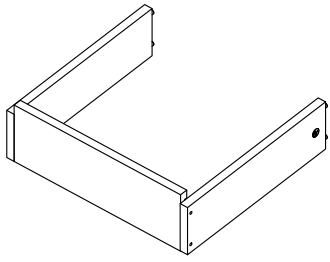

HARDWARE REQUIRED

- MF2  06

TOOLS REQUIRED

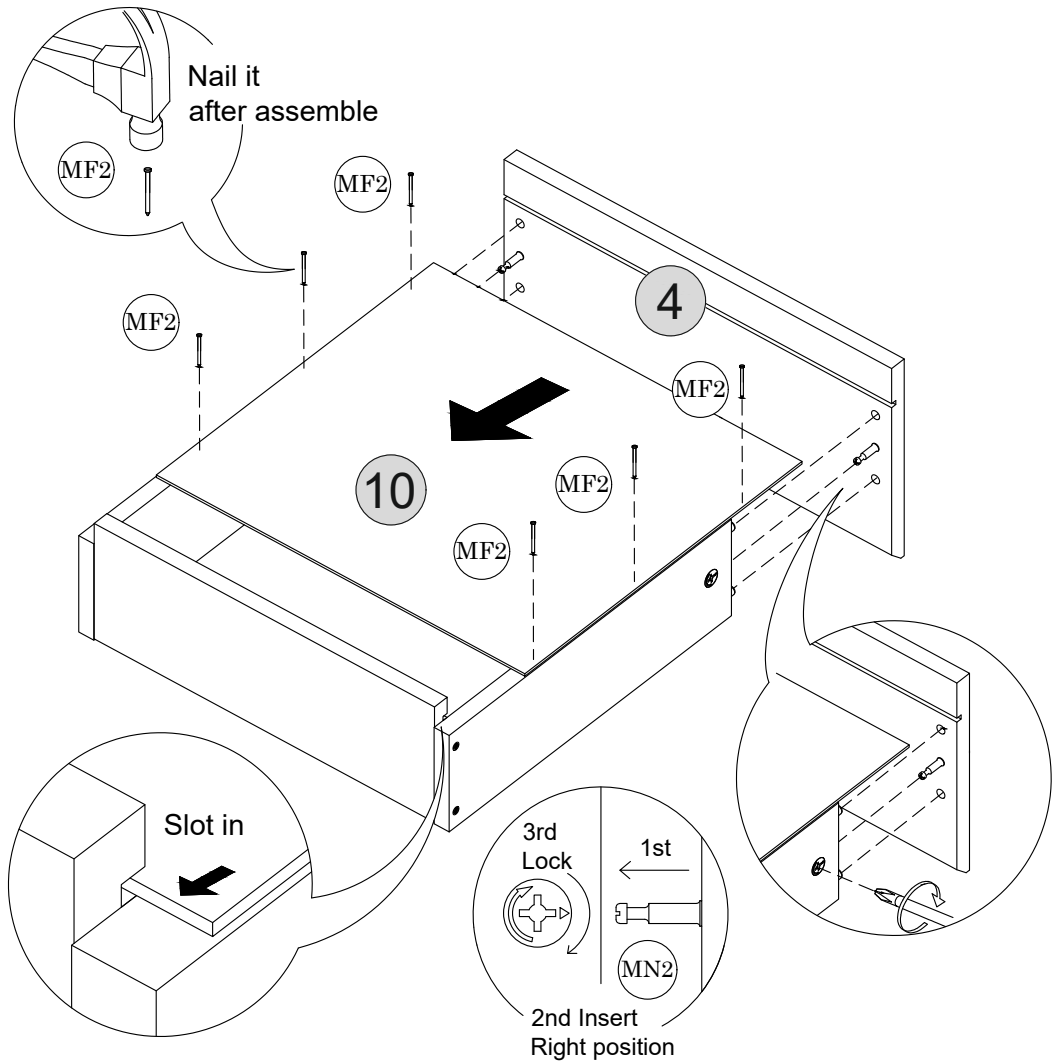
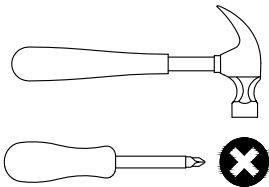

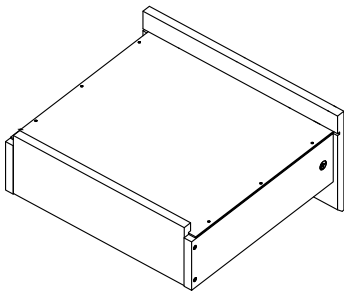

STEP 10

PARTS REQUIRED



HARDWARE REQUIRED

- PF2  02
- SC3  02

TOOLS REQUIRED

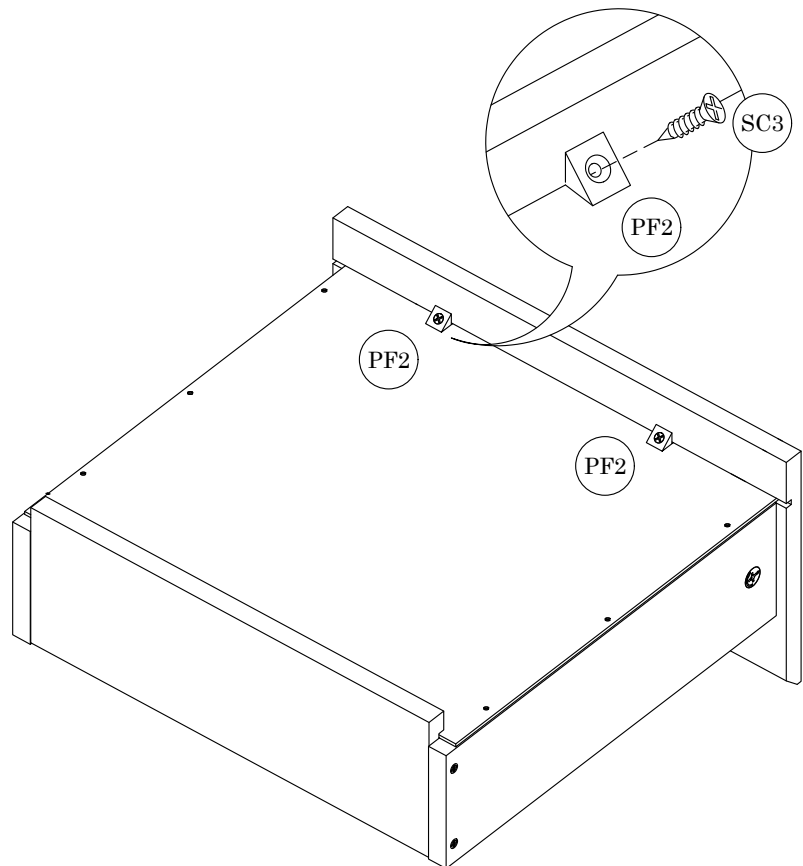
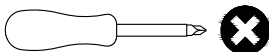

STEP 11

PARTS REQUIRED

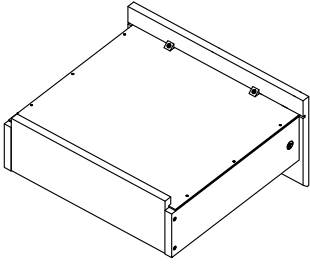

HARDWARE REQUIRED

SC3  06

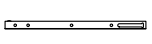
SL7  01

TOOLS REQUIRED

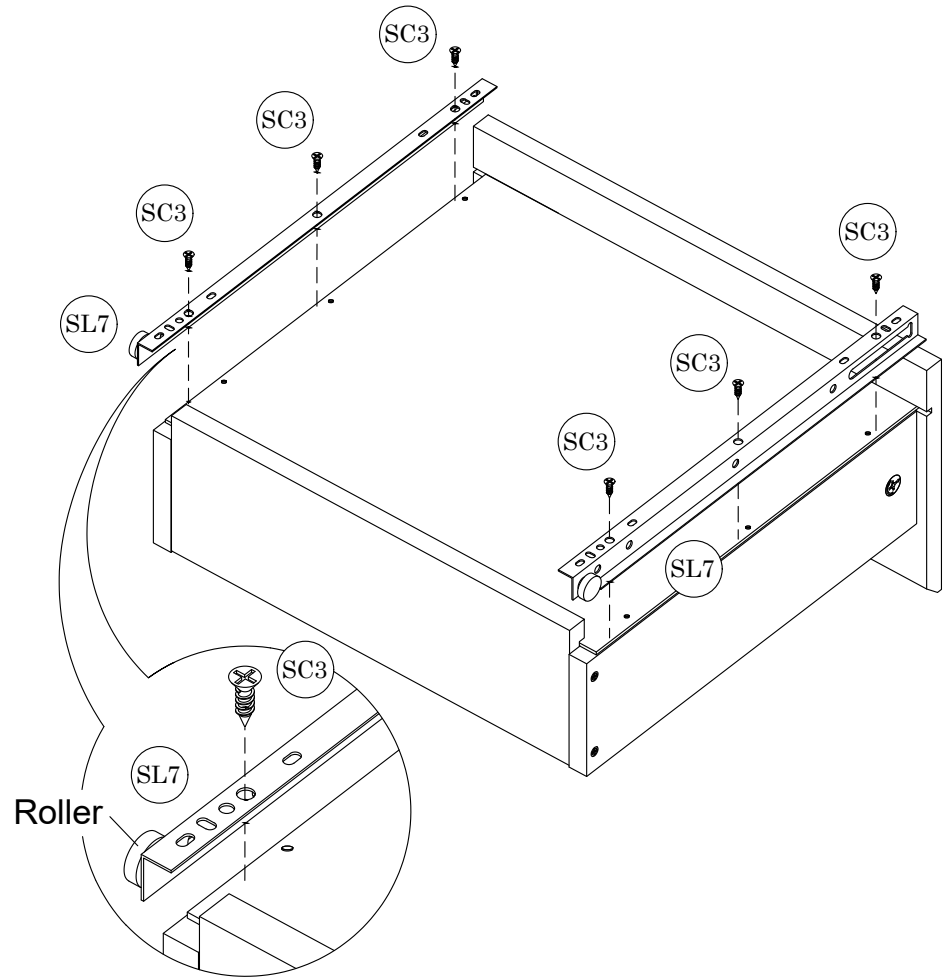
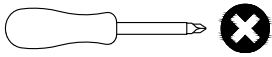

STEP 12

PARTS REQUIRED

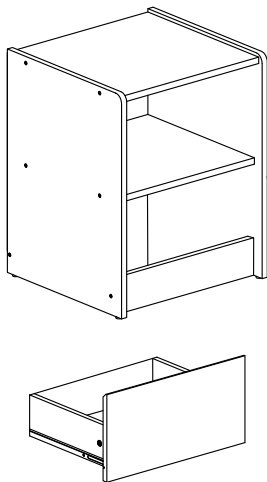

HARDWARE REQUIRED

TOOLS REQUIRED

