

Birlea®

Assembly Instructions

Thank you for
purchasing a
Birlea product

For a chance to win a Love2Shop voucher simply post a picture of your new product on your preferred social channels tagging Birlea Furniture. One winner will be selected at random each month.

*Terms & conditions may apply.

Are you happy with your purchase?

Yes: That's great, we would love to hear more from you. Please leave us a review on our Trustpilot link on the QR code here. Your feedback will be greatly appreciated.



No: If for any reason there is something missing, indifferent or incorrect with your order, please contact the retailer that you purchased your item from.

Please note that this items build time is around : 60mins



www.birlea.com

ASSEMBLY INSTRUCTIONS
HERRINGFORD 2 DOOR 1 DRAWER WARDROBE

IMPORTANT : READ THESE INSTRUCTIONS CAREFULLY BEFORE ATTEMPTING TO ASSEMBLE OR USE YOUR HERRINGFORD 2 DOOR 1 DRAWER WARDROBE.

PLEASE KEEP THESE INSTRUCTIONS FOR FUTURE REFERENCE.

ASSEMBLY:

Assembly should be carried out with this item laying flat, not standing upright.
Assemble on a soft, clean surface to prevent damages.
To erase the numbers printed on the pieces, use the rubber inside the accessories pack.

HEALTH & SAFETY:







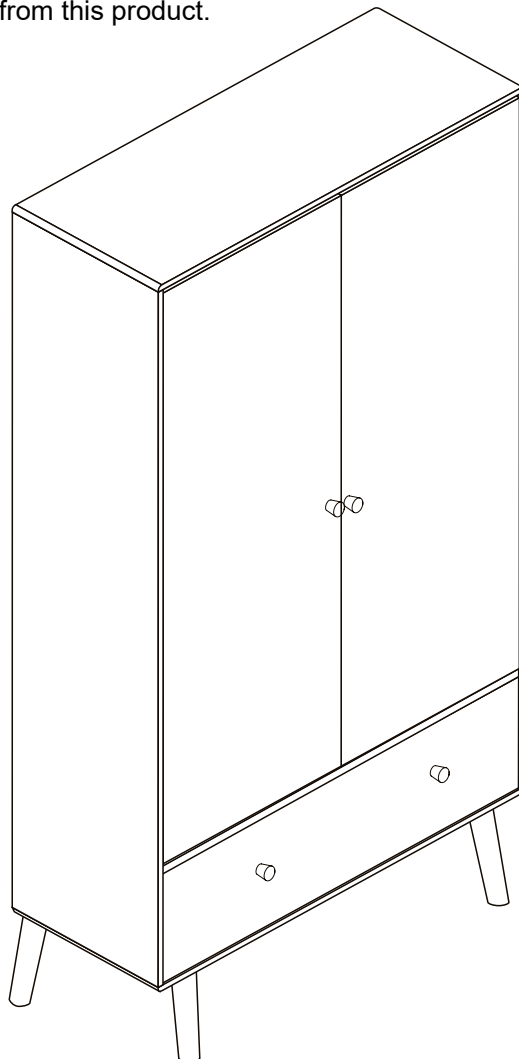

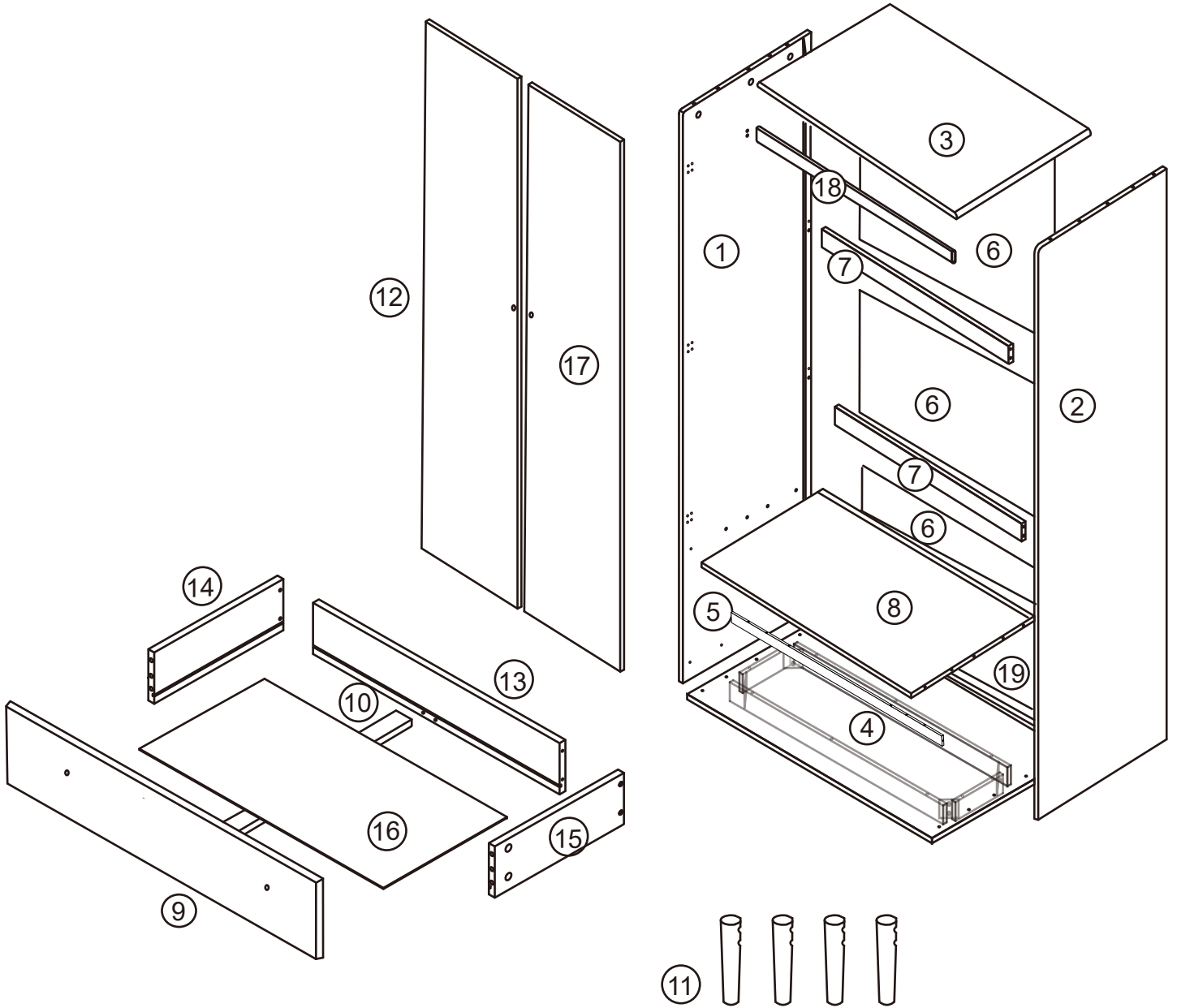

















DO NOT use this product if any parts are missing, damaged or worn.
DO NOT use this product unless all fixings are secured.
Always use on a level, even surface.

CARE & MAINTENANCE:

Periodically check all screws & fixings to ensure they are secure.
DO NOT push this product as this will cause damage.
Always lift this product with two people to repositions.
Keep any sharp objects away from this product.





Parts List				Hardware List		
Part	Description	Box	Qty	Part	Description	Qty
1	Side Panel(Left)	1	1	A	Cam Bolt 	25
2	Side Panel(Right)	1	1	B	Cam Lock 	25
3	Top Panel	2	1	C	Wooden Dowel 	19
4	Bottom Panel	2	1	D	Screw 	6
5	Support bar	2	1	E	Tube bracket 	2
6	Back Panel	2	3	F	Screw 	2
7	Back Rail	2	2	G	Screw  3x12mm	12
8	Middle Divider	2	1	H	Handle set 	4
9	Drawer Front	2	1	I	Plastic Wedge Set 	16
10	Drawer Support Rail	2	1	J	Screw 	6
11	Wooden Leg	2	4	K	Hole Sticker 	10
12	Door panel(Left)	1	1	L	Allen key 	1
13	Drawer Back	2	1	M	Washer 	2
14	Drawer Side(Left)	2	1	N	Safe Strap 	2
15	Drawer Side(Right)	2	1	O	Foot Pad 	4
16	Drawer Bottom	2	1	P	Screw 	4
17	Door panel(Right)	1	1	Q	Screw   	8
18	Hanging	2	1	R	Magnetic Door Holder 	1
19	Back Panel	2	1	S	Metal Door Holder 	2
				T	Hinges 	6
				U	Screw  4x14mm	40
				DL	Rail 	1
				DR	Rail 	1
				CL	Rail 	1
				CR	Rail 	

** You will need a small mallet and a screwdriver for assembly.

** Some screws and wooden dowel may remain.

** Note : To secure the item to the wall.

Step 1: Assemble drawer side panel(14),(15),drawer back(13)and drawer support rail(10) by hardware D;
 Attach the drawer bottom panel (16);Then,assemble the drawer front panel(9) by hardwareA,B,C,K;
 Then,attach the handle H. Assemble hardware (DR), (DL) by hardware G.

DO NOT use any power tools as this may damage the frame and will invalidate any claim.

AX5
BX5
CX3
DX6
GX6
HX2
KX4
DRX1
DLX1

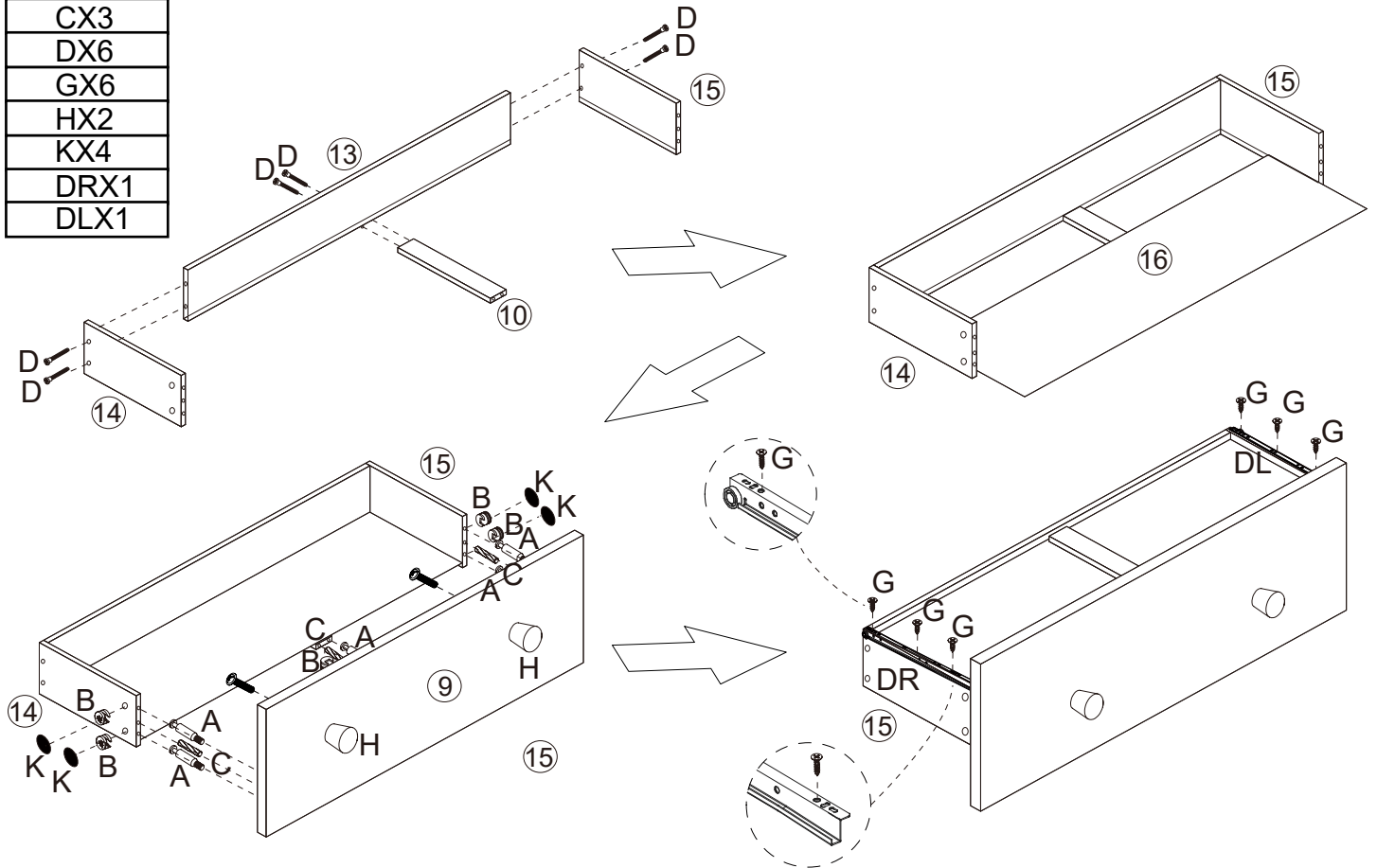

Step 2: Assemble hardware(CL),(CR) on side panels(1),(2) by hardware G; Then attach the hardware A on both panels; Then, assemble hardware E by hardware U.

DO NOT use any power tools as this may damage the frame and will invalidate any claim.

AX14
EX2
GX6
CLX1
CRX1
UX4

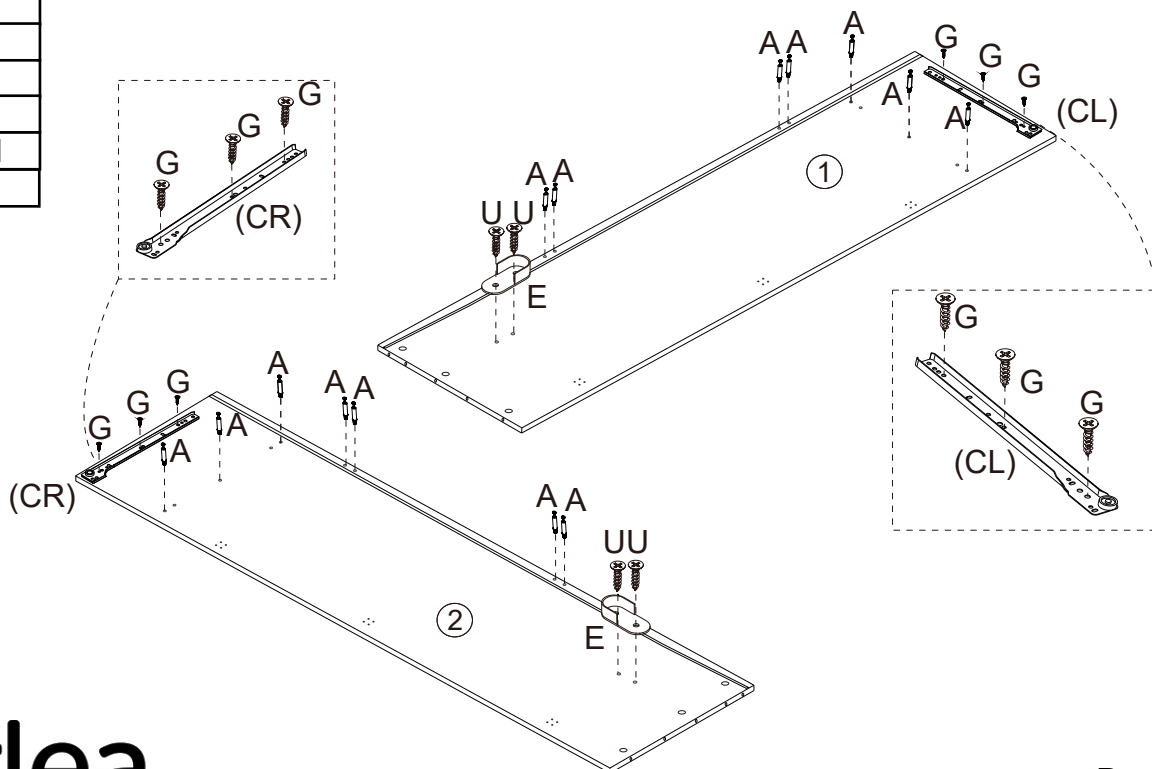

Step 3: Assemble the support bar(5) with middle divider(8) by hardware C,P;

Then, assemble two back rail(7) on side panel (1) by hardware B;

Assemble the support bar(5) with side panel (1) by hardware C;

Assemble the middle divider (8) with side panel(1) by hardware B,C.

DO NOT use any power tools as this may damage the frame and will invalidate any claim.

BX7
CX5
PX4

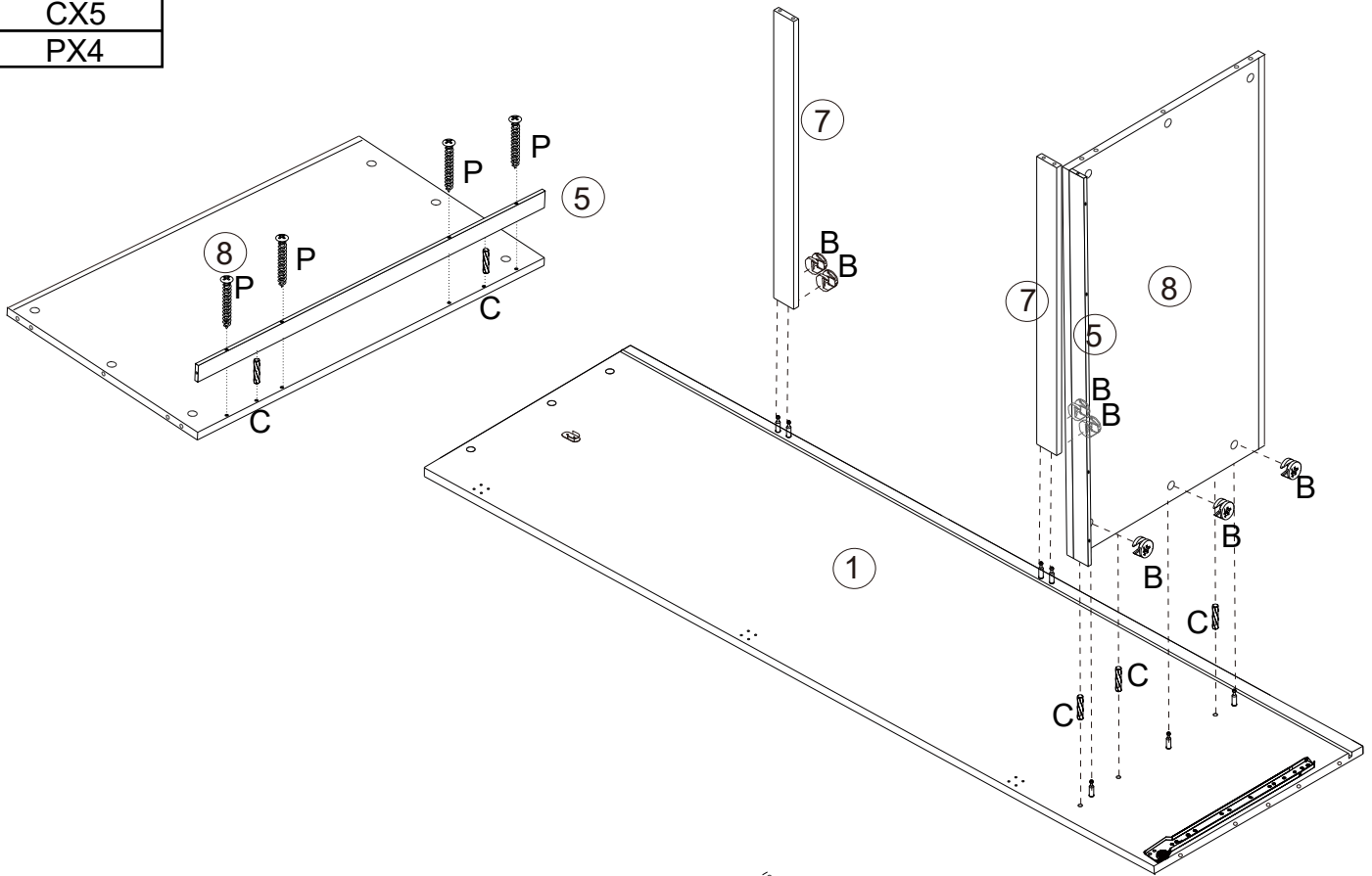

Step 4: Attach two back panel(6).

DO NOT use any power tools as this may damage the frame and will invalidate any claim.

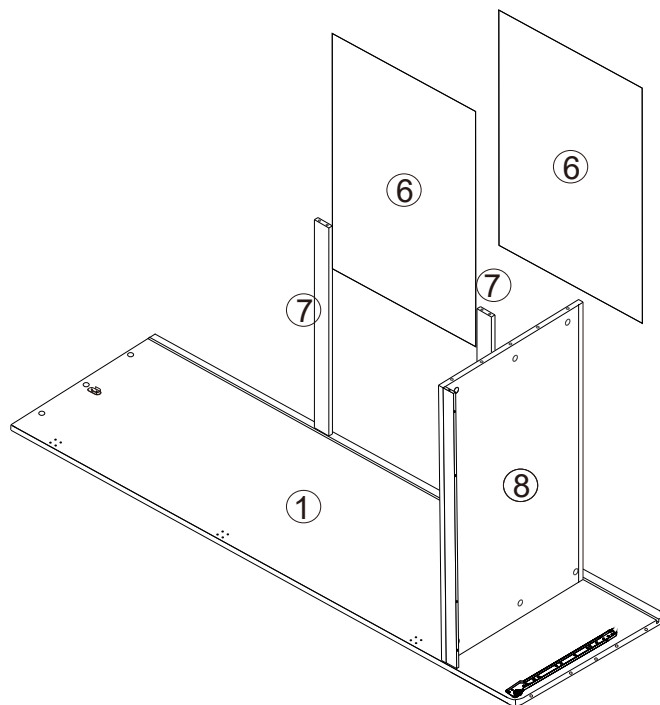

Step 5: Assemble the right side panel(2) by hardware B,C.

DO NOT use any power tools as this may damage the frame and will invalidate any claim.

BX7
CX3

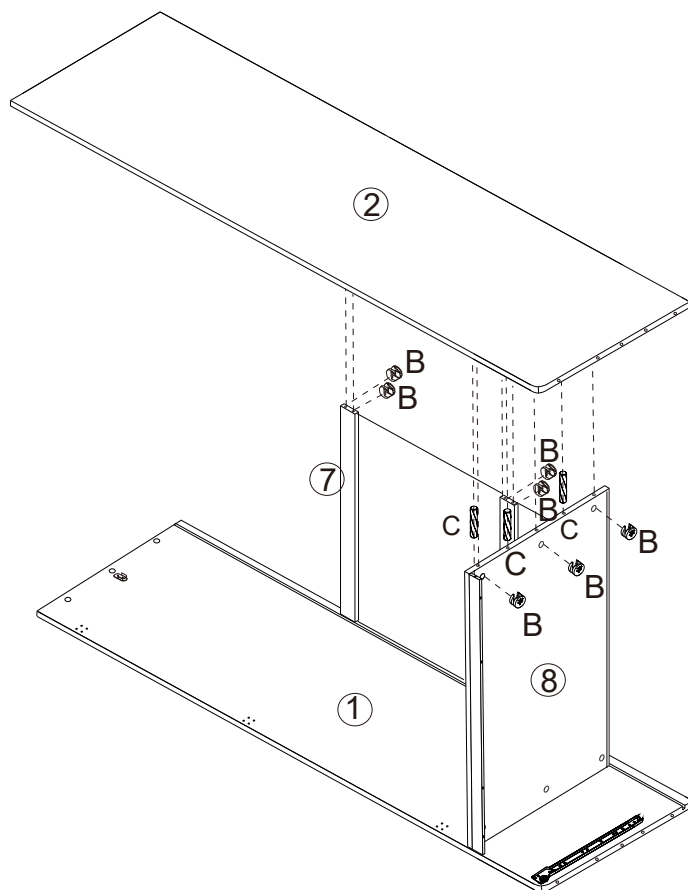

Step 6: Attach the back panel(6),(19).

DO NOT use any power tools as this may damage the frame and will invalidate any claim.

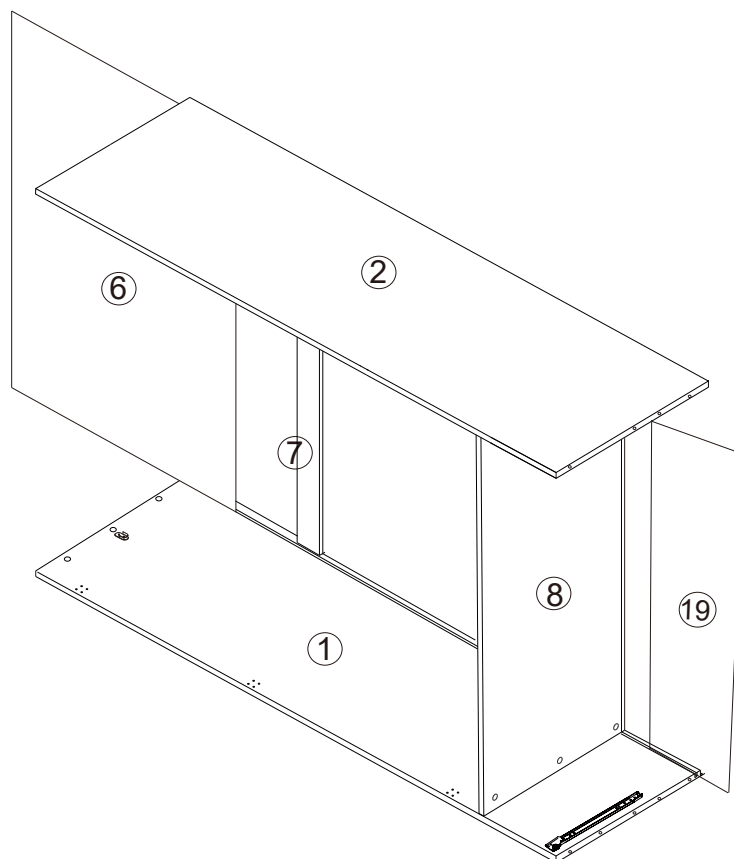

Step 7: Attach hardware A on top panel(3);Then,attach hardware(R) on top panel(3).

Attach the top panel (3) with frame by hardware B,C,K.

DO NOT use any power tools as this may damage the frame and will invalidate any claim.

AX6
BX6
CX4
KX6
RX1

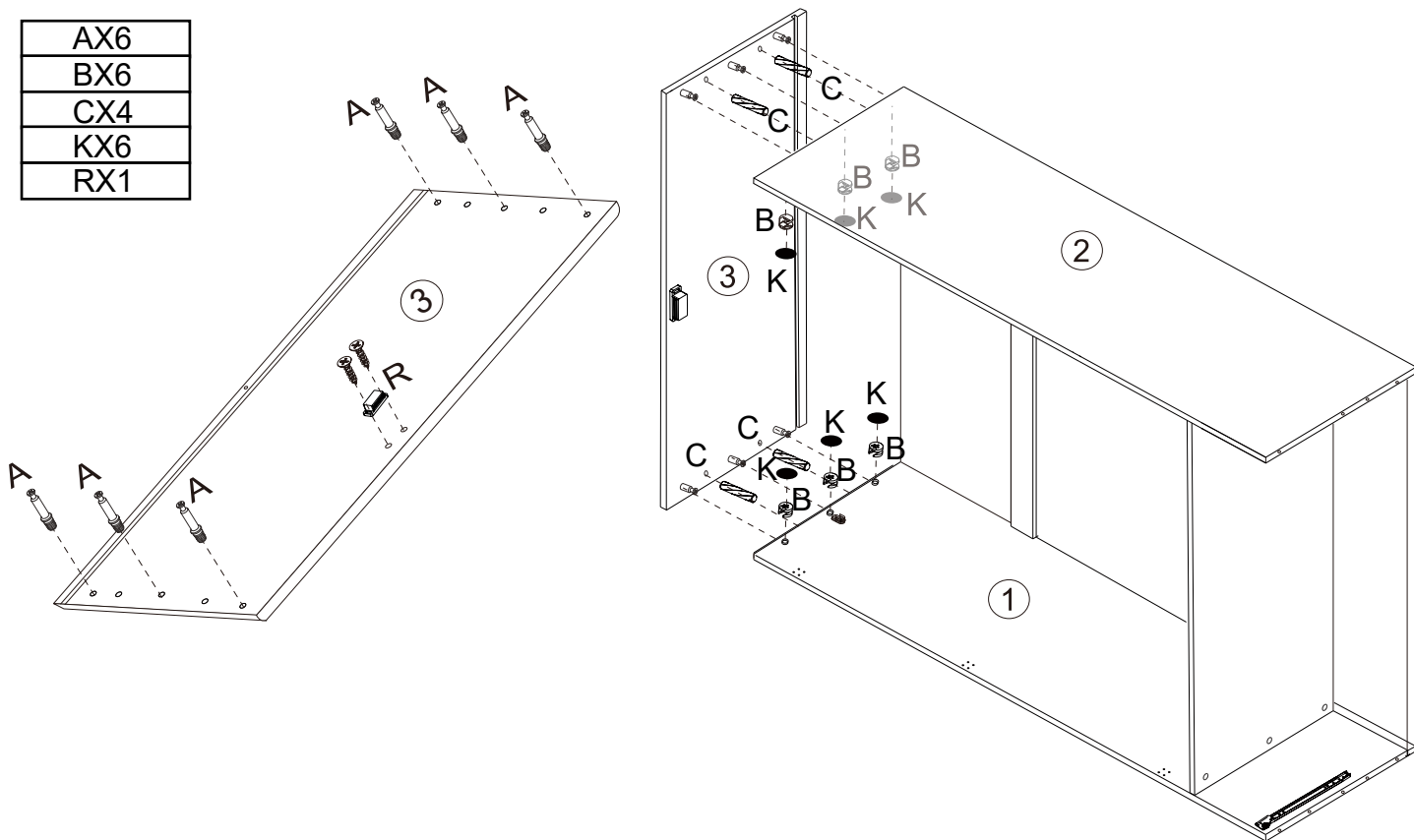

Step 8: Assemble the leg(11) with base frame (4) by hardware L,Q,O.

DO NOT use any power tools as this may damage the frame and will invalidate any claim.

LX1
OX4
QX8

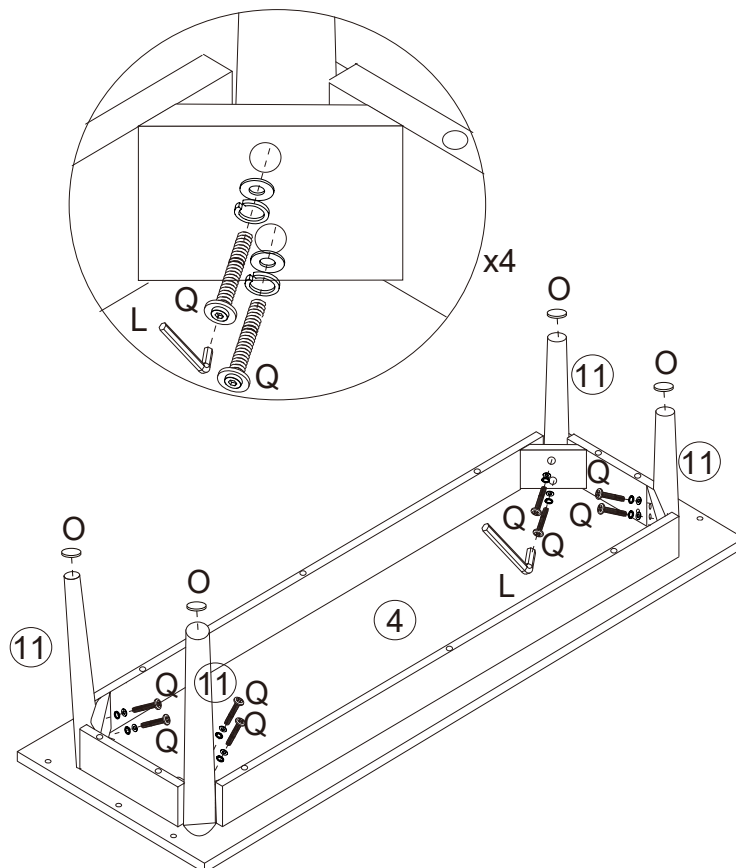

Step 9: Assemble the base with frame by hardware C,L,J;
DO NOT use any power tools as this may damage the frame and will invalidate any claim.

CX4
JX6
LX1

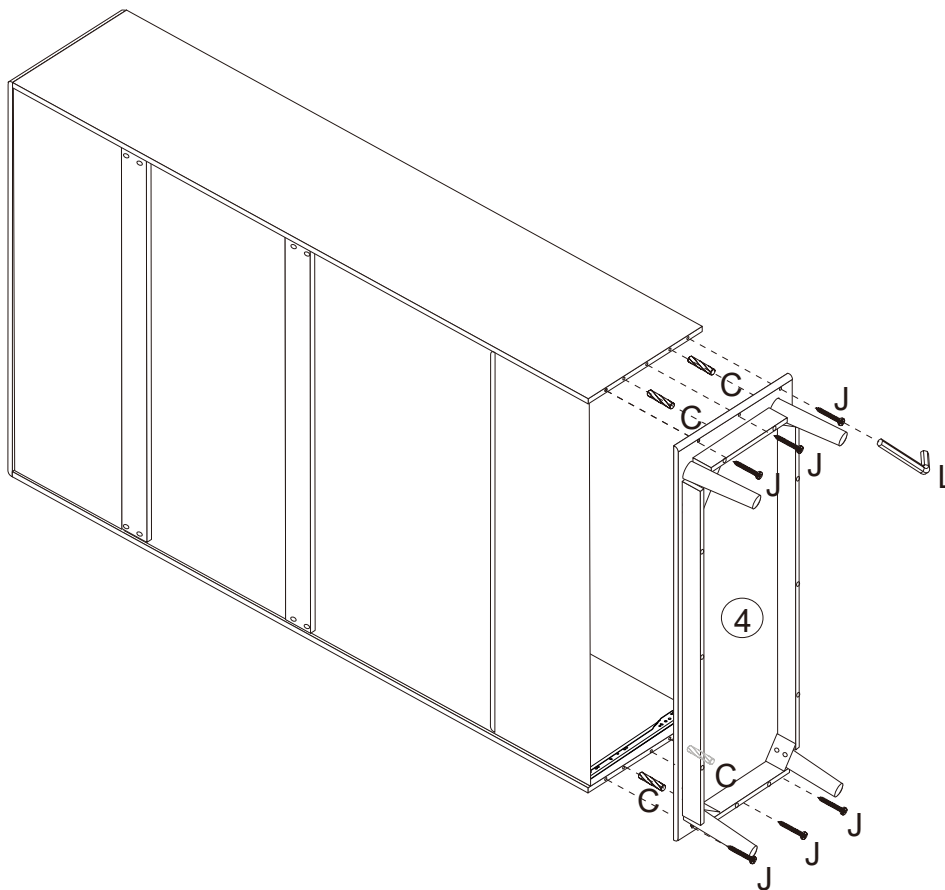

Step 10: Attach the hardware I.
DO NOT use any power tools as this may damage the frame and will invalidate any claim.

IX16

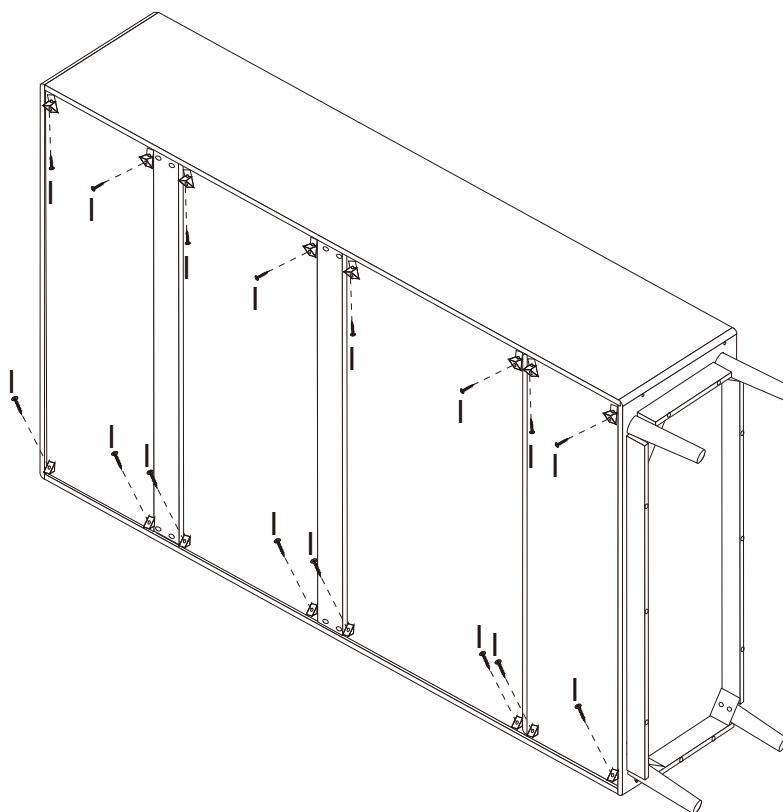

Step 11: Attach hardware T on door(12),(17) by hardware U; Then, attach the handle H and the hardware S.
DO NOT use any power tools as this may damage the frame and will invalidate any claim.

UX12
HX2
SX2
TX6

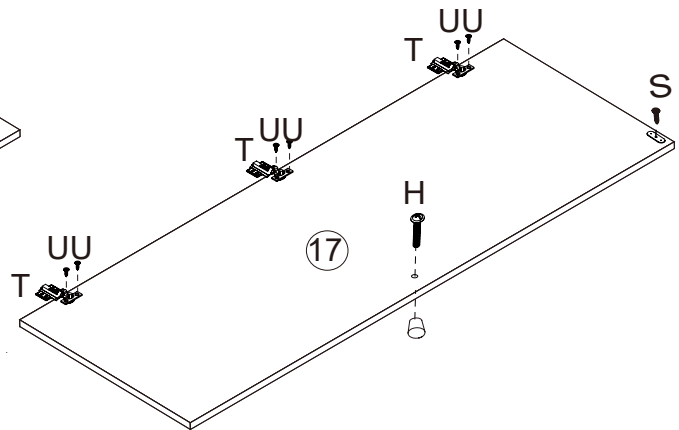
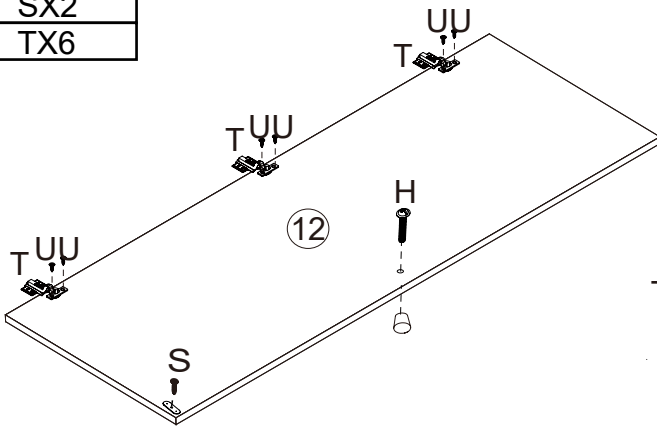

Step 12: Assemble the door(12),(17) with side panels(1),(2) by hardware U;
 Attach the hanging (18);

DO NOT use any power tools as this may damage the frame and will invalidate any claim.

UX24

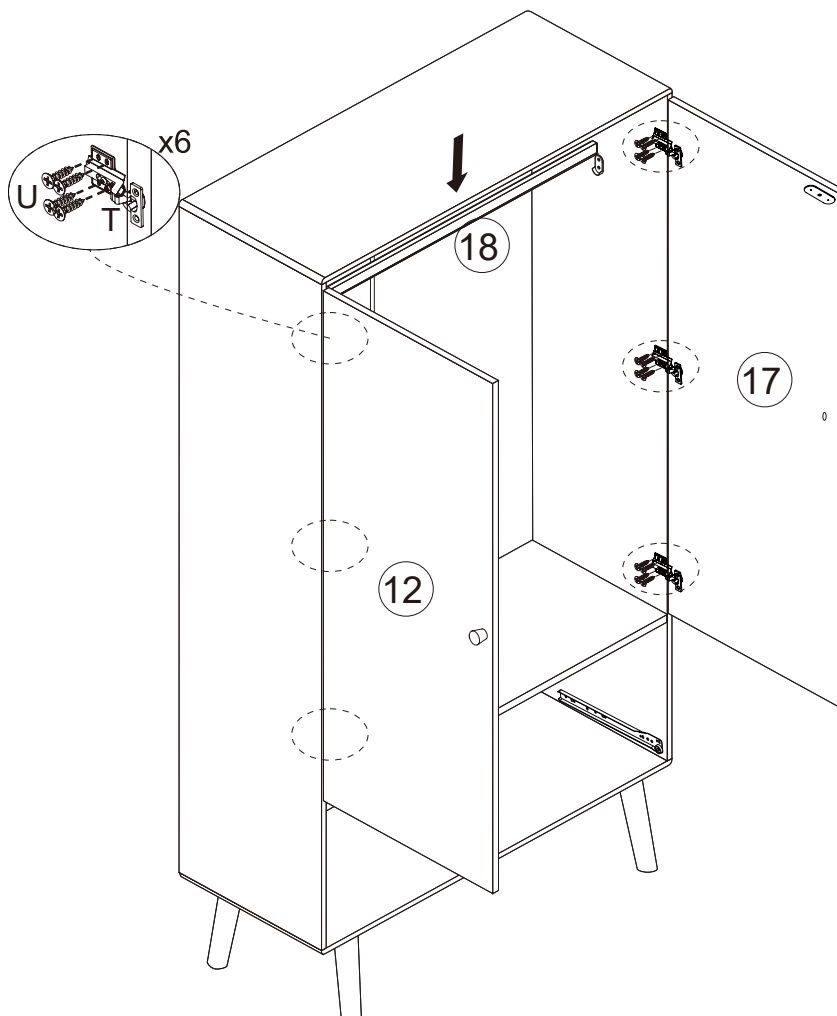

Step 13: Secure the safty strap(N) by hardware F,M.

DO NOT use any power tools as this may damage the frame and will invalidate any claim.

FX2
MX2
NX2

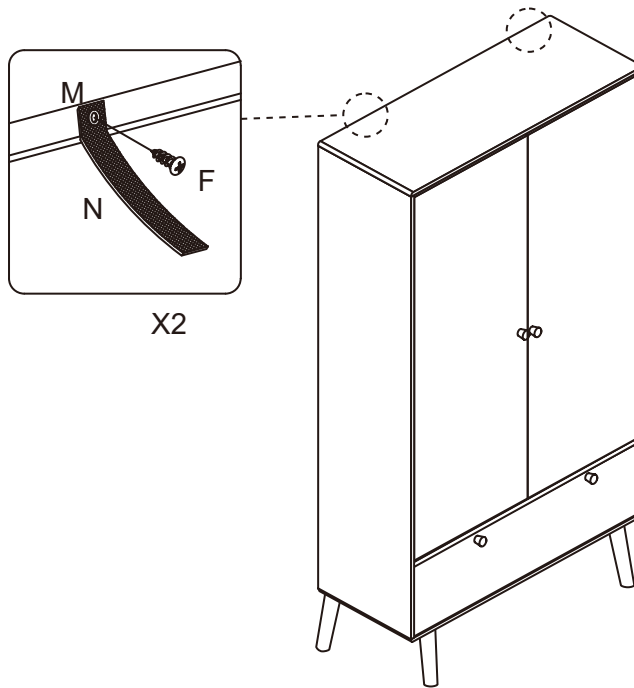

X2

PLEASE NOTE that wall fixings are not supplied as different wall materials require different fixing devices. You must use fixings devices suitable for the type of wall you intend to mount product to. Ensure the head of any screw used has a diameter greater than the mounting hole and the fixing is safe and secure before use.



WARNING!

In order to prevent overturning this product must be used with the wall attachment device provided. Serious or fatal crushing injuries can occur from furniture tipping over. To help prevent topple over:-

- Use the wall attachment devices provided
- Never allow children to climb or hang on drawers or doors
- Do not overload the drawer beyond maximum recommended loading
- Place heaviest items in the lower drawers or shelves
- Unless specifically designed to accommodate, do not set TV's or other heavy objects on top of this product
- Never open more than one drawer at a time
- Do not hang things from the doors

An attachment device is provided with your product, however you will need to source suitable fixings for your wall type. If in doubt consult a qualified trades person.

Always ensure that the wall to be drilled into is free from hidden electrical wire, water and gas pipe.

Birlea Furniture advise that the wall straps provided should be used to further enhance the safety of this product.

Additional Information:

- For complete product information, images and dimension diagrams please visit the website www.birlea.com
- If you have any issues with your item please contact the retailer directly you purchased it from who will be able to resolve any issues with Birlea.
- Why don't you send us photos of your assembled furniture to info@birlea.com to be shared in our #birleahome feature on instagram.