

56360

BARTON 3' BED WAXED PINE ASSEMBLY INSTRUCTIONS



**MAX BED
WEIGHT**



FOR DOMESTIC USE ONLY

IMPORTANT

PLEASE READ BEFORE YOU CONTINUE FURTHER

CARE AND MAINTENANCE

After unpacking this product please keep the original packaging in case it needs to be returned for any reason.

- Please ensure all fittings and parts are present before commencing with assembly.
- We recommend that you lay a blanket or sheet on the floor to avoid damage to both your floor and the product.
- We strongly recommend that you keep children away from your work area.
- Assemble this product as close to its final position as possible.
- Never drag or push products as this could cause damage to the joints making it inferior.
- Do not place this product next to a radiator or in direct sunlight.
- Wood is a natural product and may expand if subjected to damp and may shrink or crack if subjected to heat. Therefore it is recommended that room temperature is maintained, with no sudden temperature fluctuations.
- Make sure any spillage is wiped off immediately.
- Do not place hot or chilled items directly on to the surface, use a place mat or marking will occur.
- For general cleaning use a duster, and do not use detergents of any kind. However, the surface will need to be retreated from time to time. This can be done by using block wax (unperfumed) and rubbing it over the whole item.
- From time to time it may be necessary to tighten fittings, regular inspections should be carried out.

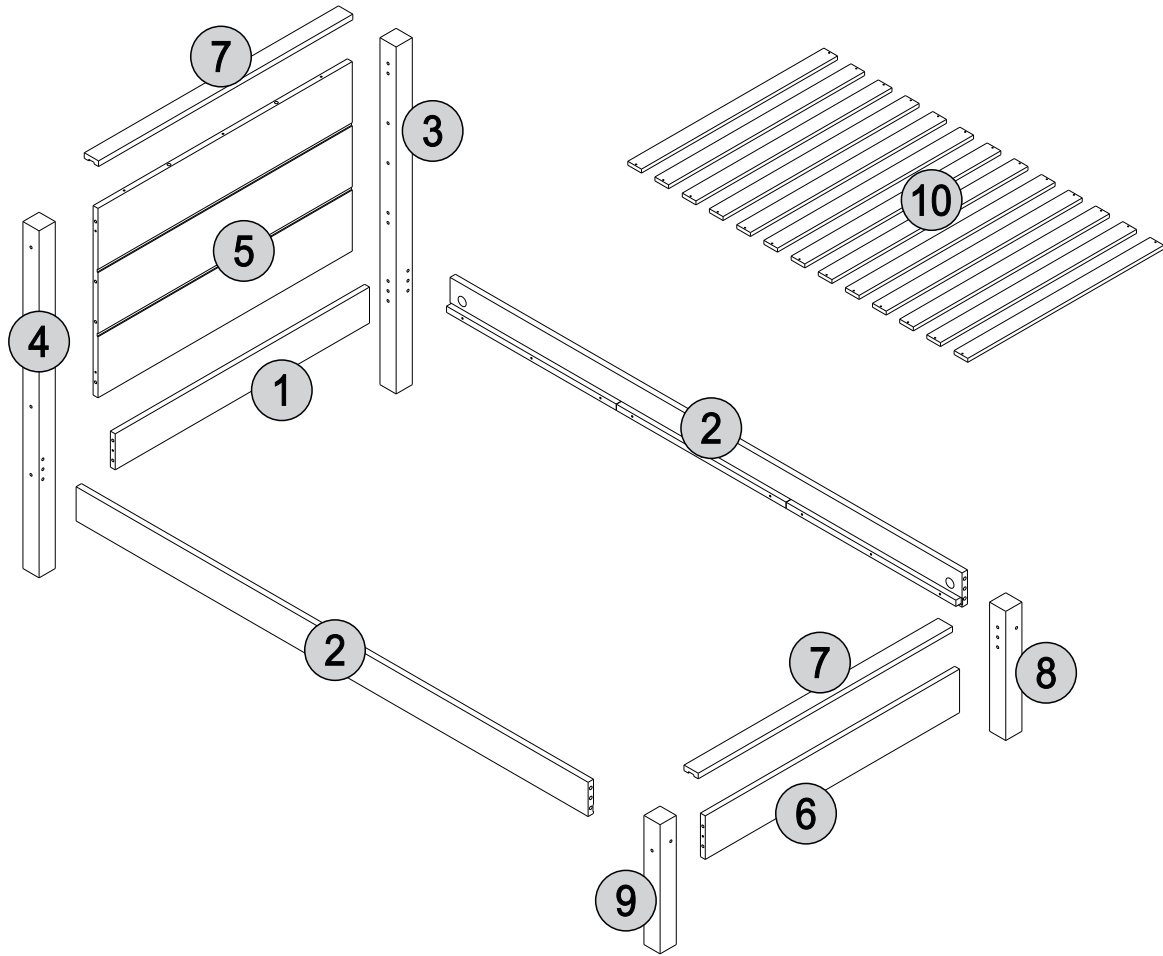







* Use of power tools to assemble this product will invalidate any claim and damage this product making it unsafe !!!
 * Please assemble on a clean soft surface to avoid damage.

* Please check contents and read the instructions before commencing assembly.
 * Assemble this product following the enclosed instructions carefully.
 * Please take care to avoid damaging panels during assembly.

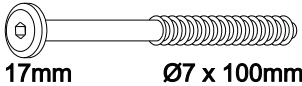
PARTS LIST

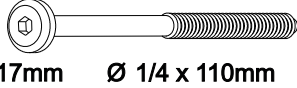
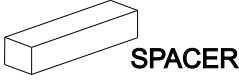
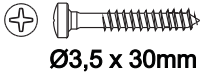
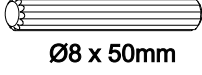
Part Number	Part Code	Part Description	Quantity	Carton
1	S200-201-075-PJ1-01	Headbord crossbeam	1	1/2
2	S200-201-075-PJ1-02	Siderail	2	2/2
3	S200-201-075-PJ1-03	Headboard Right Post	1	1/2
4	S200-201-075-PJ1-04	Headboard Left Post (Blue)	1	1/2
5	S200-201-075-PJ1-05	Headboard Panel	1	1/2
6	S200-201-075-PJ1-06	Footboard Panel	1	1/2
7	S200-201-075-PJ1-07	Top crossbeam	2	1/2
8	S200-201-075-PJ1-08	Footboard Right Post	1	1/2
9	S200-201-075-PJ1-09	Footboard Left Post (Blue)	1	1/2
10	S200-201-075-PJ1-10	Slats	13	1/2

FITTINGS

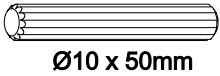
A	 17mm Ø7 x 100mm	08	G		01
B	 17mm Ø 1/4 x 110mm	04	H	 SPACER	02
C	 Ø3,5 x 30mm	06	I	 Ø8 x 50mm	16
D	 Ø4,0 x 30mm	26	J	 GLUE	01
E	 1/4	04	K	 Ø8 x 30mm	04
F	 Ø10 x 50mm	08			

TOOLS REQUIRED

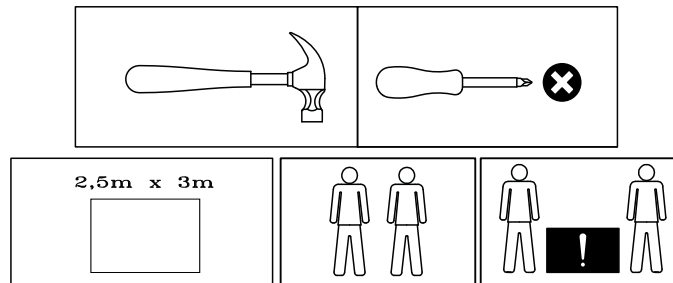

STEP 1

PARTS REQUIRED

1 - HEADBOARD CROSSBEAM x1

6 - FOOTBOARD PANEL x1

HARDWARE REQUIRED

I  08
Ø8 x 50mm

J  01
GLUE

TOOLS REQUIRED

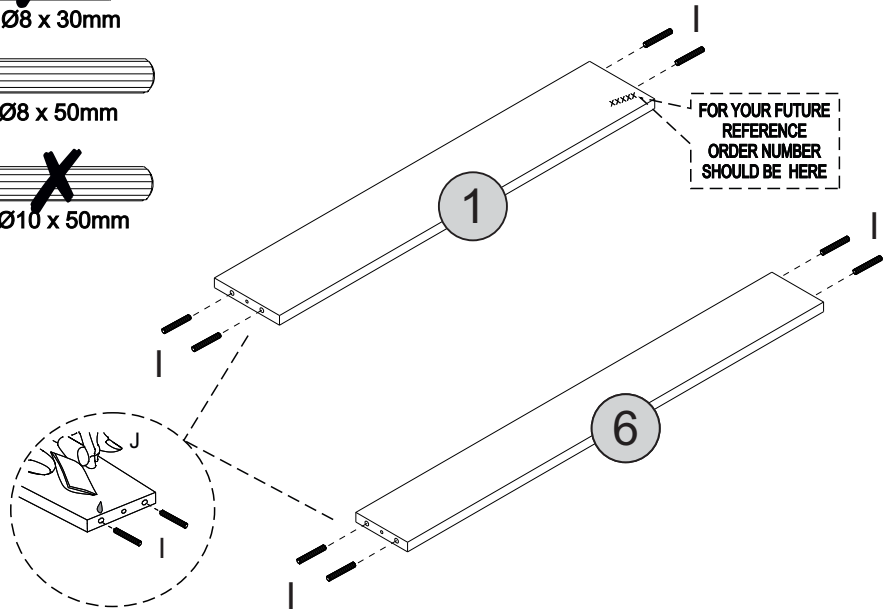
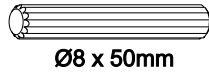

Please assemble on
a clean soft surface
to avoid damage.

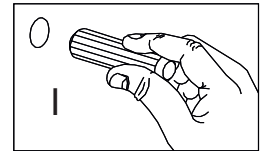

STEP 2

PARTS REQUIRED

2 - SIDERAIL x2

HARDWARE REQUIRED

F  08
Ø10x50mm

J  01
GLUE

TOOLS REQUIRED

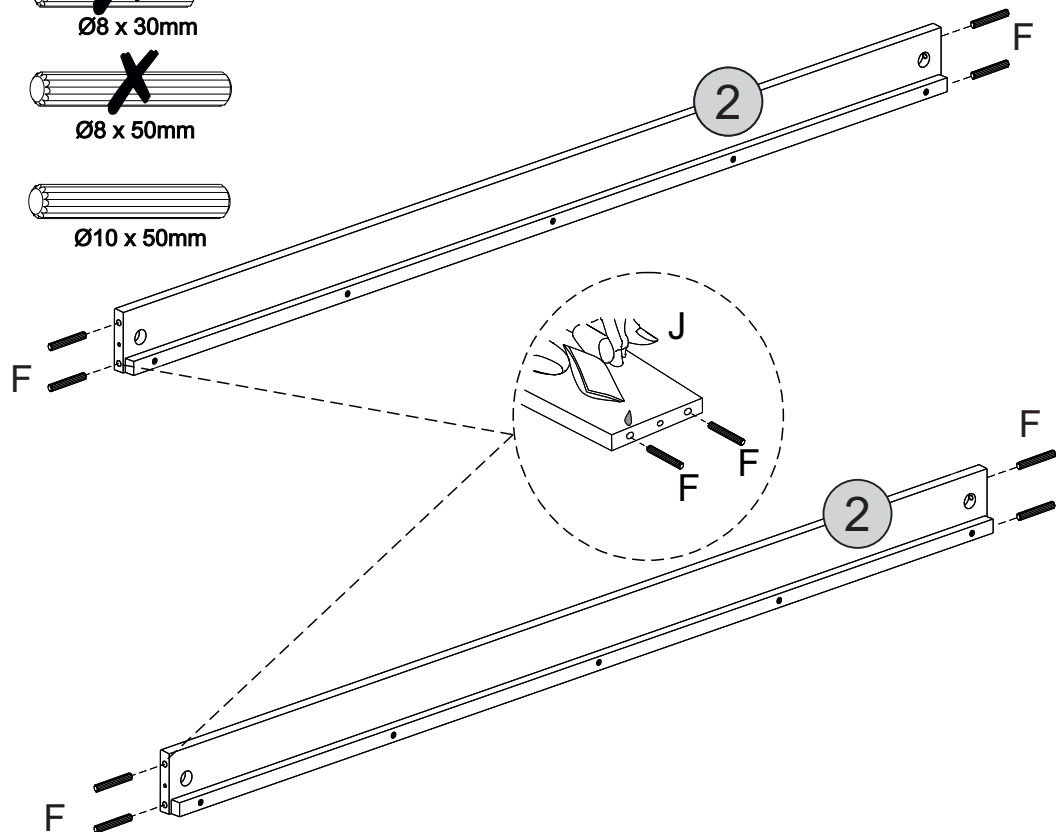
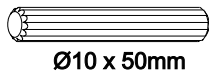



STEP 3

PARTS REQUIRED

5 - HEADBOARD PANEL x1

HARDWARE REQUIRED

- I  08
Ø8 x 50mm
- J  01
GLUE
- K  02
Ø8 x 30mm

TOOLS REQUIRED

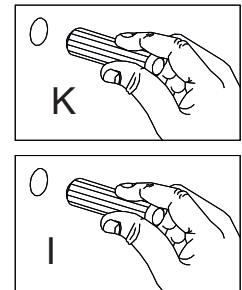
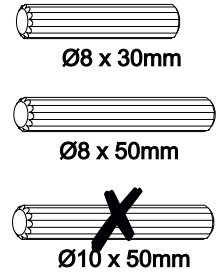
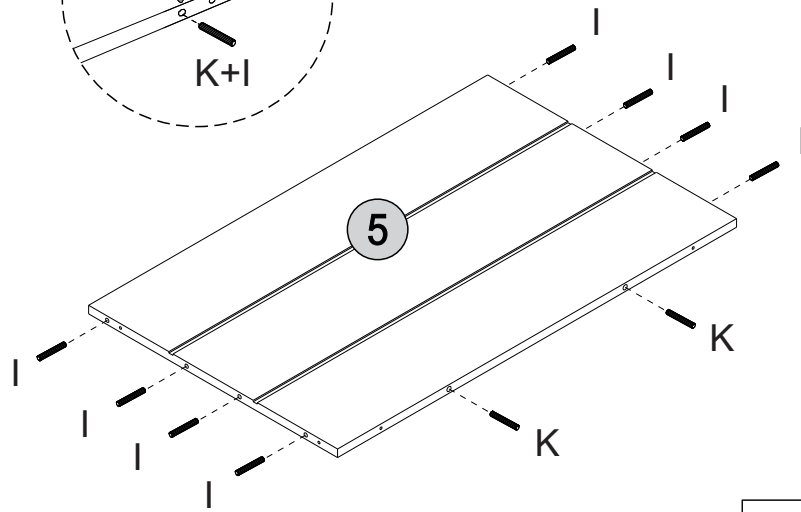
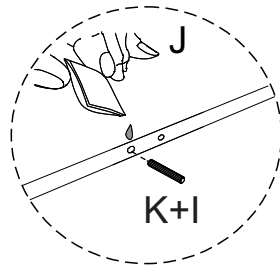

!
Please assemble on a clean soft surface to avoid damage.

STEP 4

PARTS REQUIRED

- 1 - HEADBOARD CROSSBEAM x1
- 3 - HEADBOARD RIGHT POST x1
- 4 - HEADBOARD LEFT POST (BLUE) x1
- 5 - HEADBOARD PANEL x1

HARDWARE REQUIRED

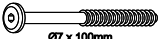
- A  06
Ø7 x 100mm

TOOLS REQUIRED

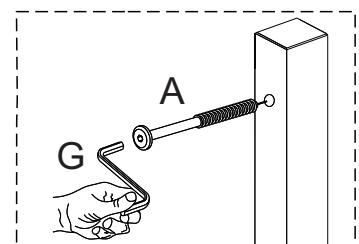
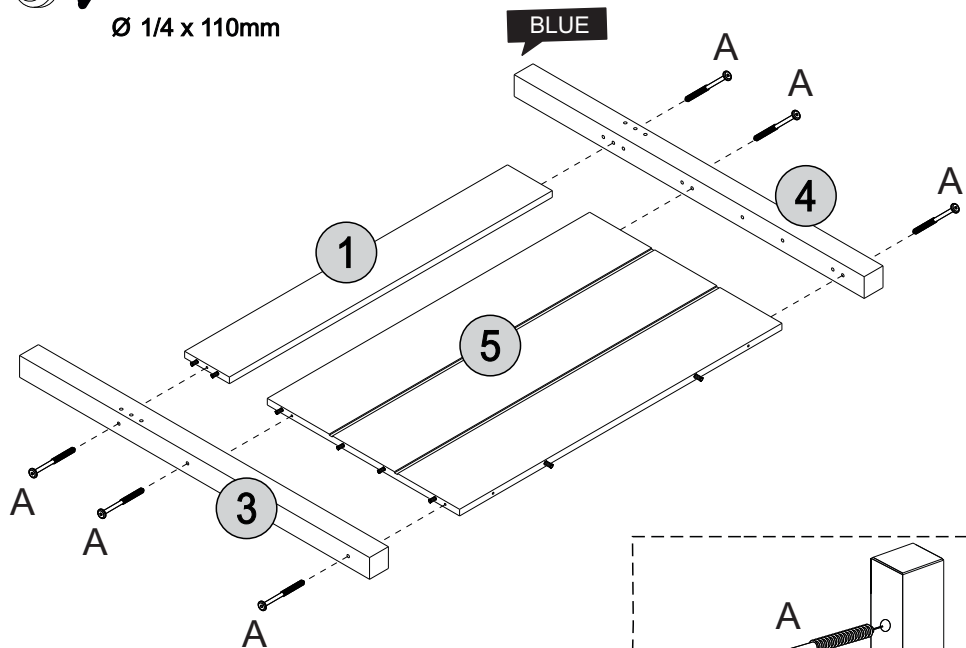
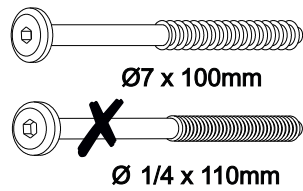
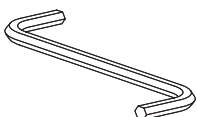

!
Please assemble on a clean soft surface to avoid damage.

STEP 5

PARTS REQUIRED

7 - TOP CROSSBEAM x1

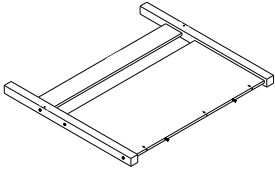

HARDWARE REQUIRED

C  Ø3,5 x 30mm 03

TOOLS REQUIRED

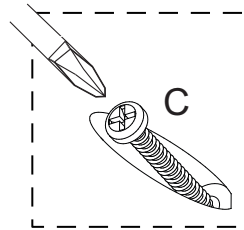
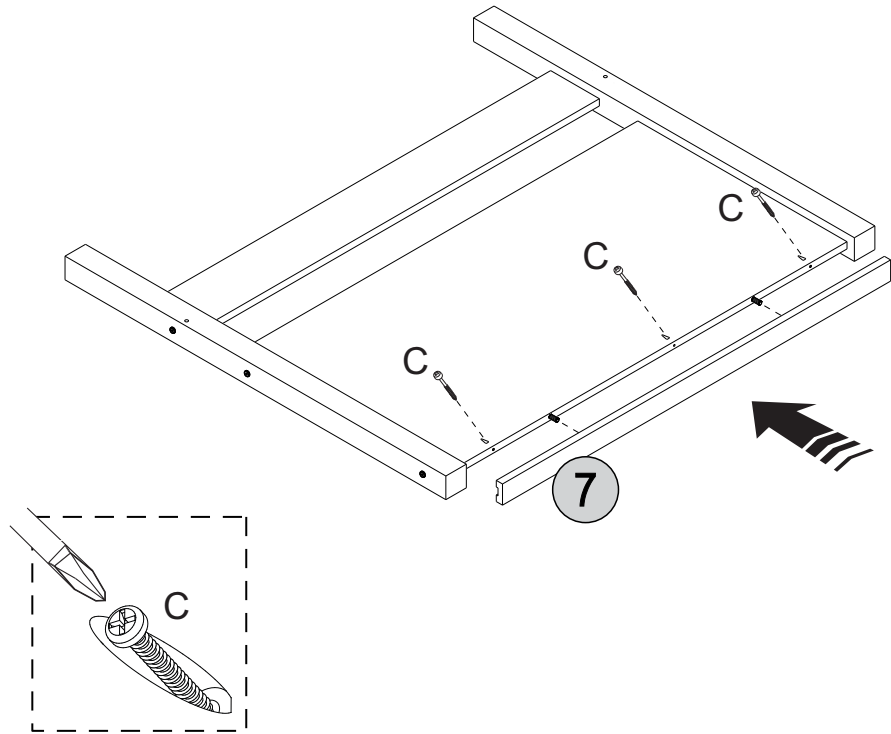
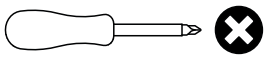

STEP 6

PARTS REQUIRED

6 - FOOTBOARD PANEL x1

8 - FOOTBOARD RIGHT POST x1

9 - FOOTBOARD LEFT POST (BLUE) x1

HARDWARE REQUIRED

A  Ø7 x 100mm 02

K  Ø8 x 30mm 02

TOOLS REQUIRED

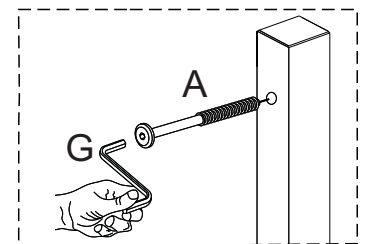
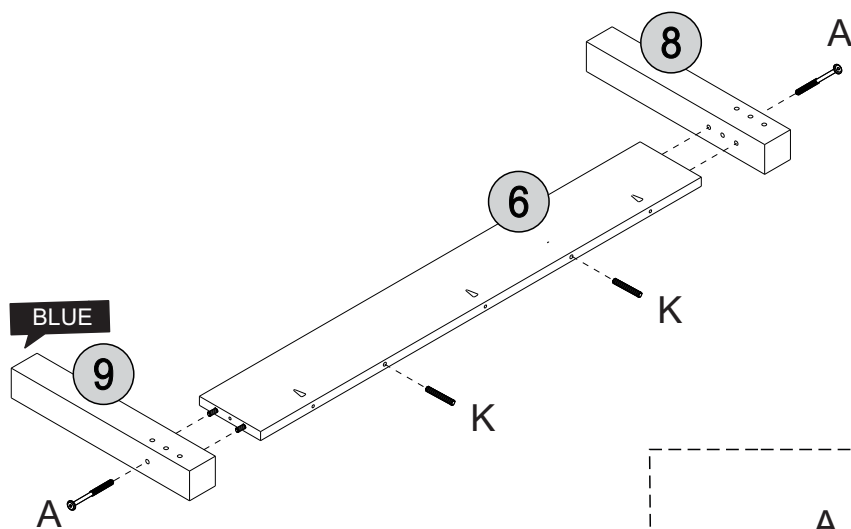
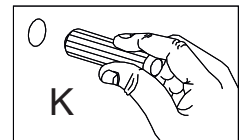
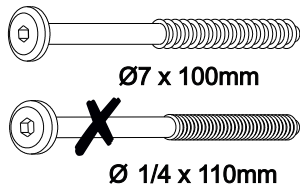
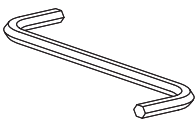

 Please assemble on a clean soft surface to avoid damage.

STEP 7

PARTS REQUIRED

7 - TOP CROSSBEAM x1

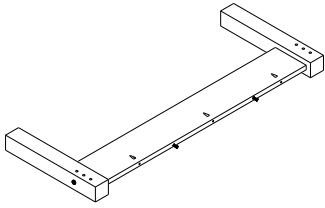

HARDWARE REQUIRED

C 03
Ø3,5 x 30mm

TOOLS REQUIRED

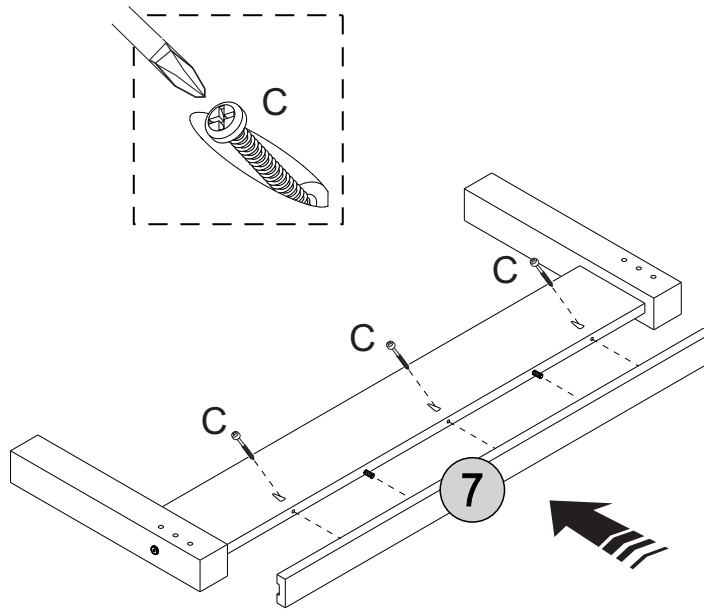
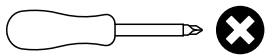

STEP 9

PARTS REQUIRED

2 - SIDERAIL x2

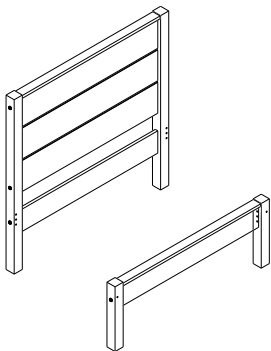

HARDWARE REQUIRED

B 04
Ø1/4 x 110mm

E 04
1/4

TOOLS REQUIRED

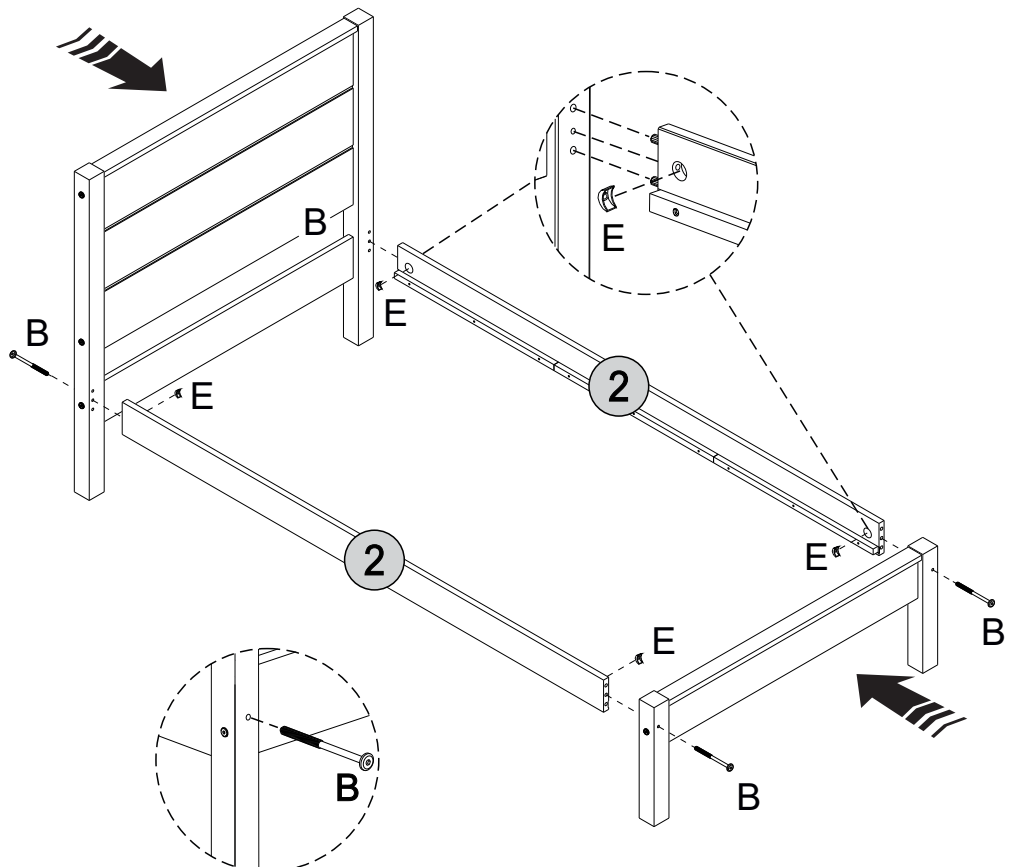
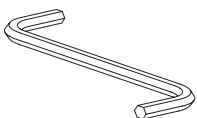

STEP 12

PARTS REQUIRED

10 - SLATS x13

HARDWARE REQUIRED

D  26
Ø4,0 x 30mm

H  02
SPACER

TOOLS REQUIRED

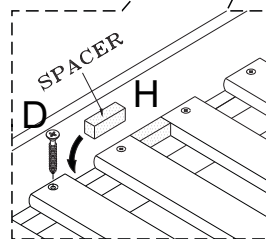
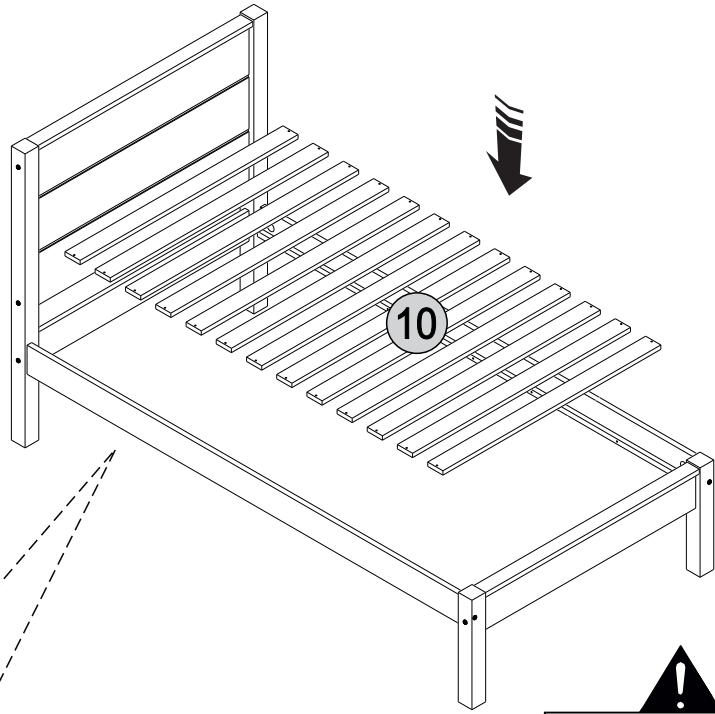
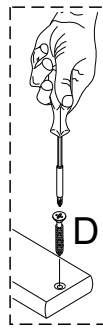
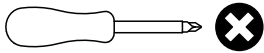

!
Please fix the first slats adjacent to the headboard and footboard and work towards the middle of the bed using the spacer (H) as shown to ensure correct spacing. Fix all the slats to one siderail first then push the second siderail tight against the slats and fix.

STEP 13

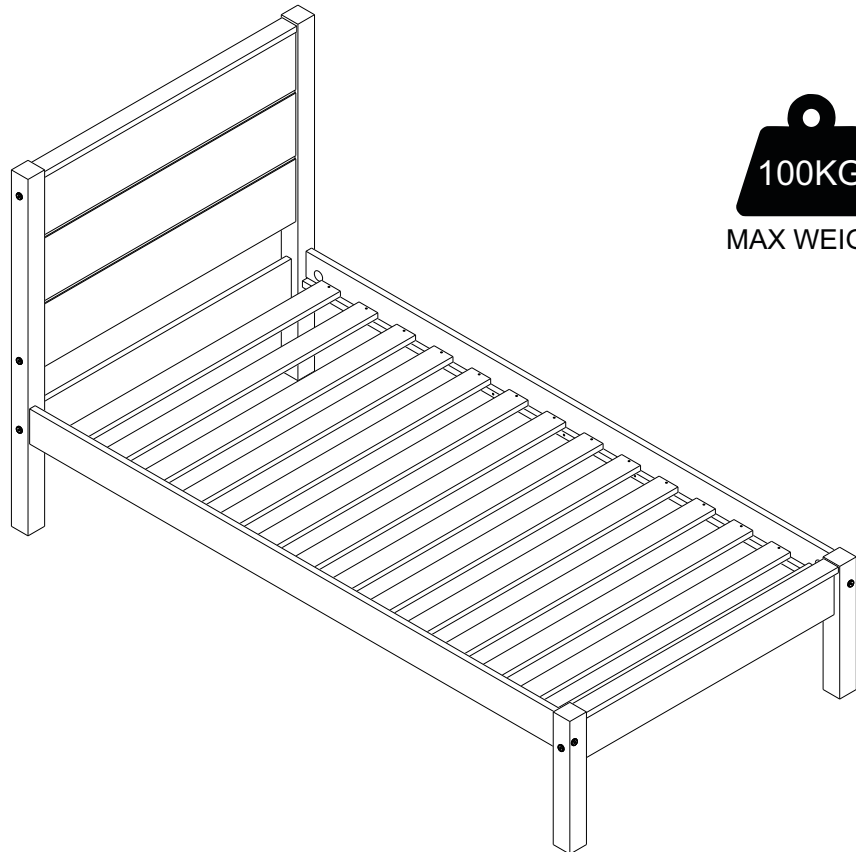

100KG
MAX WEIGHT