

AUSTIN DINING TABLE ASSEMBLY INSTRUCTIONS

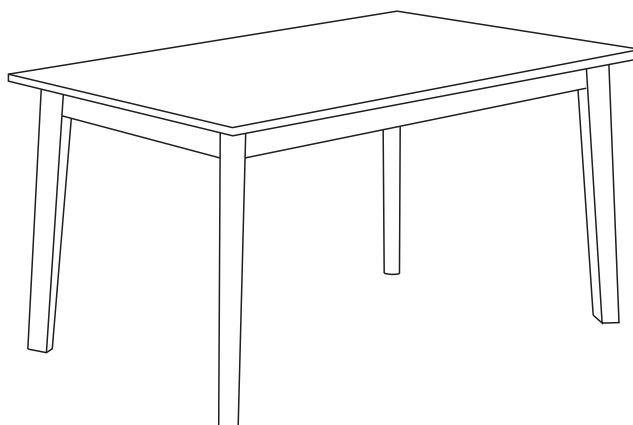

IMPORTANT

FOR DOMESTIC USE ONLY

PLEASE READ BEFORE YOU CONTINUE FURTHER

THE PRODUCT YOU HAVE PURCHASED WILL GIVE YOU MANY YEARS OF SERVICE IF YOU FOLLOW THE GUIDELINES FOR ITS SAFE ASSEMBLY AND PERIODIC MAINTENANCE AND CLEANING.

ASSEMBLE ON A SOFT CLEAN SURFACE.

DO NOT USE ANY TOOLS OTHER THAN THOSE SHOWN.

ANY SPANNERS OR ALLEN KEYS REQUIRED ARE INCLUDED WITH THE FITTINGS KIT.

DO NOT FOR ANY REASON USE A POWER TOOL TO ASSEMBLE THIS PRODUCT. ITS USE WILL INVALIDATE ANY CLAIM YOU MAY HAVE AND COULD MAKE THIS PRODUCT UNSAFE.

DEPENDING ON THE AMOUNT OF USE THIS PRODUCT RECEIVES IT MAY BE NECESSARY TO TIGHTEN UP THE FIXINGS FROM TIME TO TIME.

THIS IS COMPLETELY NORMAL FOR ANY FLAT PACK FURNITURE.

DO NOT OVERTIGHTEN FIXINGS.

FOR CLEANING, YOU MAY USE A DAMP CLOTH (NOT WET). DO NOT USE POLISH, DETERGENT OR CHEMICAL CLEANERS.

THE SURFACE OF THIS ITEM IS NOT HEAT RESISTANT. ALWAYS USE A PLACE MAT UNDER HOT OR COLD ITEMS TO PREVENT MARKING.



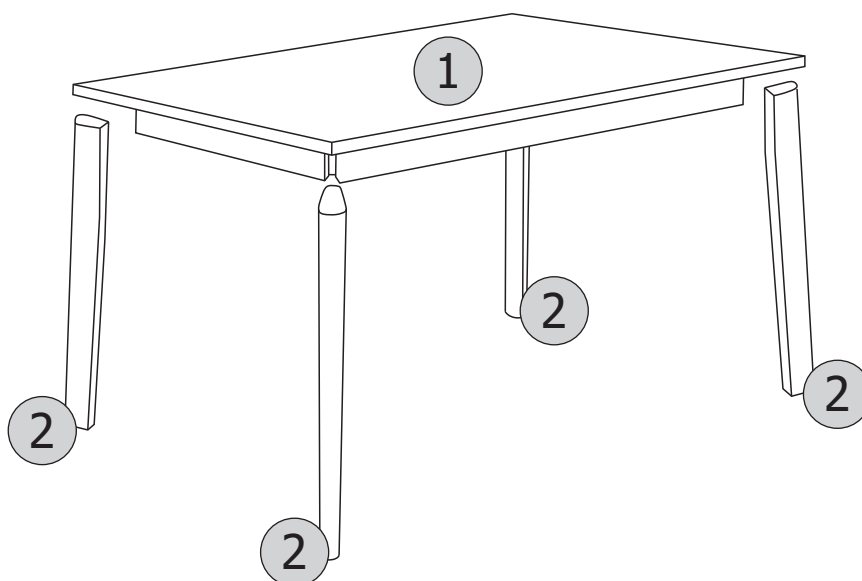

Please check that you have all the parts listed before you start assembling. If you do find that something is missing, do not continue assembly. Please contact your supplier immediately.



PART LIST

| Part Number | Part Code | Part Description | Quantity | Carton |
|--------------------|----------------------|-------------------------|-----------------|---------------|
| 1 | S400-403-068-PU1-01T | Table Top | 1 | 1/1 |
| 2 | S400-403-068-PU1-02T | Table Legs | 4 | 1/1 |

HARDWARE LIST

| No. | Part Name | | Qty | Carton |
|------------|-------------------------|---|------------|---------------|
| A | M6 x 60mm JCBC |  | 8 | 1 |
| B | Spring Washer M6 x 13mm |  | 8 | 1 |
| C | Flat Washer M6 x 18mm |  | 8 | 1 |
| D | Allen Key M4 x 65mm |  | 1 | 1 |

STEP 1

PARTS REQUIRED

1 - TABLE TOP x1

2 - TABLE LEGS x4

HARDWARE REQUIRED

A  08

B  08

C  08

TOOLS REQUIRED



REPEAT THIS ASSEMBLY FOR EACH LEG

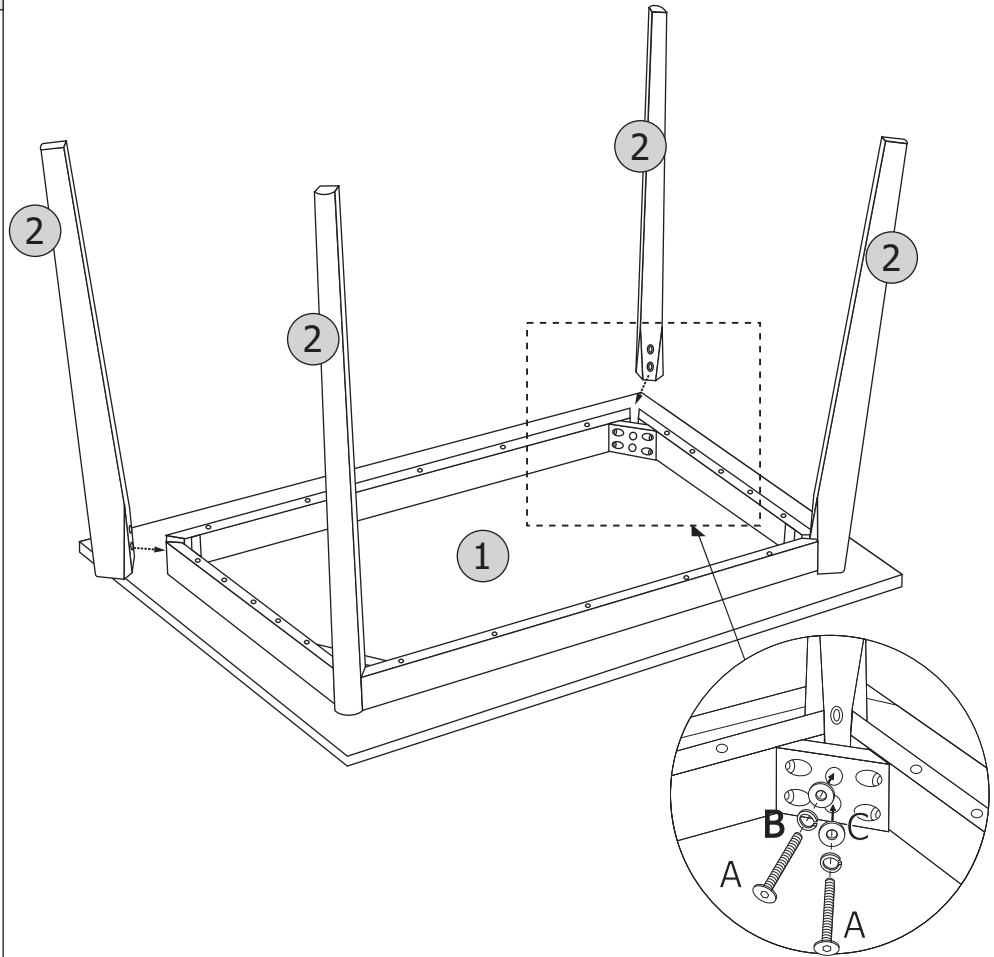

STEP 2

PARTS REQUIRED

HARDWARE REQUIRED

TOOLS REQUIRED

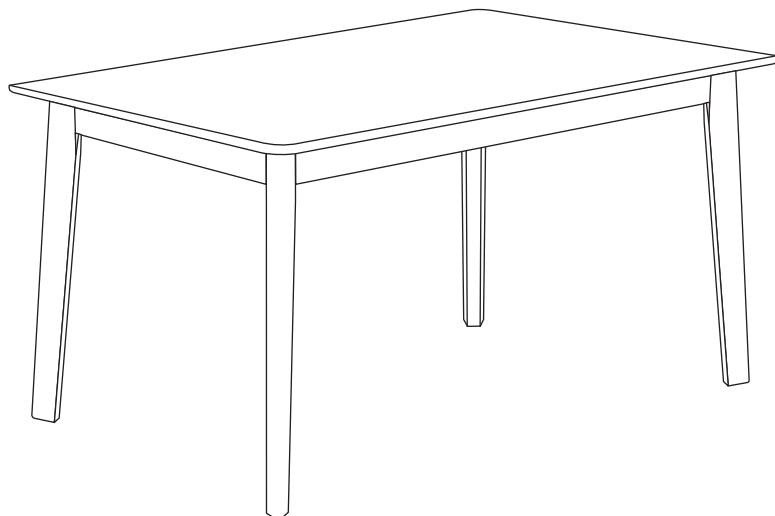

ELLIS DINING CHAIR ASSEMBLY INSTRUCTIONS

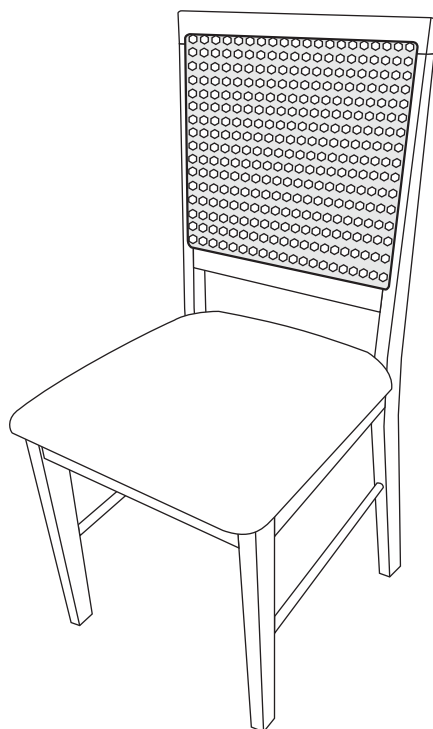

IMPORTANT

FOR DOMESTIC USE ONLY

PLEASE READ BEFORE YOU CONTINUE FURTHER

THE PRODUCT YOU HAVE PURCHASED WILL GIVE YOU MANY YEARS OF SERVICE IF YOU FOLLOW THE GUIDELINES FOR ITS SAFE ASSEMBLY AND PERIODIC MAINTENANCE AND CLEANING.

ASSEMBLE ON A SOFT CLEAN SURFACE.

DO NOT USE ANY TOOLS OTHER THAN THOSE SHOWN.

ANY SPANNERS OR ALLEN KEYS REQUIRED ARE INCLUDED WITH THE FITTINGS KIT.

DO NOT FOR ANY REASON USE A POWER TOOL TO ASSEMBLE THIS PRODUCT. ITS USE WILL INVALIDATE ANY CLAIM YOU MAY HAVE AND COULD MAKE THIS PRODUCT UNSAFE.

DEPENDING ON THE AMOUNT OF USE THIS PRODUCT RECEIVES IT MAY BE NECESSARY TO TIGHTEN UP THE FIXINGS FROM TIME TO TIME.

THIS IS COMPLETELY NORMAL FOR ANY FLAT PACK FURNITURE.

DO NOT OVERTIGHTEN FIXINGS.

FOR CLEANING, YOU MAY USE A DAMP CLOTH (NOT WET). DO NOT USE POLISH, DETERGENT OR CHEMICAL CLEANERS.

THE SURFACE OF THIS ITEM IS NOT HEAT RESISTANT. ALWAYS USE A PLACE MAT UNDER HOT OR COLD ITEMS TO PREVENT MARKING.

Please check that you have all the parts listed before you start assembling. If you do find that something is missing, do not continue assembly. Please contact your supplier immediately.



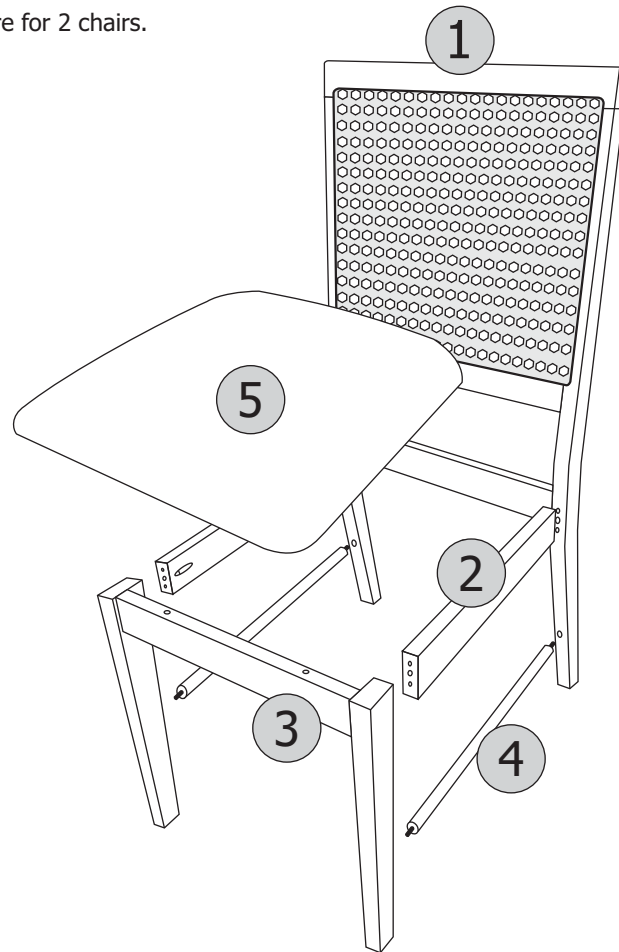



The parts and hardware below are for 2 chairs.



PART LIST

| Part Number | Part Code | Part Description | Quantity | Carton |
|-------------|----------------------|------------------|----------|--------|
| 1 | S400-402-143-PU1-01C | Chair Back | 2 | 1/1 |
| 2 | S400-402-143-PU1-02C | Side Stretcher | 4 | 1/1 |
| 3 | S400-402-143-PU1-03C | Front Section | 2 | 1/1 |
| 4 | S400-402-143-PU1-04C | Bottom Stretcher | 4 | 1/1 |
| 5 | S400-402-143-PU1-05C | Cushion Seat | 2 | 1/1 |

HARDWARE LIST

| No. | Part Name | | Qty | Carton |
|-----|-------------------------|---|-----|--------|
| A | M6 x 50mm JCBC |  | 12 | 1 |
| B | Spring Washer M6 x 13mm |  | 12 | 1 |
| C | Flat Washer M6 x 13mm |  | 12 | 1 |
| D | M4 x 32mm CSK Screw |  | 16 | 1 |
| E | Wood Dowel M8 x 30mm |  | 12 | 1 |
| F | Allen Key (Ball Head) |  | 1 | 1 |

STEP 1

PARTS REQUIRED

2 - SIDE STRETCHER x2

HARDWARE REQUIRED

E  06

TOOLS REQUIRED

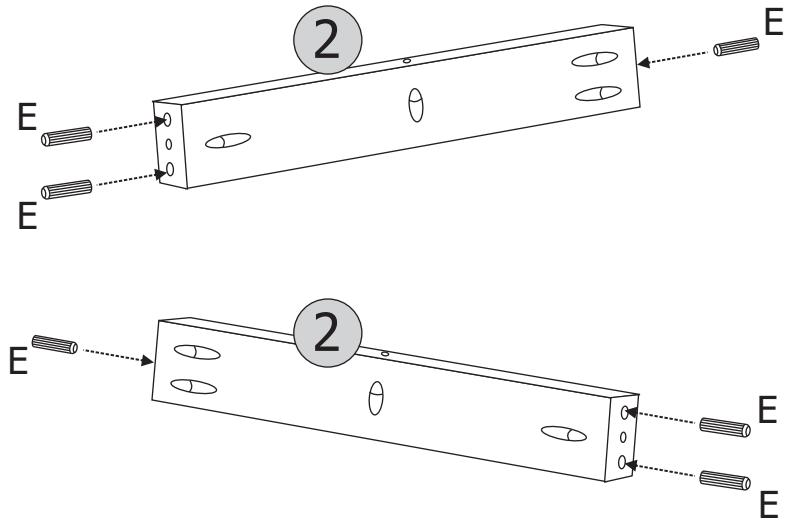
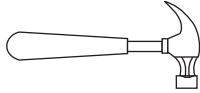

STEP 2

PARTS REQUIRED

1 - CHAIR BACK x1

2 - SIDE STRETCHER x2

4 - BOTTOM STRETCHER x2

HARDWARE REQUIRED

A  04

B  04

C  04

D  02

TOOLS REQUIRED

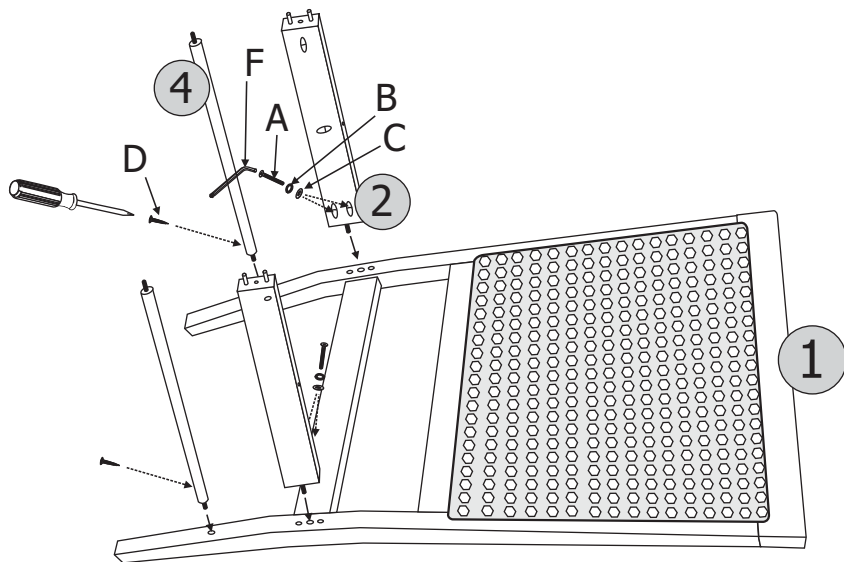
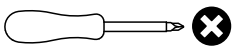





Important
Please **do not** fully tighten
the screws before **STEP 3 !!**

STEP 3

PARTS REQUIRED

3 - FRONT SECTION x1

HARDWARE REQUIRED

- A  02
- B  02
- C  02
- D  02

TOOLS REQUIRED

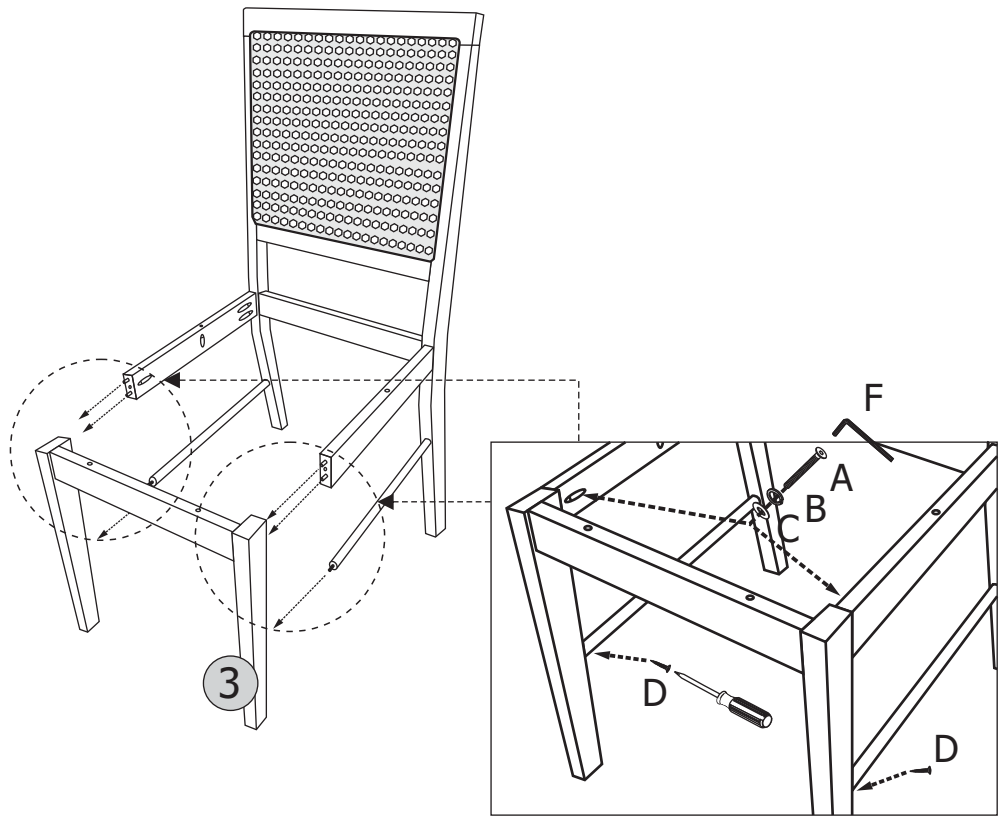
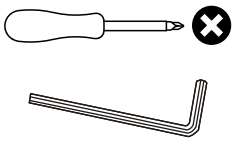

Important
Please now fully tighten **all** bolts.

STEP 4

PARTS REQUIRED

5 - CUSHION SEAT x1

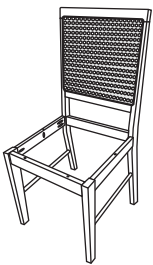

HARDWARE REQUIRED

- D  04

TOOLS REQUIRED

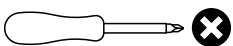

Bottom View

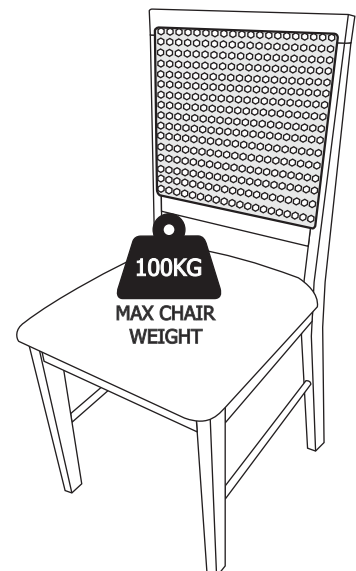
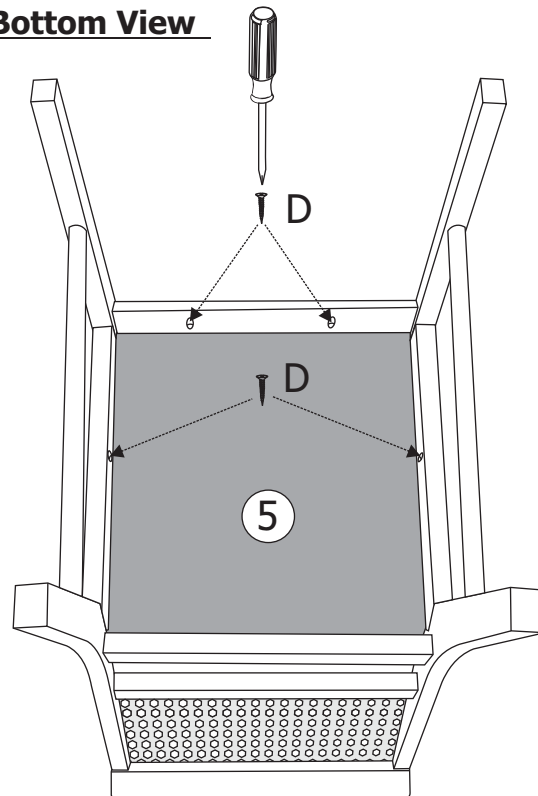

ELLIS DINING BENCH ASSEMBLY INSTRUCTIONS

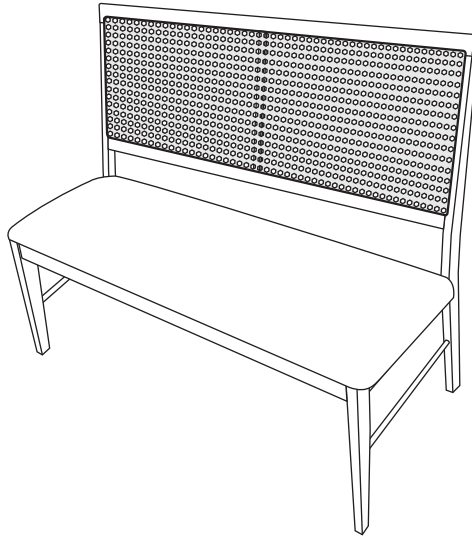

IMPORTANT **FOR DOMESTIC USE ONLY**

PLEASE READ BEFORE YOU CONTINUE FURTHER

THE PRODUCT YOU HAVE PURCHASED WILL GIVE YOU MANY YEARS OF SERVICE IF YOU FOLLOW THE GUIDELINES FOR ITS SAFE ASSEMBLY AND PERIODIC MAINTENANCE AND CLEANING.

ASSEMBLE ON A SOFT CLEAN SURFACE.

DO NOT USE ANY TOOLS OTHER THAN THOSE SHOWN.

ANY SPANNERS OR ALLEN KEYS REQUIRED ARE INCLUDED WITH THE FITTINGS KIT.

DO NOT FOR ANY REASON USE A POWER TOOL TO ASSEMBLE THIS PRODUCT. ITS USE WILL INVALIDATE ANY CLAIM YOU MAY HAVE AND COULD MAKE THIS PRODUCT UNSAFE.

DEPENDING ON THE AMOUNT OF USE THIS PRODUCT RECEIVES IT MAY BE NECESSARY TO TIGHTEN UP THE FIXINGS FROM TIME TO TIME. THIS IS COMPLETELY NORMAL FOR ANY FLAT PACK FURNITURE.

DO NOT OVERTIGHTEN FIXINGS.

FOR CLEANING, YOU MAY USE A DAMP CLOTH (NOT WET). DO NOT USE POLISH, DETERGENT OR CHEMICAL CLEANERS.

THE SURFACE OF THIS ITEM IS NOT HEAT RESISTANT. ALWAYS USE A PLACE MAT UNDER HOT OR COLD ITEMS TO PREVENT MARKING.



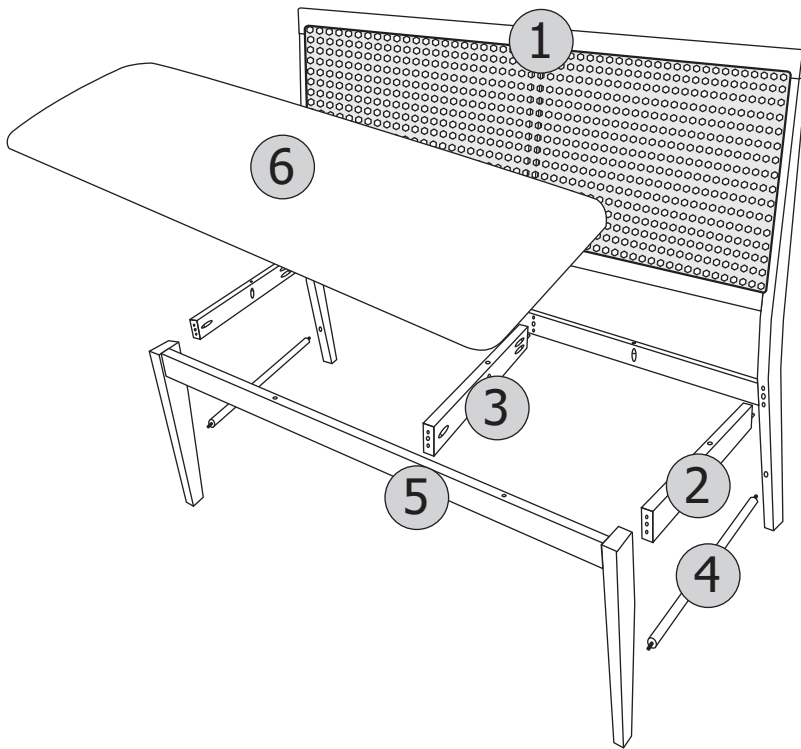



Please check that you have all the parts listed before you start assembling. If you do find that something is missing, do not continue assembly. Please contact your supplier immediately.



PART LIST

| <u>Part Number</u> | <u>Part Code</u> | <u>Part Description</u> | <u>Quantity</u> | <u>Carton</u> |
|--------------------|----------------------|-------------------------|-----------------|---------------|
| 1 | S400-420-010-PU1-01B | Chair Back | 1 | 1/1 |
| 2 | S400-420-010-PU1-02B | Side Stretcher | 2 | 1/1 |
| 3 | S400-420-010-PU1-03B | Center Stretcher | 1 | 1/1 |
| 4 | S400-420-010-PU1-04B | Bottom Stretcher | 2 | 1/1 |
| 5 | S400-420-010-PU1-05B | Front Section | 1 | 1/1 |
| 6 | S400-420-010-PU1-06B | Cushion Seat | 1 | 1/1 |

HARDWARE LIST

| <u>No.</u> | <u>Part Name</u> | | <u>Qty</u> | <u>Carton</u> |
|------------|--------------------------------|---|------------|---------------|
| A | M6 x 50mm JCBC |  | 9 | 1 |
| B | Spring Washer M6 x 13mm |  | 9 | 1 |
| C | Flat Washer M6 x 13mm |  | 9 | 1 |
| D | M4 x 32mm CSK Screw |  | 11 | 1 |
| E | Wood Dowel M8 x 30mm |  | 9 | 1 |
| F | Allen Key M4 x 107mm Ball Head |  | 1 | 1 |

STEP 1

PARTS REQUIRED

- 2. SIDE STRETCHER X2
- 3. CENTER STRETCHER X1

HARDWARE REQUIRED

- E  09

TOOLS REQUIRED

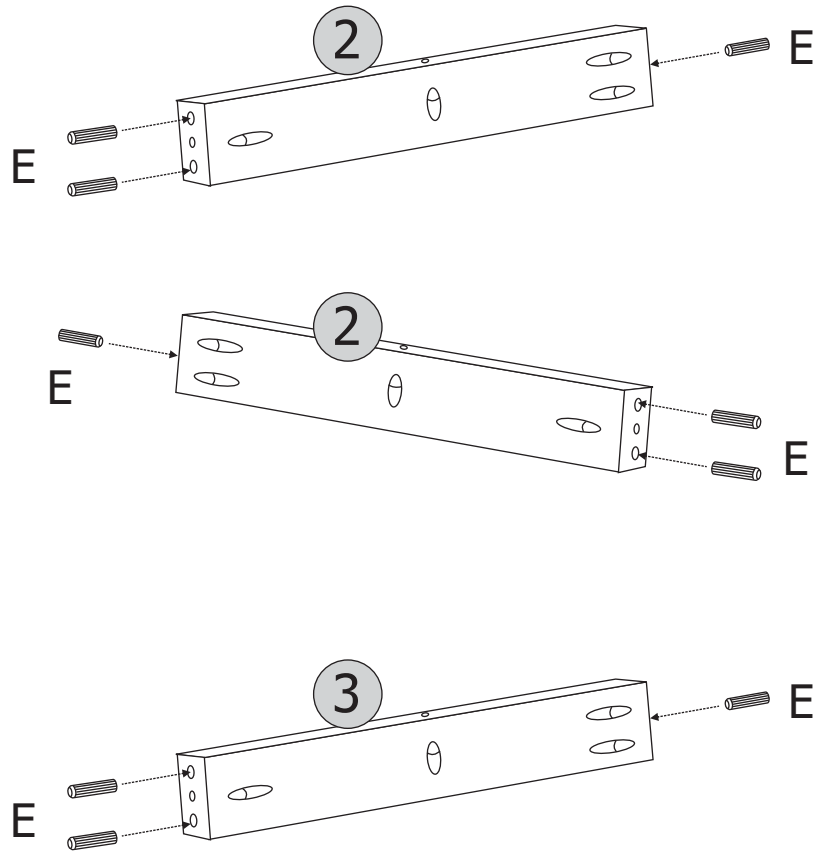
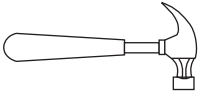





STEP 2

PARTS REQUIRED

- 1. CHAIR BACK X1
- 2. SIDE STRETCHER X2
- 3. CENTER STRETCHER X1
- 4. BOTTOM STRETCHER X2

HARDWARE REQUIRED

- A  06
- B  06
- C  06
- D  02

TOOLS REQUIRED

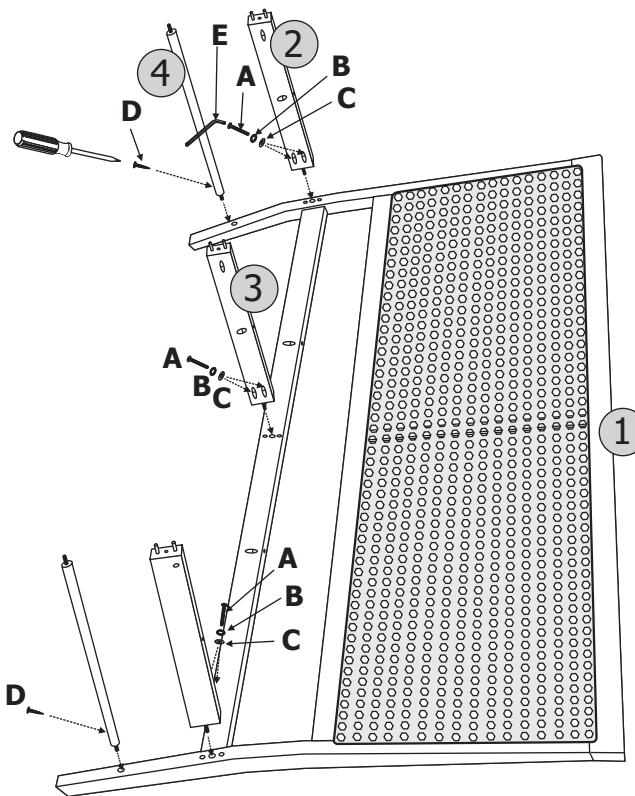
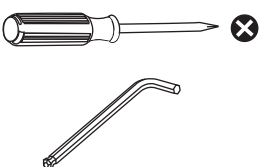

Important
Please **do not** fully tighten
the screws before **STEP 3!!**

STEP 3

PARTS REQUIRED

5. FRONT SECTION X1

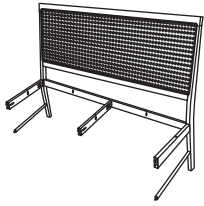

HARDWARE REQUIRED

A  03

B  03

C  03

D  02

TOOLS REQUIRED

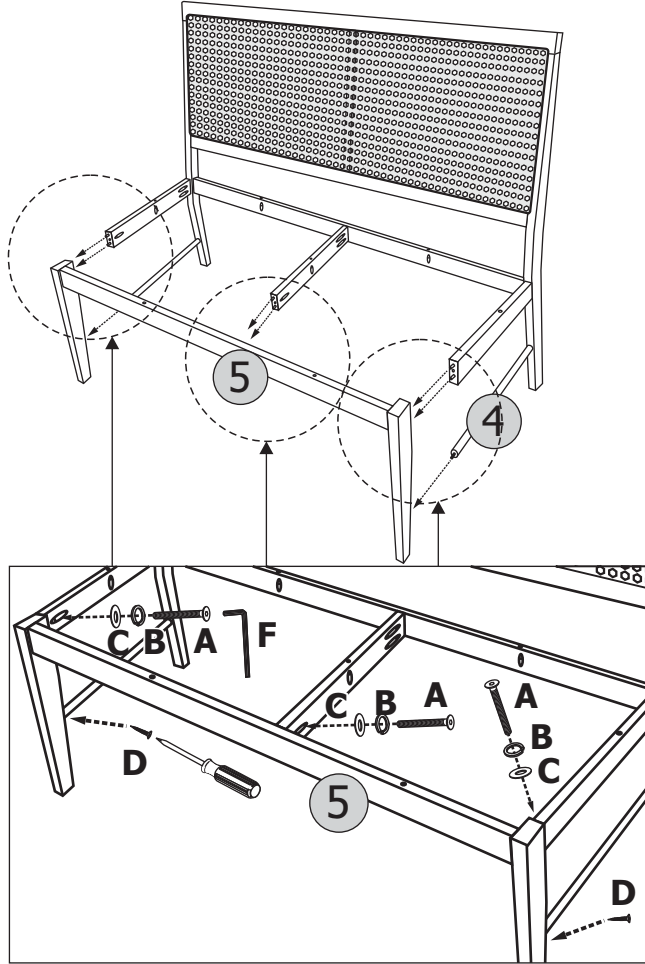
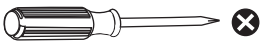

Important
Please now fully tighten
all bolts.

STEP 4

PARTS REQUIRED

6. CUSHION SEAT X1

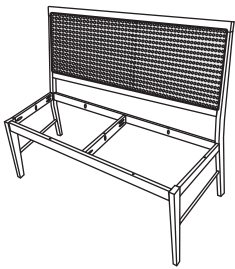

HARDWARE REQUIRED

D  07

TOOLS REQUIRED

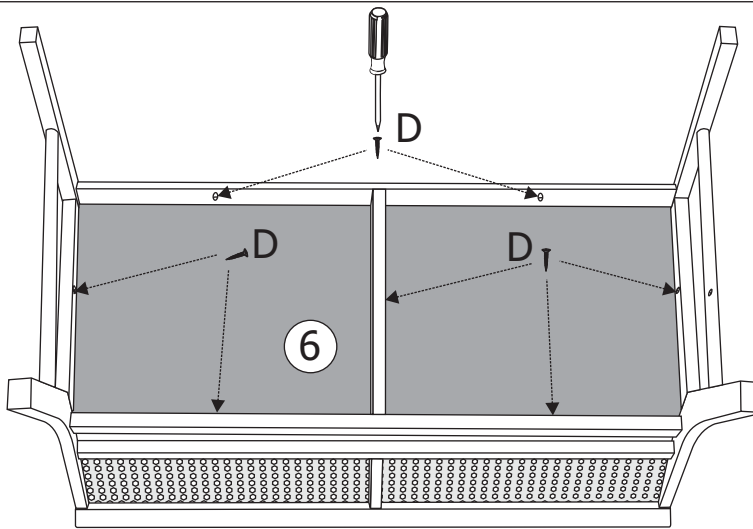
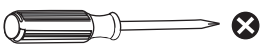

Bottom View

