

# LEON 2 DOOR 1 DRAWER WARDROBE ASSEMBLY INSTRUCTIONS

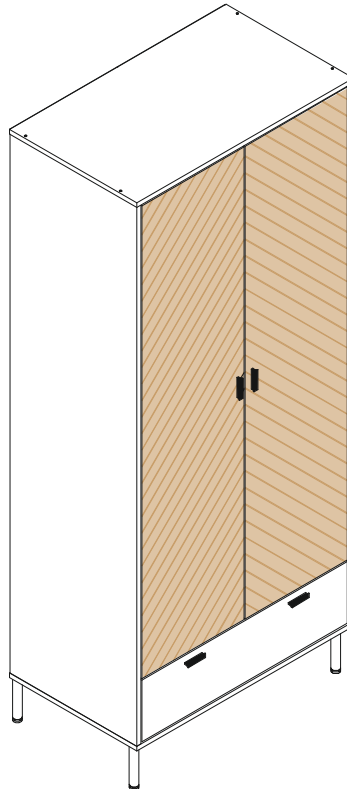

**FOR DOMESTIC USE ONLY  
IMPORTANT**

**PLEASE READ BEFORE YOU CONTINUE FURTHER**

THE PRODUCT YOU HAVE PURCHASED WILL GIVE YOU MANY YEARS OF SERVICE IF YOU FOLLOW THE GUIDELINES FOR ITS SAFE ASSEMBLY AND PERIODIC MAINTENANCE AND CLEANING.

ASSEMBLE ON A SOFT CLEAN SURFACE.

DO NOT USE ANY TOOLS OTHER THAN THOSE SHOWN.

ANY SPANNERS OR ALLEN KEYS REQUIRED ARE INCLUDED WITH THE FITTING KIT.

DO NOT FOR ANY REASON USE A POWER TOOL TO ASSEMBLE THIS PRODUCT. ITS USE WILL INVALIDATE ANY CLAIM YOU MAY HAVE AND COULD MAKE THIS PRODUCT UNSAFE.

DEPENDING ON THE AMOUNT OF USE THIS PRODUCT RECEIVES, IT MAY BE NECESSARY TO TIGHTEN UP THE FIXINGS FROM TIME TO TIME. THIS IS COMPLETELY NORMAL FOR ANY FLAT PACK FURNITURE. DO NOT OVERTIGHTEN FIXINGS.

FOR CLEANING, YOU MAY USE A DAMP CLOTH (NOT WET). DO NOT USE POLISH, DETERGENT OR CHEMICAL CLEANERS.



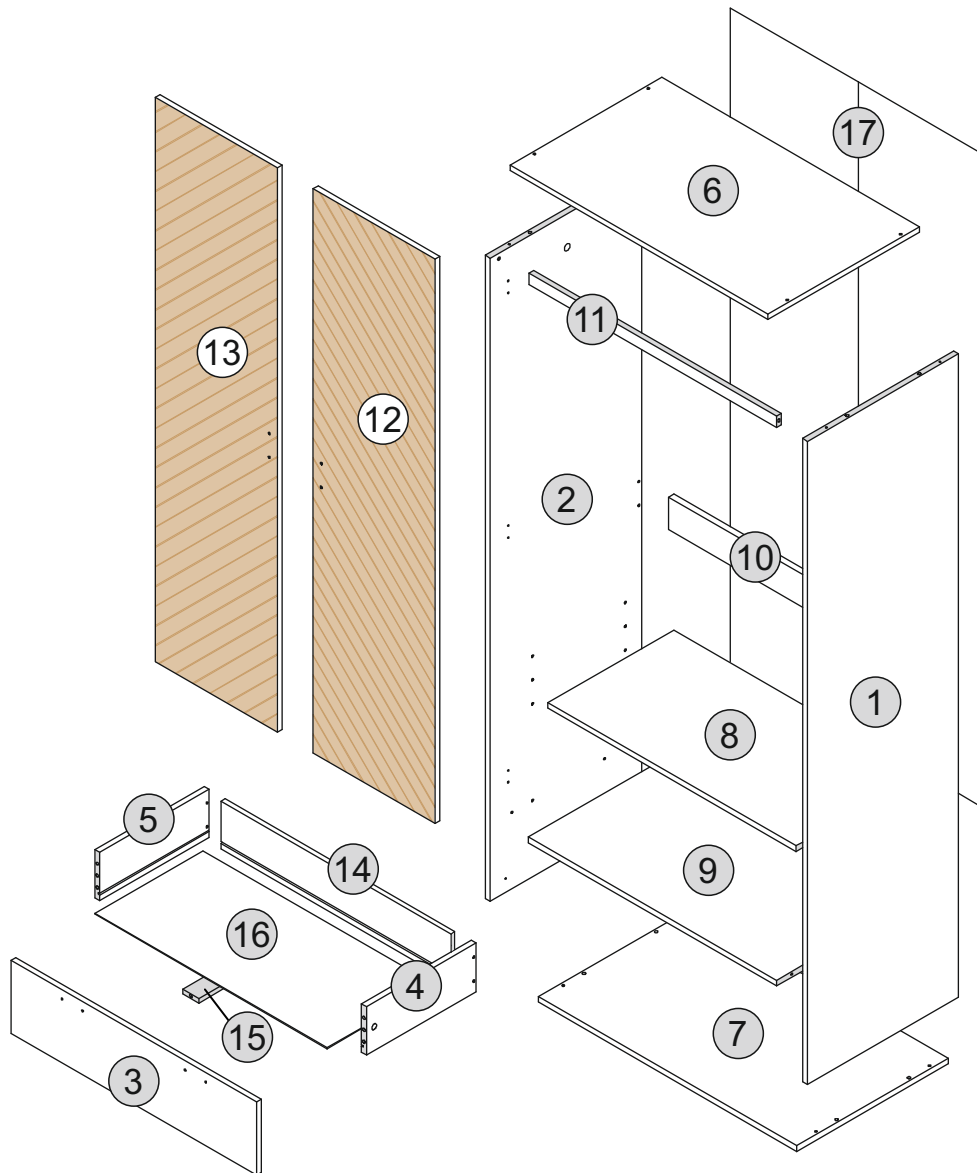













THIS SURFACE OF THIS ITEM IS NOT HEAT RESISTANT. ALWAYS USE A PLACE MAT UNDER HOT OR COLD ITEMS TO PREVENT MARKING.



## PART LIST

Part Number	Part Code	Part Description	Quantity	Carton
1	S100-101-199-ZF1-01	Right Side Panel	1	1/2
2	S100-101-199-ZF1-02	Left Side Panel	1	1/2
3	S100-101-199-ZF1-03	Drawer Front	1	2/2
4	S100-101-199-ZF1-04	Right Drawer Side Panel	1	2/2
5	S100-101-199-ZF1-05	Left Drawer Side Panel	1	2/2
6	S100-101-199-ZF1-06	Top Panel	1	2/2
7	S100-101-199-ZF1-07	Bottom Panel	1	2/2
8	S100-101-199-ZF1-08	Adjustable Shelf Panel	1	2/2
9	S100-101-199-ZF1-09	Shelf Panel	1	2/2
10	S100-101-199-ZF1-10	Back Support Panel	1	2/2
11	S100-101-199-ZF1-11	Top Support Panel	1	2/2
12	S100-101-199-ZF1-12	Right Door	1	1/2
13	S100-101-199-ZF1-13	Left Door	1	1/2
14	S100-101-199-ZF1-14	Drawer Back Panel	1	2/2
15	S100-101-199-ZF1-15	Drawer Support Panel	1	2/2
16	S100-101-199-ZF1-16	Drawer Base	1	2/2
17	S100-101-199-ZF1-17	Back Panel	1	1/2

# HARDWARE LIST

No	Part Name		Qty	Carton
A	M8x30mm Wooden Dowel		x20	1
B	Minifix Cam Bolt <small>(8032t)</small>		x9	1
C	Minifix Cam Nut <small>(1512)</small>		x8	1
D	M3.5x16mm Screw		x52	1
E	M4x45mm Screw		x8	1
F	M4x38mm Screw		x5	1
G	20mm Handle Screw		x8	1
H	Handle <small>(64mm)</small>		x4	1
I	14" Drawer Slide <small>(VKT 0.9 - Black)</small>		x1	1
J	Nail		x50	1
K	Iron Leg <small>(150mm) - Black</small>		x4	1
L	Shelf Support		x4	1
M	Wall Fixing <small>(4x20mm=1pc)</small>		x1	1
N	PVC L-Bracket		x1	1
O	End Hinges <small>(M11)</small>		x6	1
P	Hanging Rail <small>(780mm)</small>		x1	1
Q	Minifix Cam Nut <small>(1510)</small>		x1	1

## TIPS FOR FITTINGS CAM-LOCKS

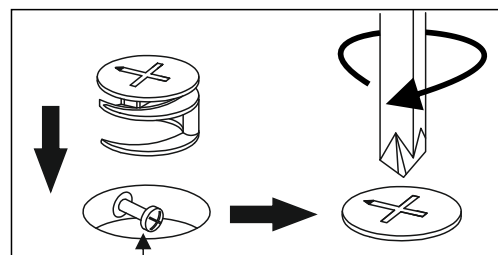
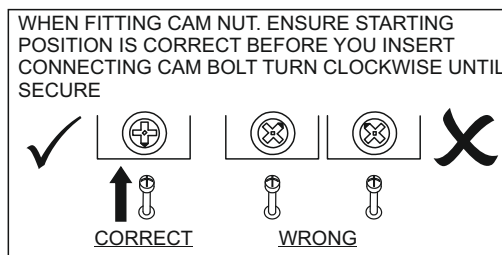

Cam bolt head needs to be in centre

### CAMBOLT

Tighten until shoulder in flush with panel. Do not overtighten or undertighten (see example below)

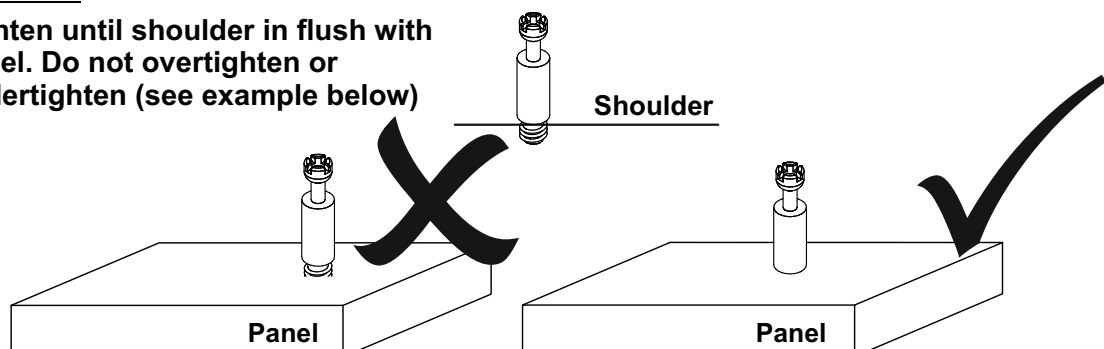

# STEP 1

## PARTS REQUIRED

1 - RIGHT SIDE PANEL x1

2 - LEFT SIDE PANEL x1

## HARDWARE REQUIRED

D  04  
3.5x16mm

I  01

## TOOLS REQUIRED

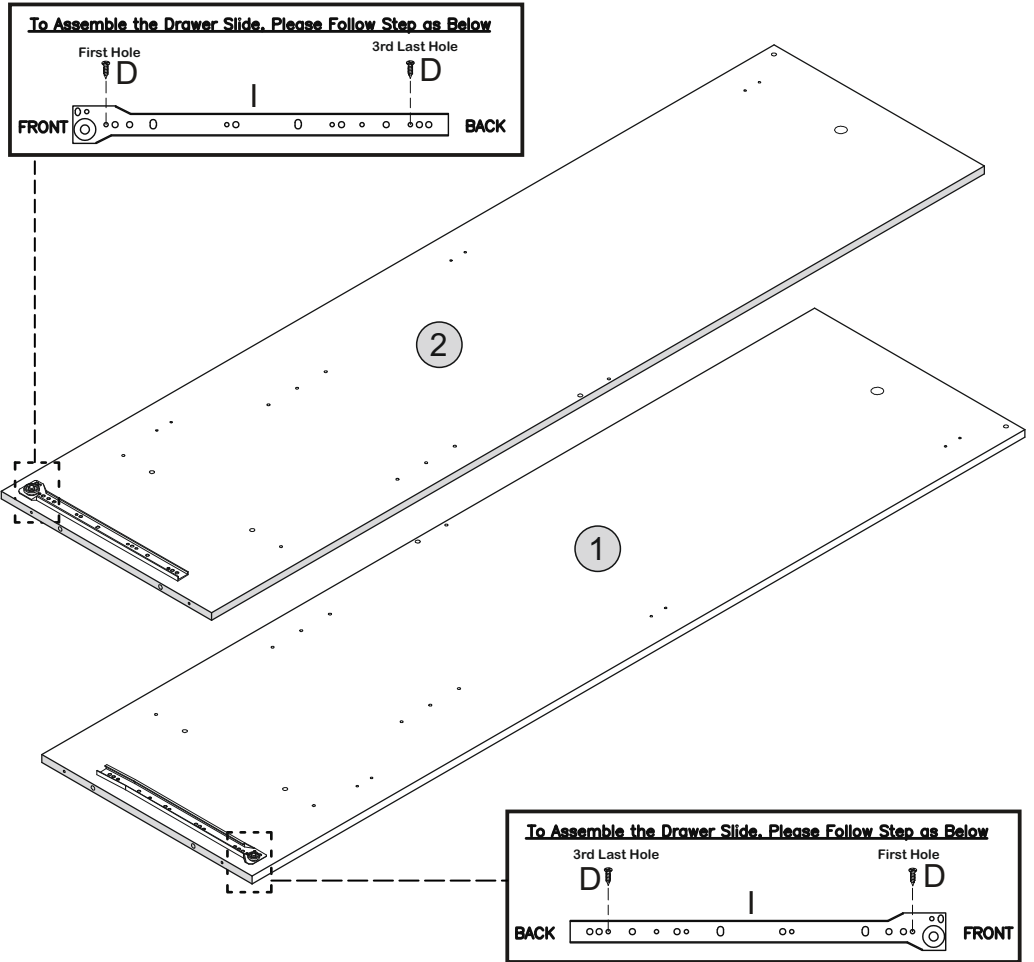
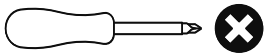

# STEP 2

## PARTS REQUIRED

1 - RIGHT SIDE PANEL x1

2 - LEFT SIDE PANEL x1

## HARDWARE REQUIRED

A  08

B  06

L  04

## TOOLS REQUIRED

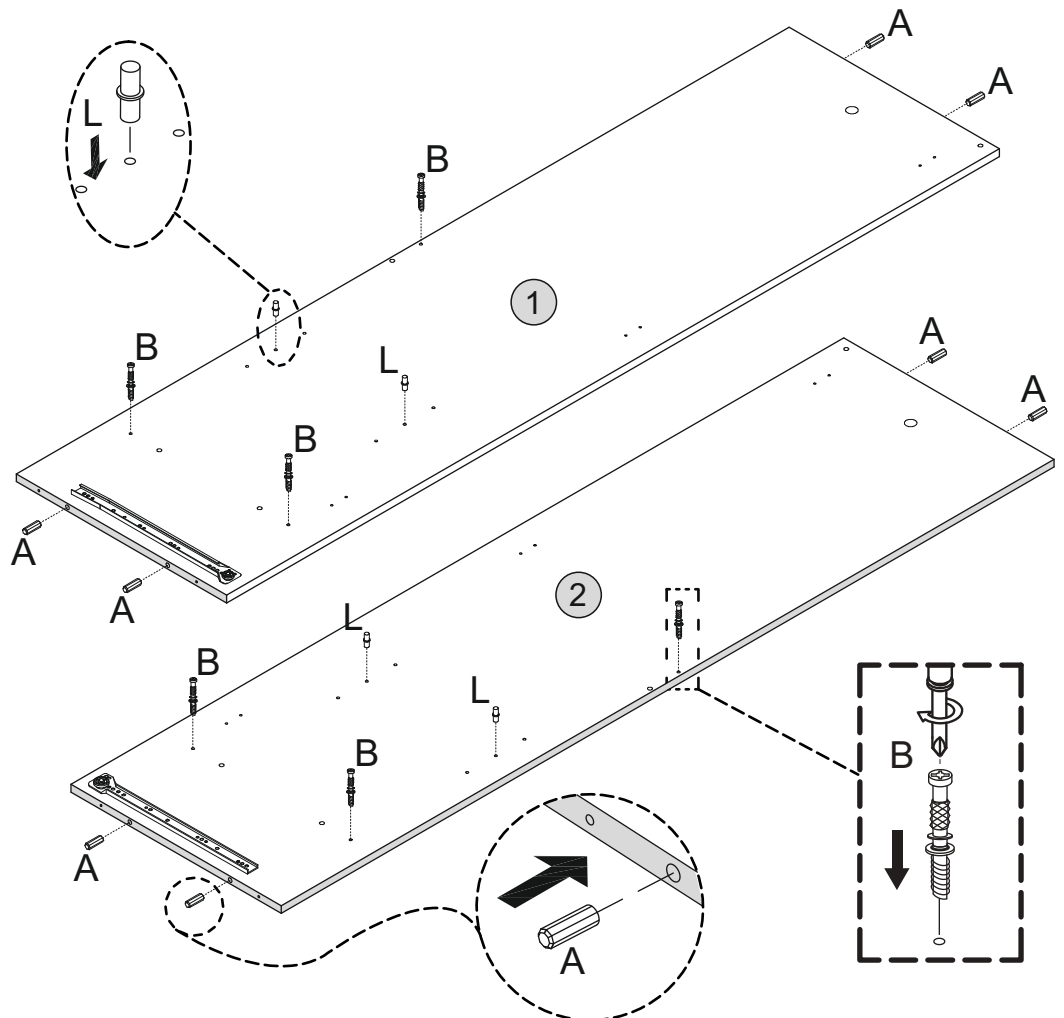
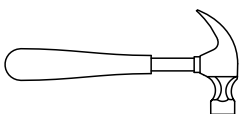
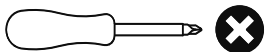



# STEP 3

## PARTS REQUIRED

9 - SHELF PANEL	x1
10 - BACK SUPPORT PANEL	x1
11 - TOP SUPPORT PANEL	x1

## HARDWARE REQUIRED

A		08
C		06

## TOOLS REQUIRED

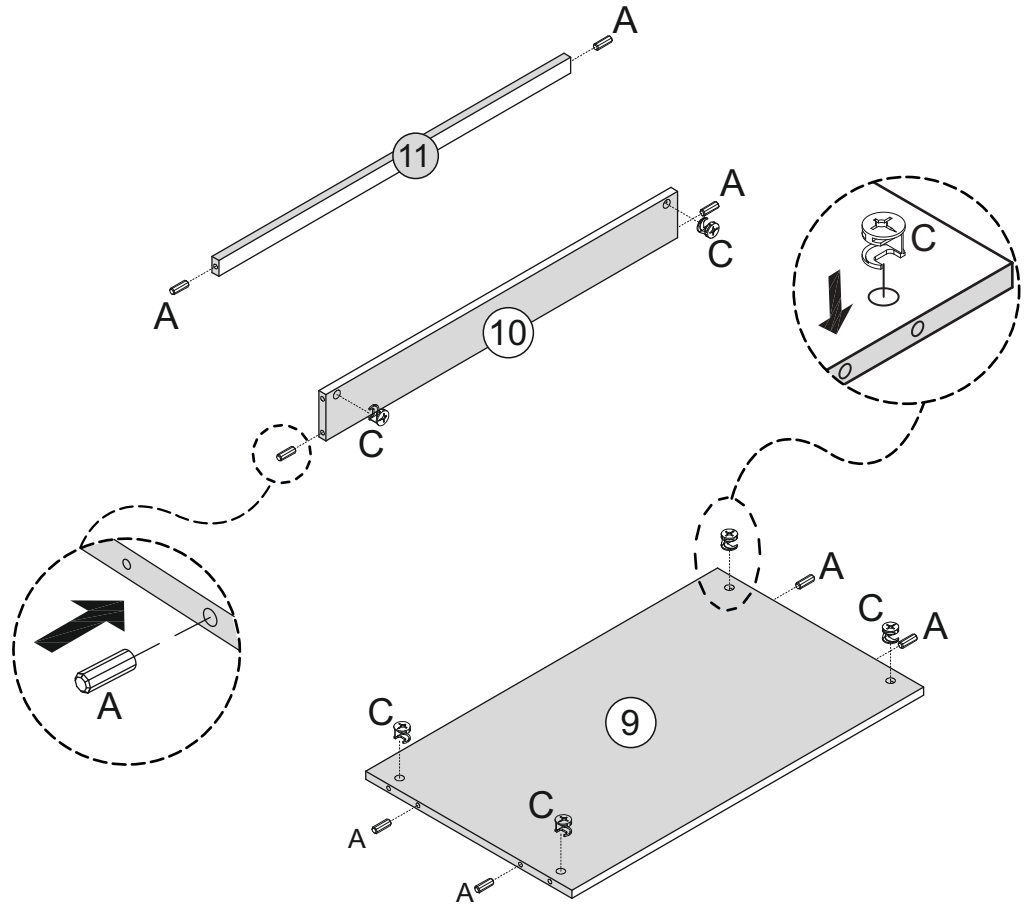
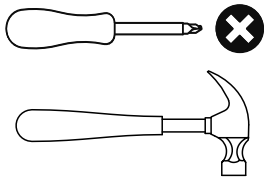



# STEP 4

## PARTS REQUIRED

6 - TOP PANEL	x1
12 - RIGHT DOOR	x1
13 - LEFT DOOR	x1

## HARDWARE REQUIRED

D		13
N		01
O		06

## TOOLS REQUIRED

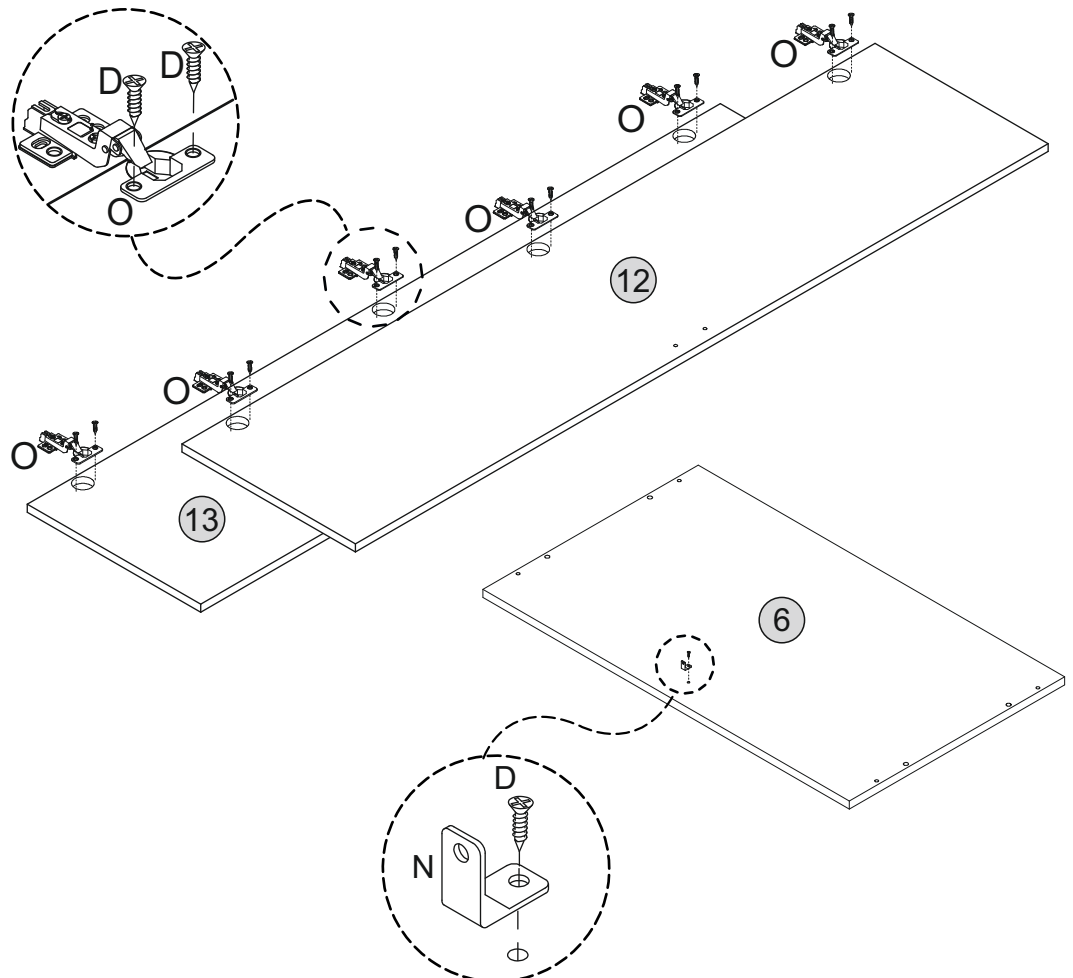
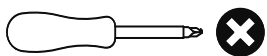

# STEP 5

## PARTS REQUIRED

- 1 - RIGHT SIDE PANEL x1
- 9 - SHELF PANEL x1
- 10 - BACK SUPPORT PANEL x1

## HARDWARE REQUIRED

### TOOLS REQUIRED

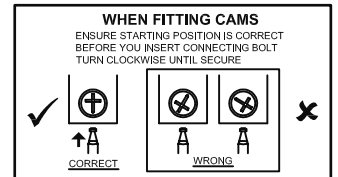
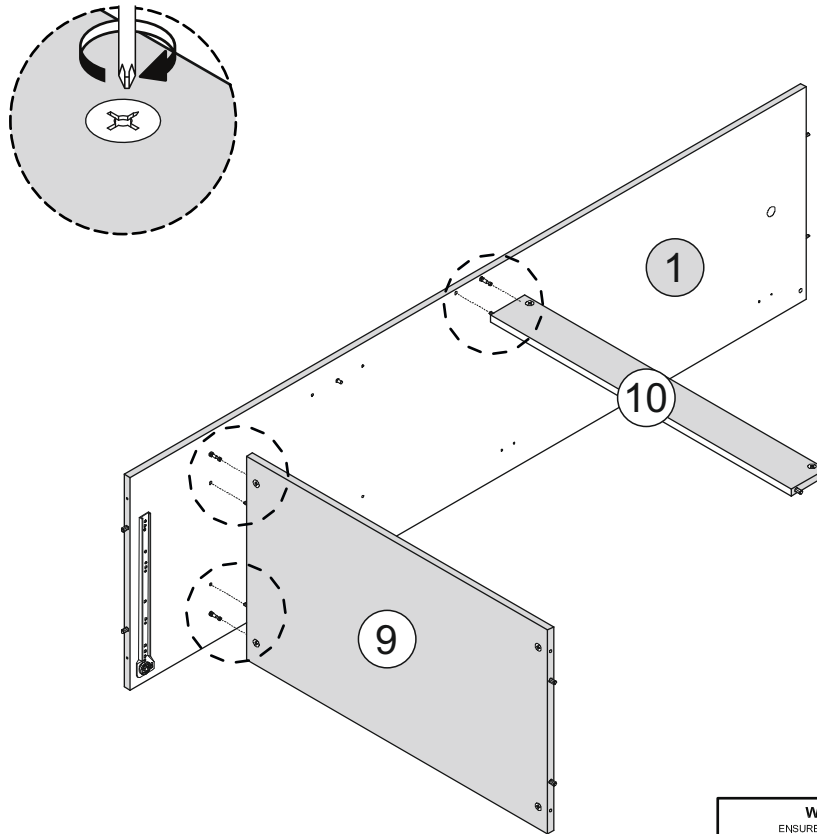
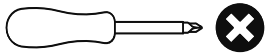

# STEP 6

## PARTS REQUIRED

- 2 - LEFT SIDE PANEL x1
- 11 - TOP SUPPORT PANEL x1

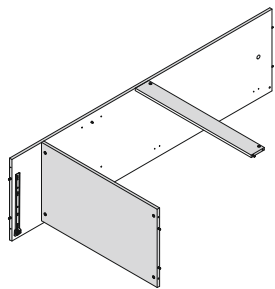

## HARDWARE REQUIRED

- P 01

### TOOLS REQUIRED

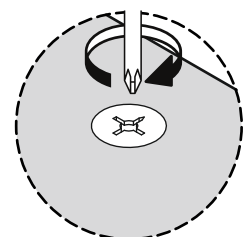
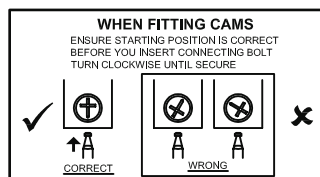
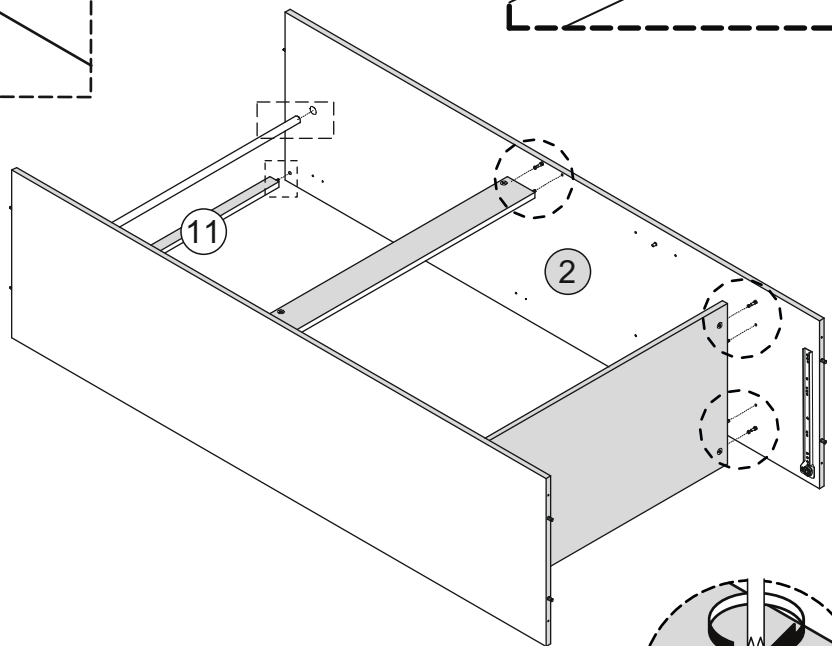
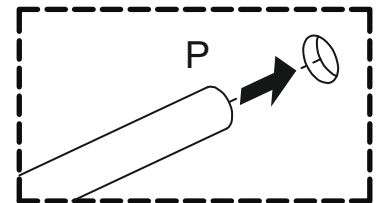
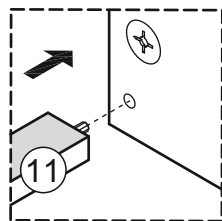
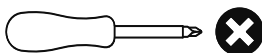

# STEP 7

## PARTS REQUIRED

6 - TOP PANEL x1

7 - BOTTOM PANEL x1

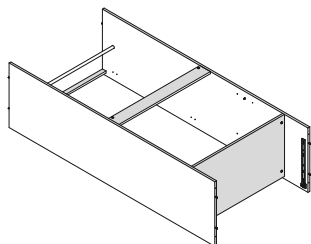

## HARDWARE REQUIRED

E  4x45mm 08

## TOOLS REQUIRED

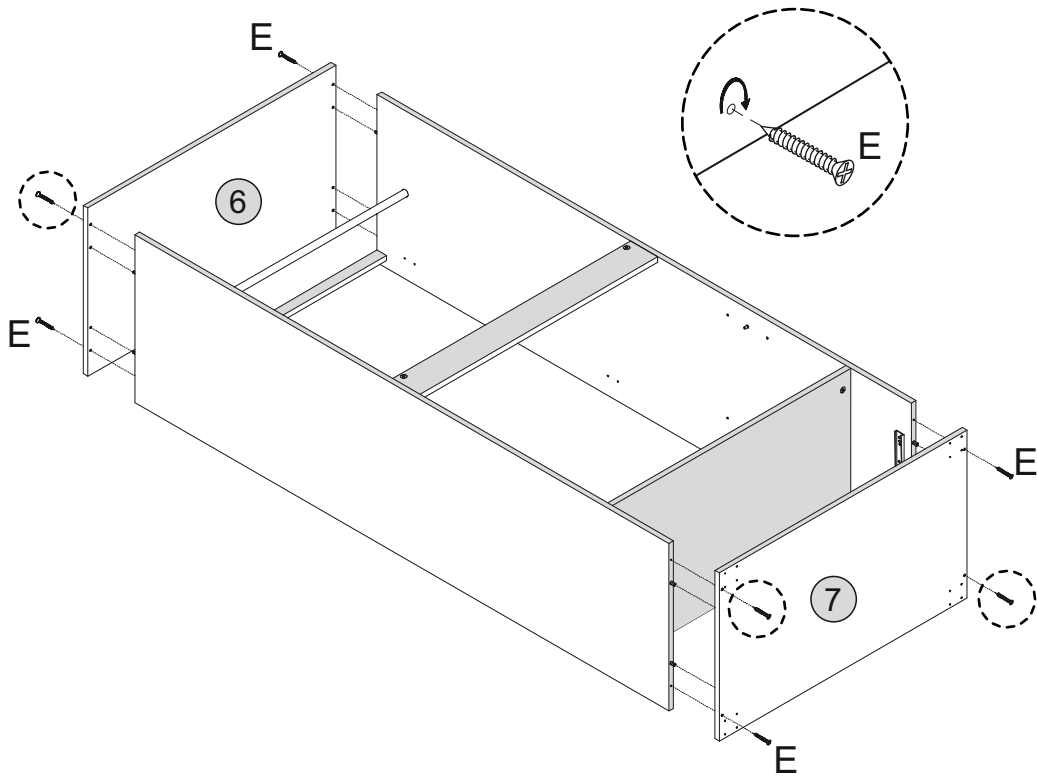
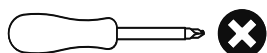

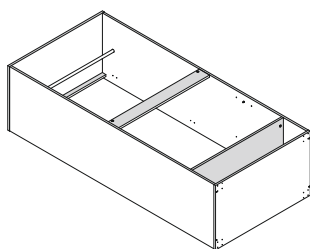

# STEP 8

## PARTS REQUIRED



## HARDWARE REQUIRED

D  3.5x16mm 19

K  04

## TOOLS REQUIRED

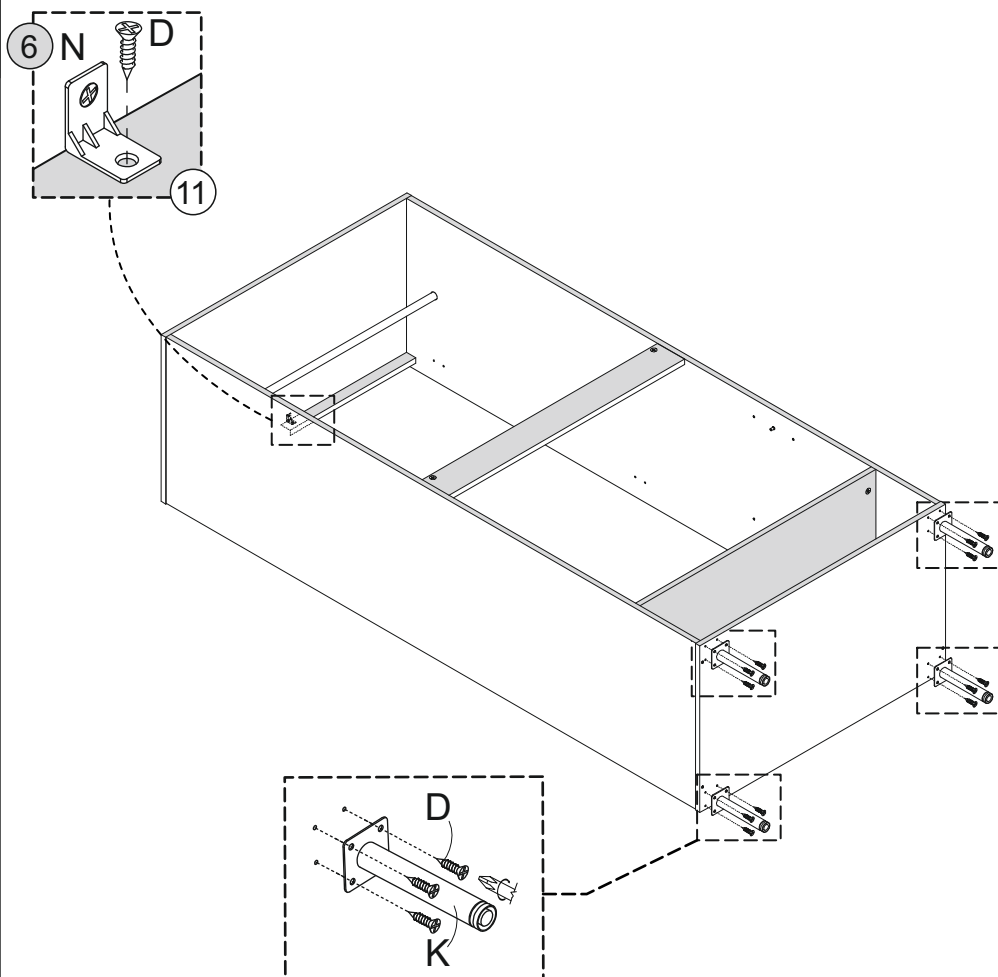
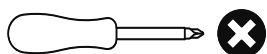

# STEP 9

## PARTS REQUIRED

17 - BACK PANEL x1

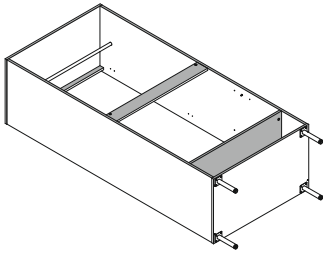

## HARDWARE REQUIRED

D  02  
3.5x16mm

J  50

## TOOLS REQUIRED

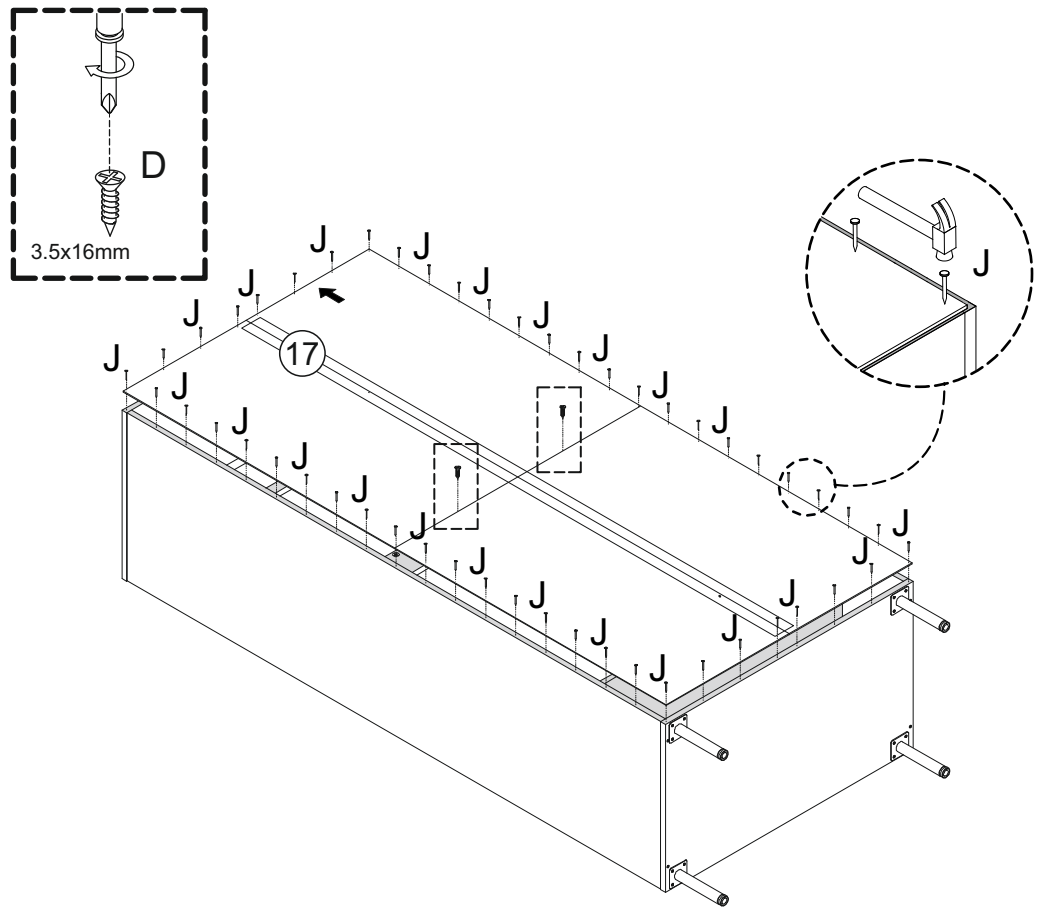
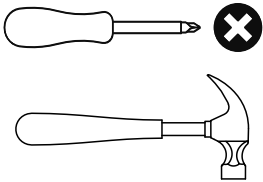

# STEP 10

## PARTS REQUIRED

3 - DRAWER FRONT x1

4 - RIGHT DRAWER SIDE x1

5 - LEFT DRAWER SIDE x1

15 - DRAWER SUPPORT x1

## HARDWARE REQUIRED

A  04

B  03

C  02

Q  01

## TOOLS REQUIRED

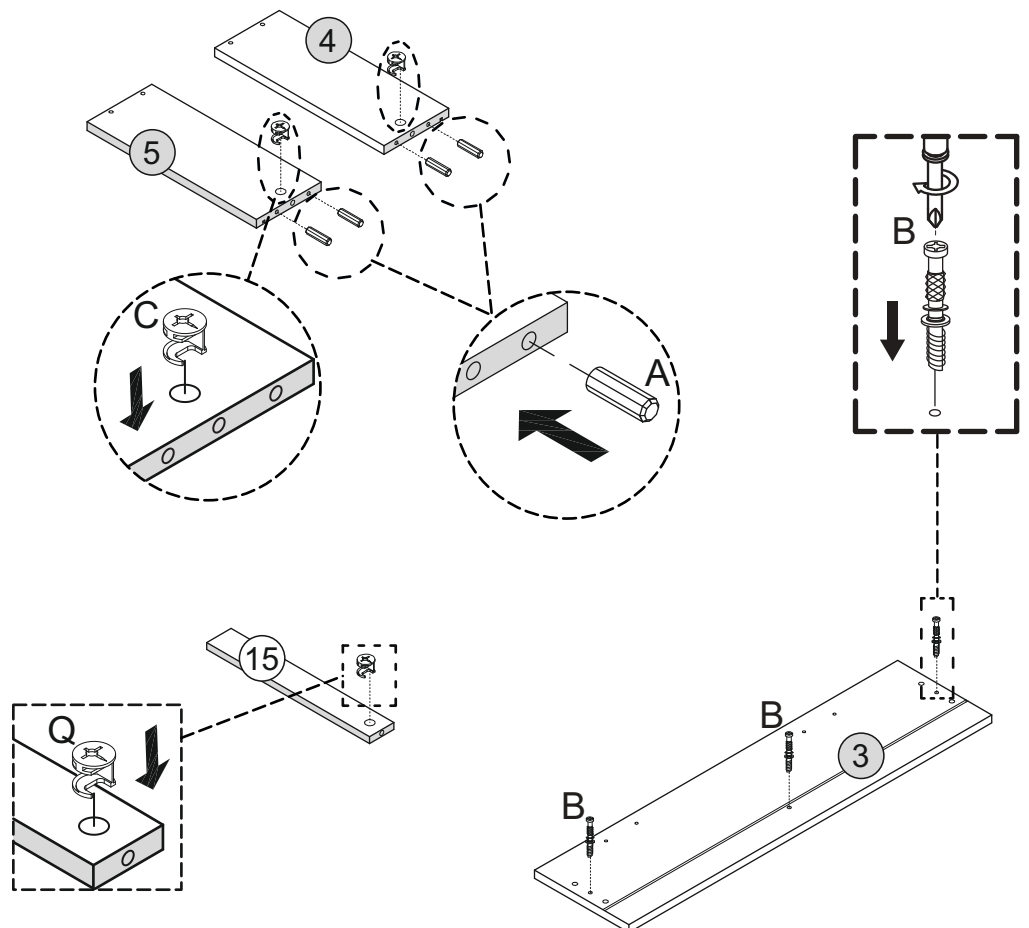
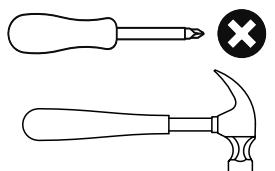



# STEP 11

## PARTS REQUIRED

- 4 - RIGHT DRAWER SIDE x1
- 5 - LEFT DRAWER SIDE x1
- 14 - DRAWER BACK x1
- 15 - DRAWER SUPPORT x1
- 16 - DRAWER BASE x1

## HARDWARE REQUIRED

- F  05

## TOOLS REQUIRED

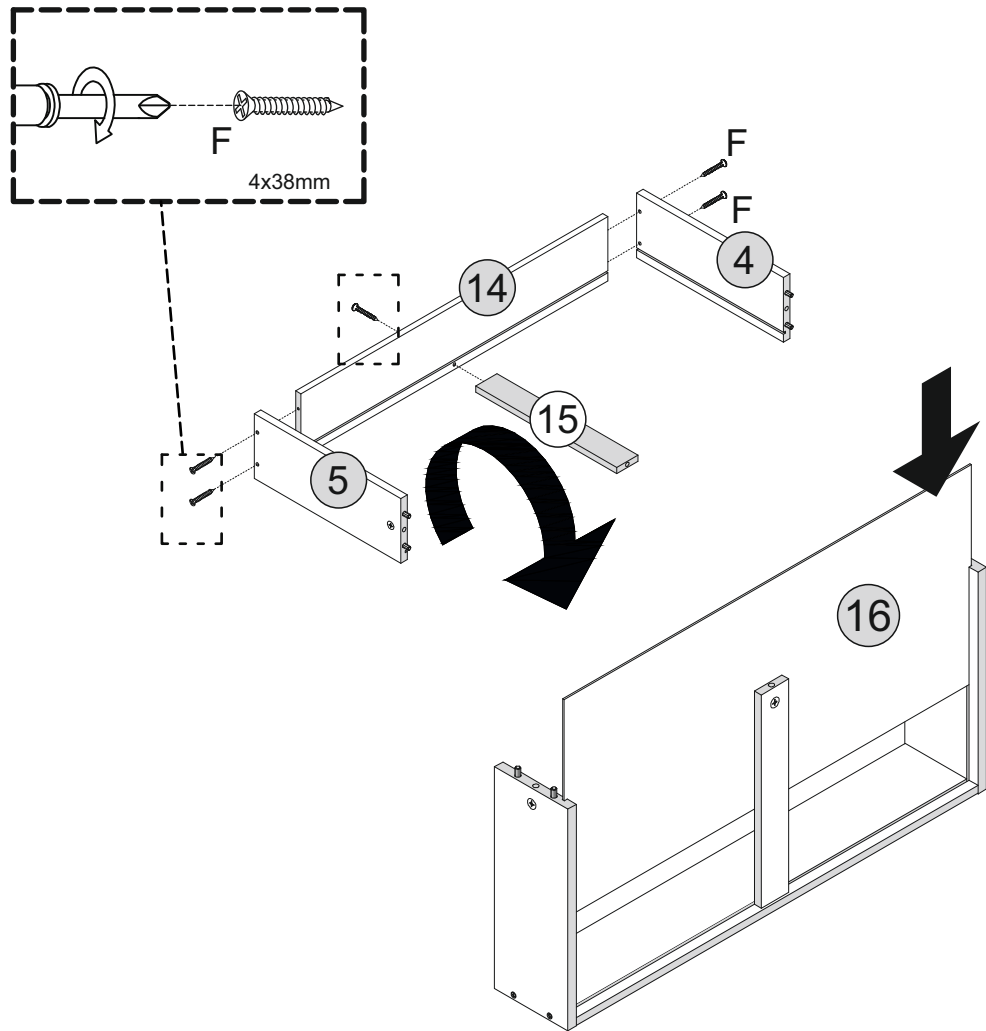
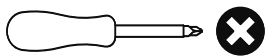

# STEP 12

## PARTS REQUIRED

- 3 - DRAWER FRONT x1

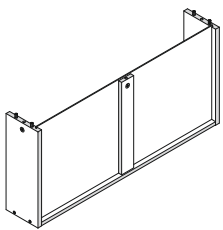

## HARDWARE REQUIRED

## TOOLS REQUIRED

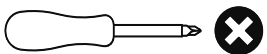

**WHEN FITTING CAMS**  
 ENSURE STARTING POSITION IS CORRECT  
 BEFORE YOU INSERT CONNECTING BOLT  
 TURN CLOCKWISE UNTIL SECURE

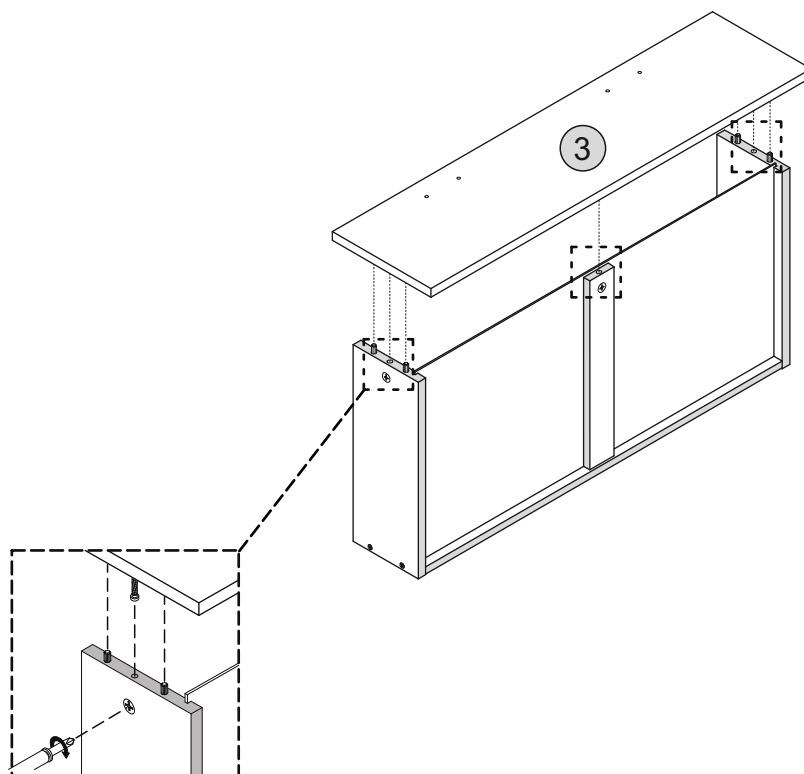

# STEP 13

PARTS REQUIRED

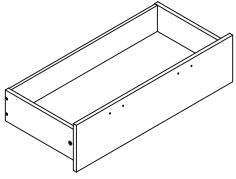

HARDWARE REQUIRED

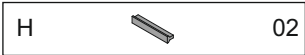

TOOLS REQUIRED

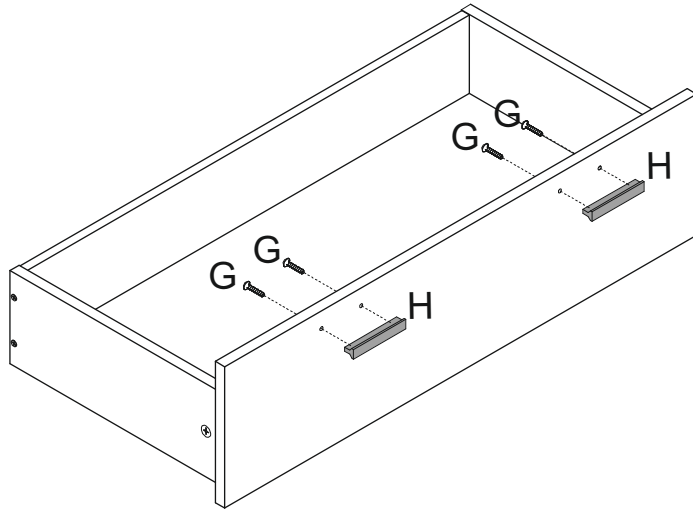
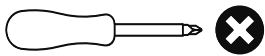

# STEP 14

PARTS REQUIRED

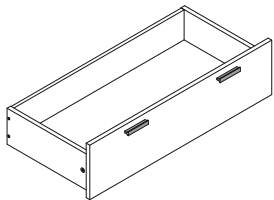

HARDWARE REQUIRED

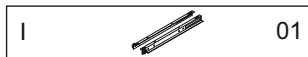
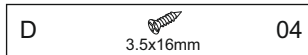

TOOLS REQUIRED

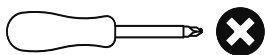

Turn Back

**FRONT**

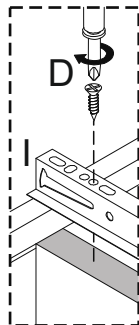

**BACK**

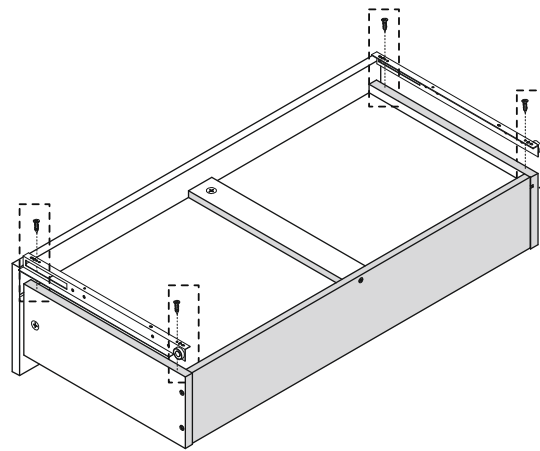
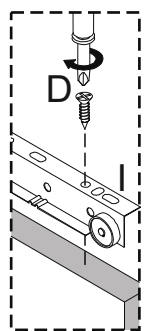

# STEP 15

## PARTS REQUIRED

8 - ADJUSTABLE SHELF PANEL x1

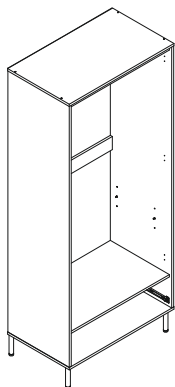

## HARDWARE REQUIRED

## TOOLS REQUIRED

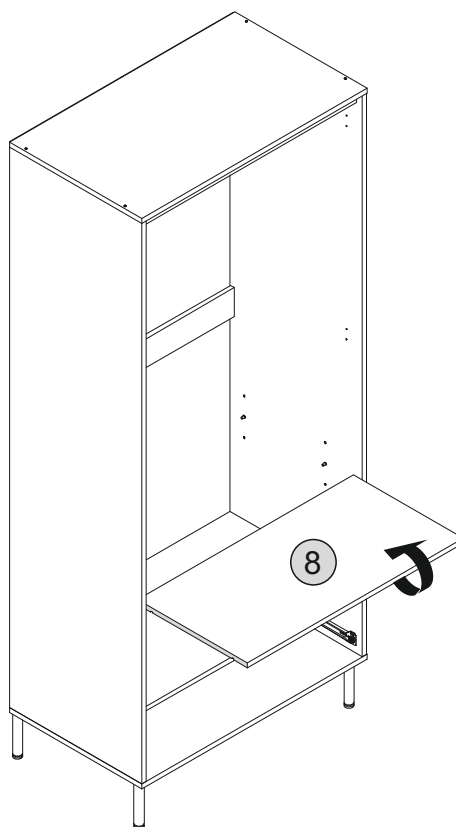

# STEP 16

## PARTS REQUIRED

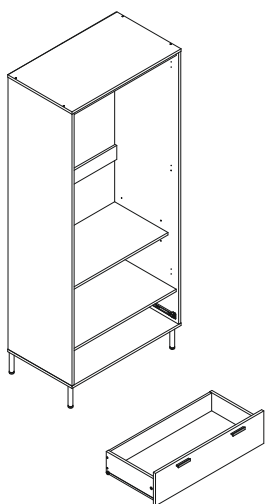

## HARDWARE REQUIRED

## TOOLS REQUIRED

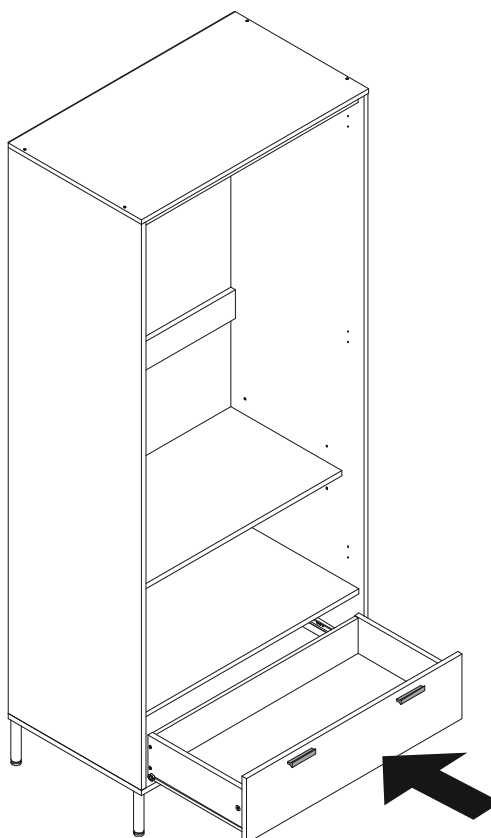

# STEP 17

## PARTS REQUIRED

12 - RIGHT DOOR x1

13 - LEFT DOOR x1

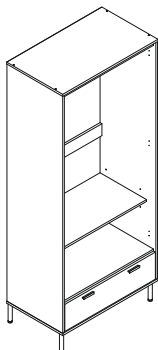

## HARDWARE REQUIRED

D  12  
3.5x16mm

G  04

H  02

## TOOLS REQUIRED

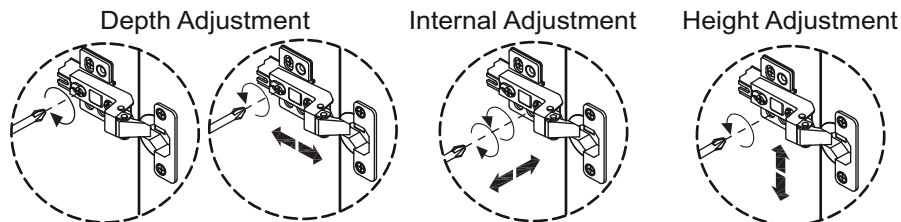
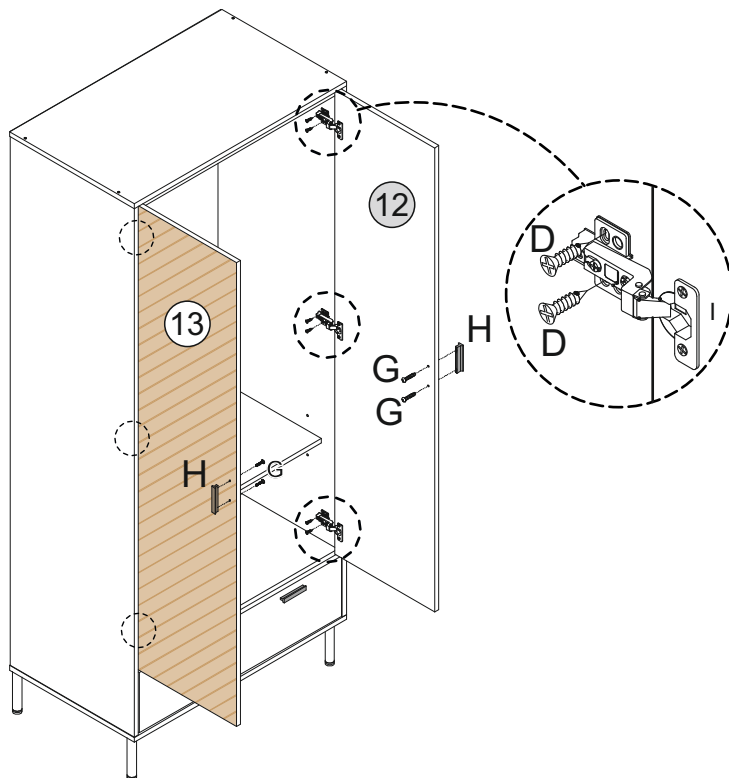
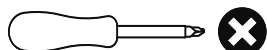

# STEP 18

## PARTS REQUIRED

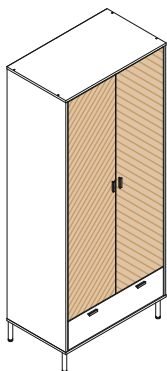

## HARDWARE REQUIRED

M  01

## TOOLS REQUIRED

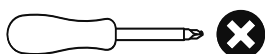

## WARNING

**Serious or fatal injuries can occur from furniture tipping over. To prevent the furniture from tipping over we recommend that it is permanently fixed to the wall.**

Wall fixings are not supplied with this product as different wall materials require different types of fixing devices. Please make sure you use fixings suitable for the walls in your home.

