

# NEVADA 6 DOOR 2 DRAWER WARDROBE ASSEMBLY INSTRUCTIONS

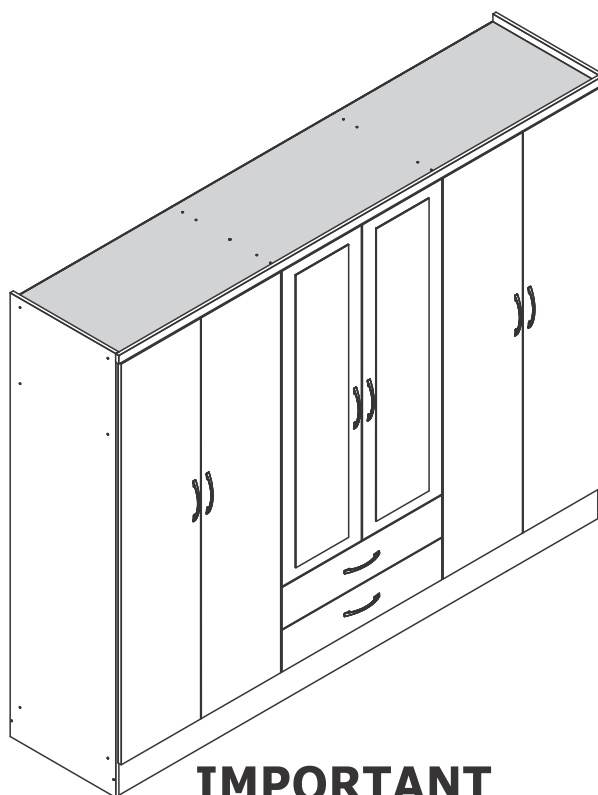

**IMPORTANT**  
**FOR DOMESTIC USE ONLY**  
**PLEASE READ BEFORE YOU CONTINUE FURTHER**

## CARE AND MAINTENANCE

- After unpacking this product please keep the original packaging in case it needs to be returned for any reason.
- Please ensure all fittings and parts are present before commencing with assembly.
  - Never drag or push products as this could cause damage to the joints making it inferior.
  - We strongly recommend that you keep children away from your work area.
  - We recommend that you lay a blanket or sheet on the floor to avoid damage to both your floor and the product.
  - Assemble this product as close to its final position as possible.
  - Do not place this product next to a radiator or in direct sunlight.
  - Do not drag or push items across your high gloss furniture as this may cause the surface to scratch
  - Wood is a natural product and may expand if subjected to damp and may shrink or crack if subjected to heat. Therefore it is recommended that room temperature is maintained, with no sudden temperature fluctuations.
  - Make sure any spillage is wiped off immediately.
  - Do not place hot or chilled items directly on to the surface, use a place mat or marking will occur.
  - For general cleaning use a soft cotton or micro fibre cloth, and do not use detergents of any kind.
  - From time to time it may be necessary to tighten fittings, regular inspections should be carried out.
  - Do not place on a wet or damp floor as staining may occur to your floor.

\* For your future reference  
Order Number should be here

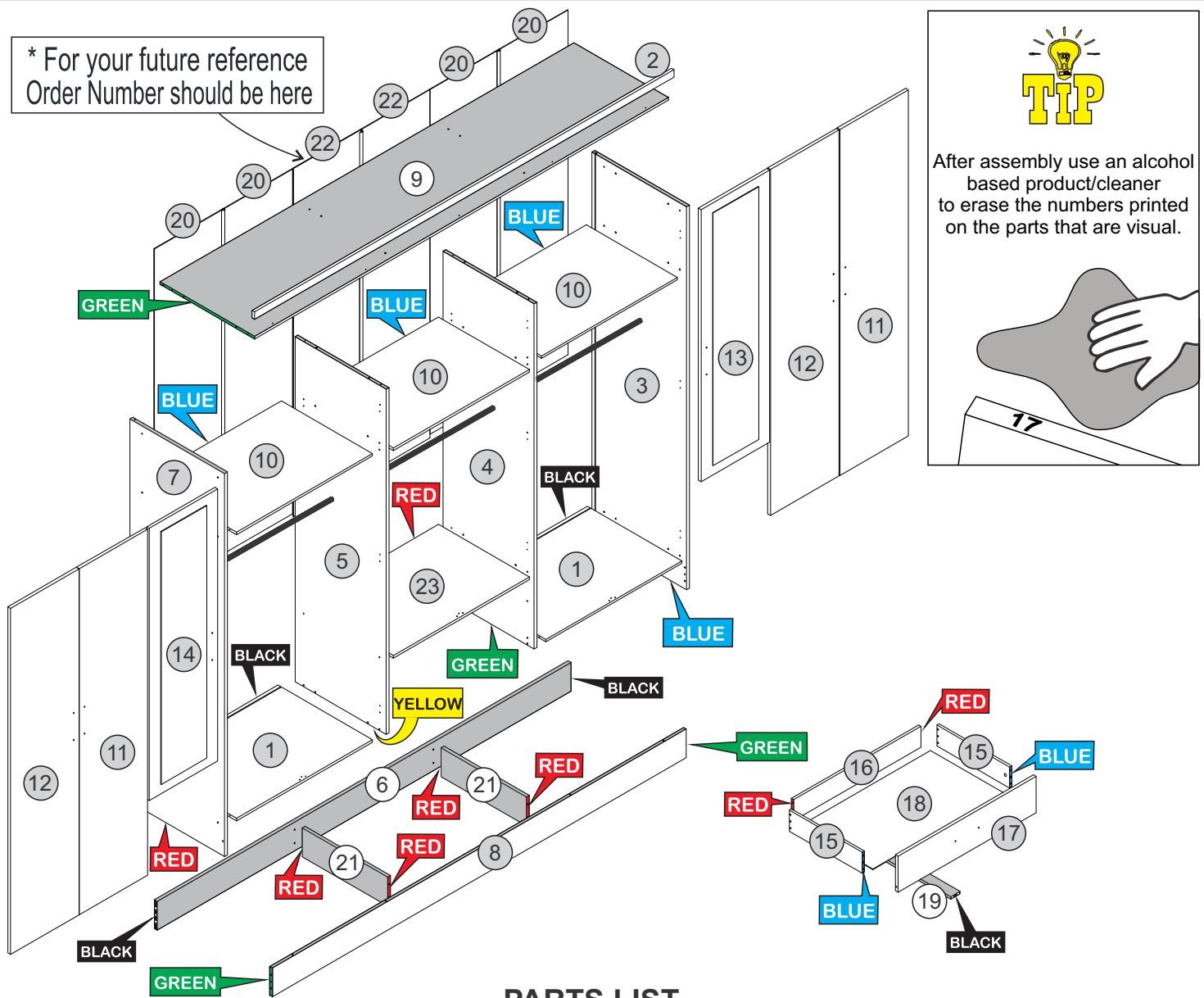







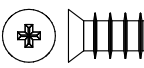
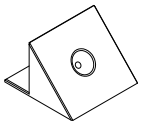
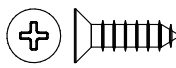
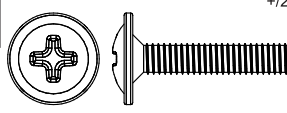
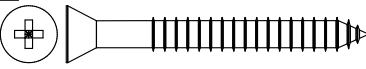
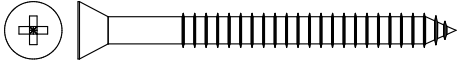
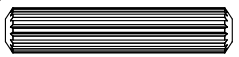

### PARTS LIST

**Please Note:**

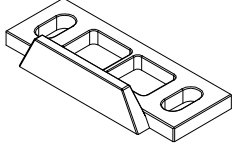
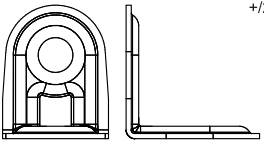
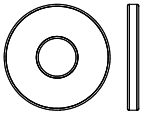
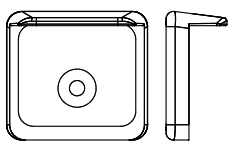
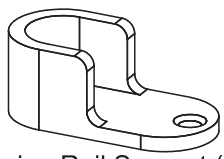
The below parts have all been stamped with the part number/color to help identify them during assembly.

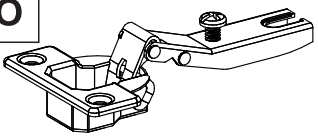
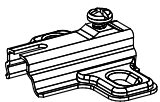
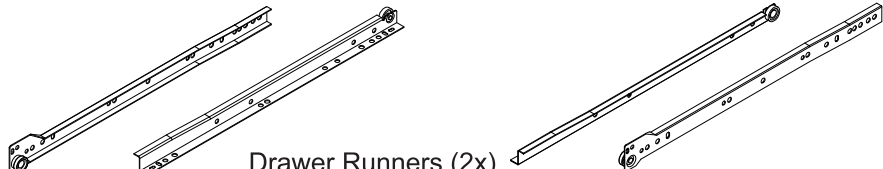
Part Number	Part Description	Quantity	Carton
1	Base Panel - Black	2	2/4
2	Frame	1	3/4
3	Right Side Panel - Blue	1	1/4
4	Right Division Panel - Green	1	1/4
5	Left Division Panel - Yellow	1	2/4
6	Back Baseboard - Black	1	3/4
7	Left Side Panel - Red	1	1/4
8	Front Baseboard - Green	1	3/4
9	Top Panel - Green	1	3/4
10	Upper Panel - Blue	3	2/4
11	Right Large Door	2	4/4
12	Left Lagre Door	2	3/4
13	Right Small Door	1	4/4
14	Left Small Door	1	4/4
15	Drawer Side - Blue	4	1/4
16	Drawer Back Panel - Red	2	1/4
17	Drawer Front	2	1/4
18	Drawer Bottom	2	2/4
19	Drawer Bottom Support Bar - Black	2	1/4
20	Back Panel	4	4/4
21	Central Baseboard - Red	2	1/4
22	Centre Back Panel	2	2/4
23	Shelf Over Drawer - Red	1	2/4



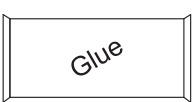
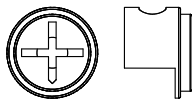
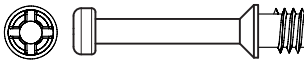
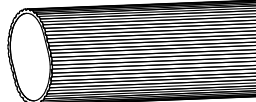
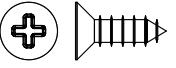
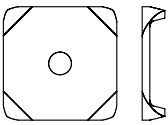
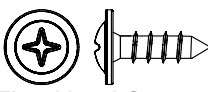
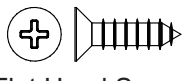

### FITTINGS LIST

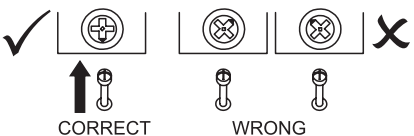

<b>A</b>  +/1 Flat Head Screw Ø6,0 x 10mm (8x)	<b>B</b>  2/+ Plastic Corner Bracket (12x)	<b>C</b>  +/2 Flat Head Screw Ø4,0 x 14 mm (96x)	<b>D</b>  +/2 Flan Head Screw Ø4,0 x 20mm (16x)
<b>E</b>  +/1 Flat Head Screw Ø3,5 x 40mm (4x)	<b>F</b>  +/2 Flat Head Screw Ø4,0 x 50 mm (44x)	<b>G</b>  +/2 Dowel Ø6,0 x 30mm (76x)	
<b>H</b>  +/2 Nail 10 x 10 (70x)	<b>I</b>  +/1 Door Stopper (6x)	<b>J</b>  +/2 'L' Metallic Support (11x)	<b>K</b>  +/1 Washer (4x)
<b>L</b>  +/1 Plastic Foot (8x)	<b>M</b>  +/1 Hanging Rail Support (6x)	<b>N</b>  +/1 Flan Head Screw Ø3,5 x 30mm (2x)	<b>O</b>  +/1 Hinge (18x)
<b>P</b>  +/1 Hinge Plate (18x)	<b>Q</b>  +/1 Drawer Runners (2x)		
<b>R</b>  +/1 Back Panel Strip (3x)	<b>S</b>  +/1 Strap (2x)	<b>T</b>  +/1 Handle (8x)	<b>U</b>  +/2 Hole Plugs (38x)
<b>V</b>  +/1 Glue (2x)	<b>W</b>  +/1 Cam Nut (4x)	<b>X</b>  +/1 Cam Bolt (4x)	<b>Y</b>  +/1 Hanging Rail (3x)
<b>Z</b>  +/2 Flat Head Screw Ø4,0 x 12mm (34x)	<b>A1</b>  2/+ Back Panel Bracket (16x)	<b>B1</b>  1/+ Flan Head Screw 3,5 x14mm (6x)	<b>C1</b>  2/+ Flat Head Screw 3,5 x16mm (12x)

### TIPS FOR FITTINGS CAM-LOCKS

WHEN FITTING A CAM NUT. ENSURE STARTING POSITION IS CORRECT BEFORE YOU INSERT CONNECTING CAM BOLT TURN CLOCKWISE UNTIL SECURE



  

CORRECT      WRONG

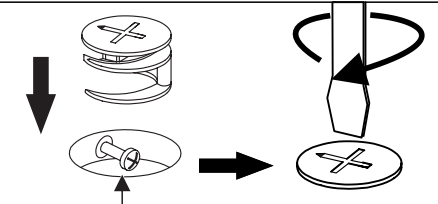

Cam bolt head needs to be in centre

### TOOLS REQUIRED

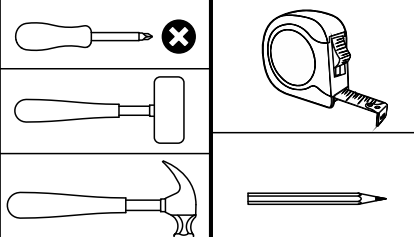

### CAMBOLT

Tighten until shoulder is flush with panel. Do not overtighten or undertighten (see example beside)

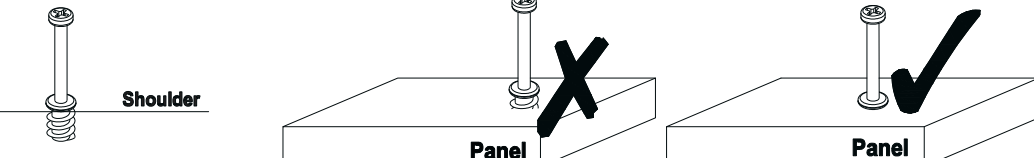

Shoulder      Panel      Panel

# STEP 1

## PARTS REQUIRED

1 - BASE PANEL - BLACK x2

10 - UPPER PANEL - BLUE x3

23 - SHELF OVER DRAWER - RED x1

## HARDWARE REQUIRED

G  24  
Ø6,0 x 30mm

V  01

## TOOLS REQUIRED

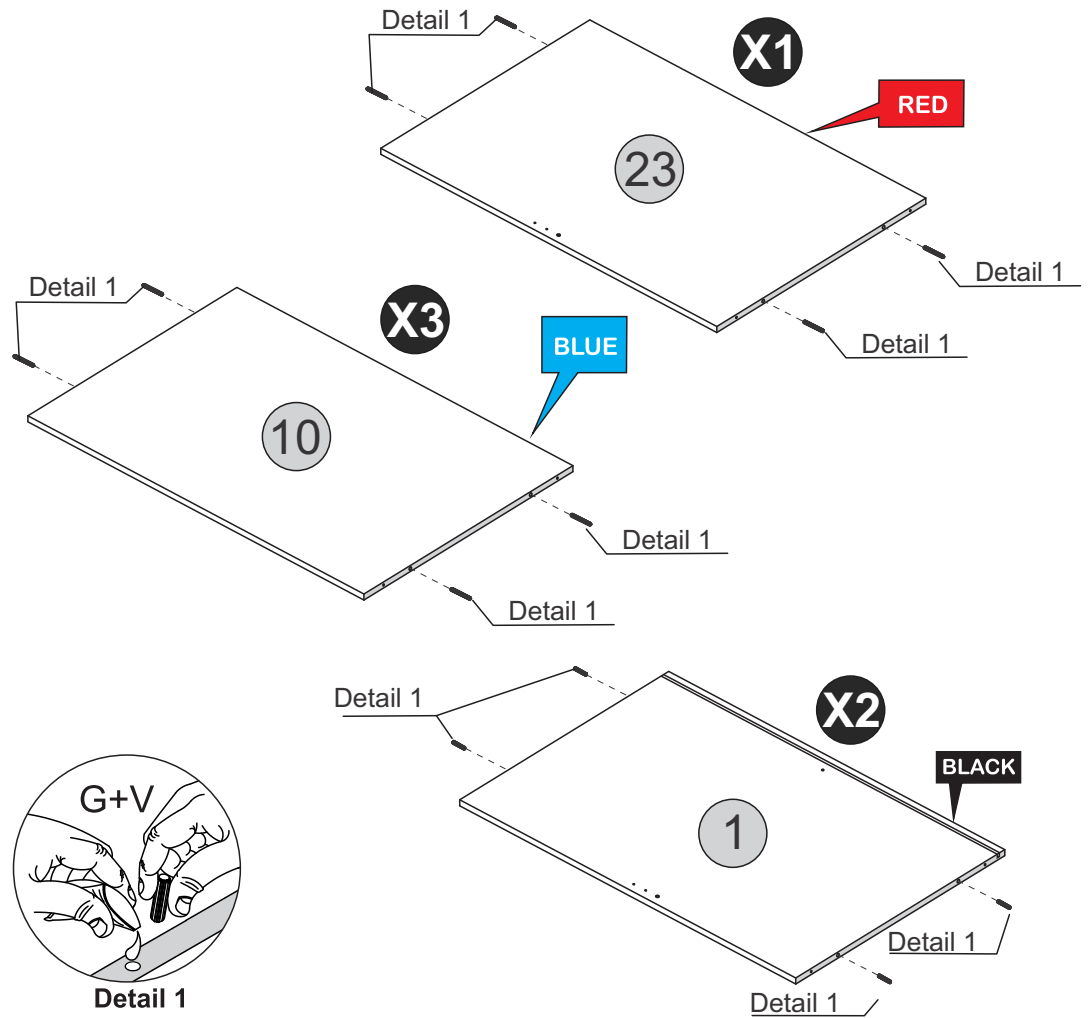
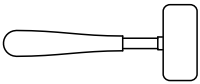

# STEP 2

## PARTS REQUIRED

6 - BACK BASEBOARD - BLACK x1

8 - FRONT BASEBOARD - GREEN x1

## HARDWARE REQUIRED

G  16  
Ø6,0 x 30mm

H  04

L  04

V  01

## TOOLS REQUIRED

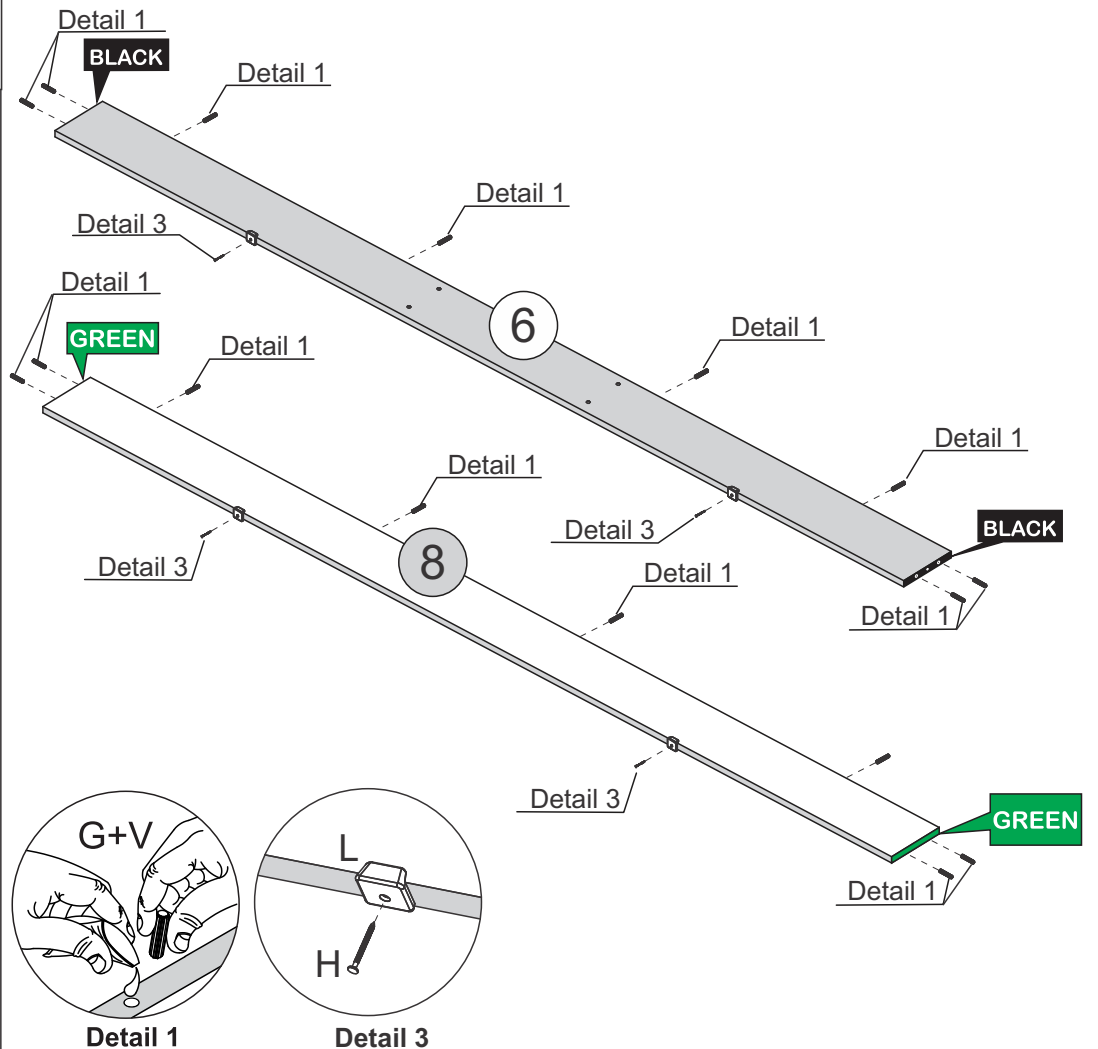
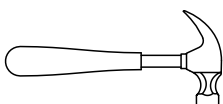
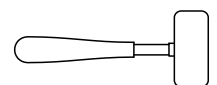



# STEP 3

## PARTS REQUIRED

5 - LEFT DIVISION PANEL - YELLOW x1

## HARDWARE REQUIRED

C  08  
Ø4,0 x 14mm

G  02  
Ø6,0 x 30mm

M  01

P  03

V  01

## TOOLS REQUIRED

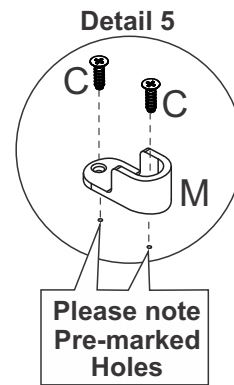
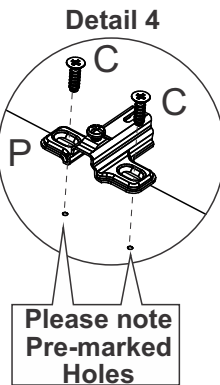
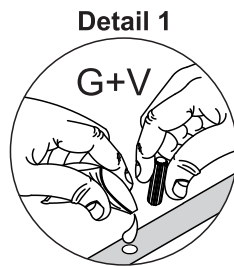
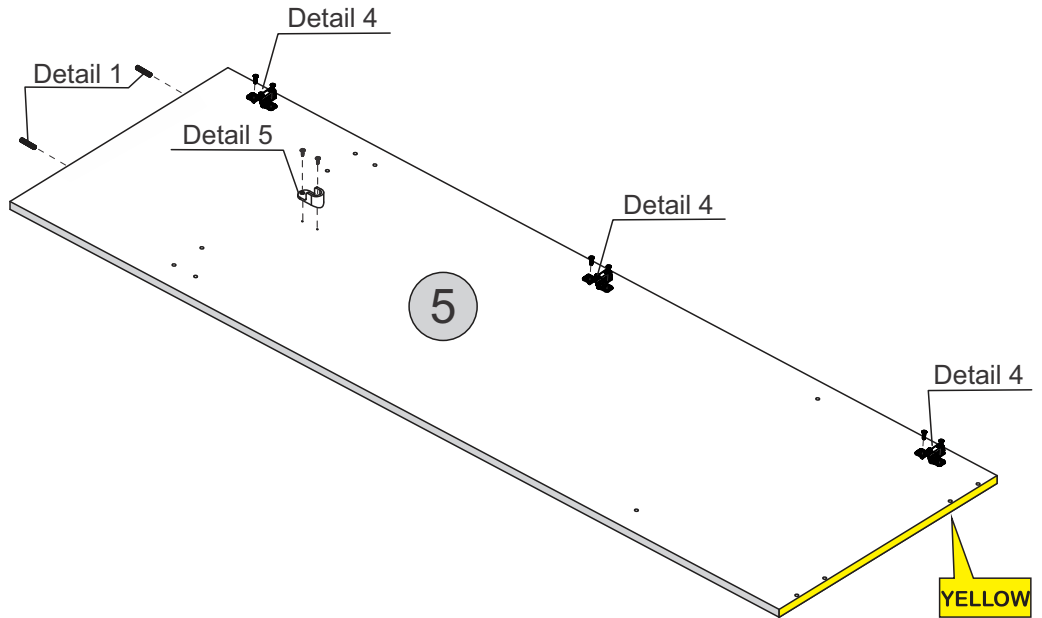
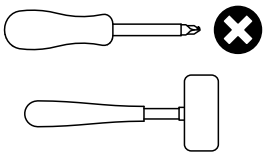

# STEP 4

## PARTS REQUIRED

5 - LEFT DIVISION PANEL - YELLOW x1

## HARDWARE REQUIRED

A  04  
Ø6,0 x 10mm

C  08  
Ø4,0 x 14mm

M  01

P  03

Q  Left 02

## TOOLS REQUIRED

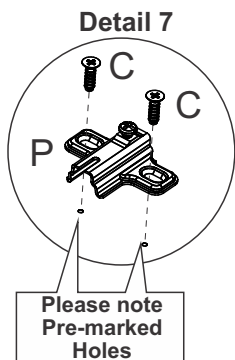
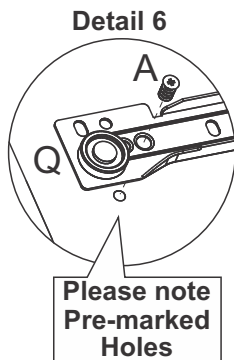
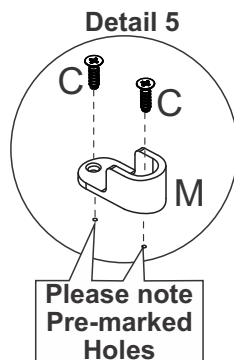
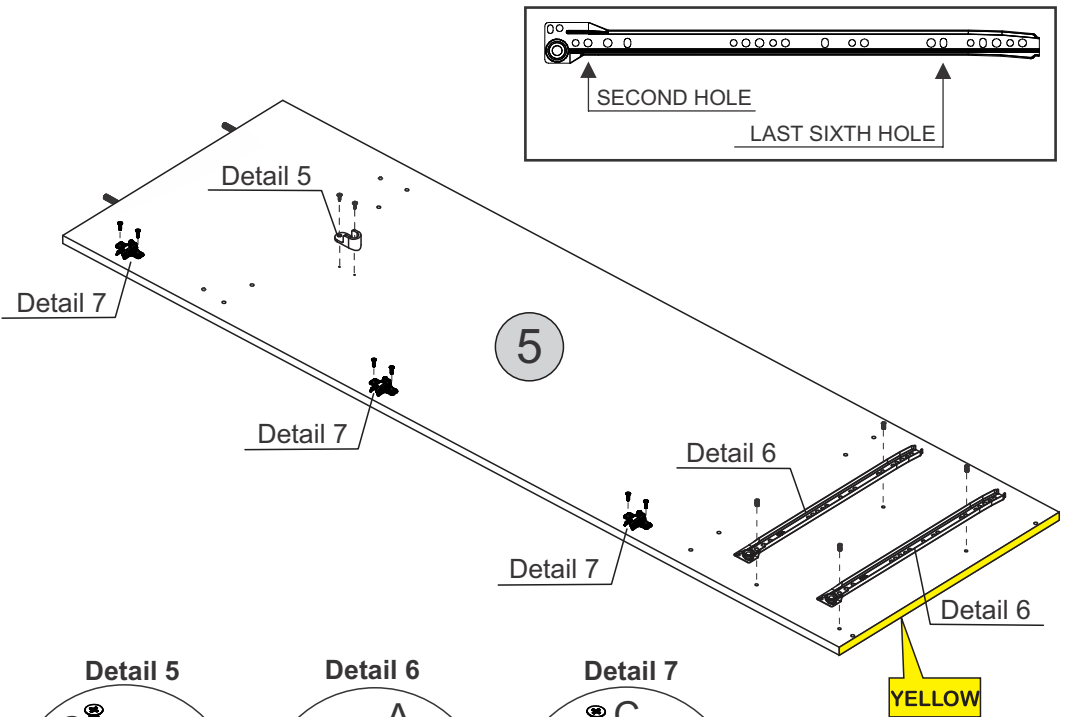
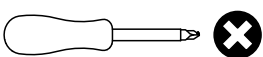



# STEP 5

## PARTS REQUIRED

4 - RIGHT DIVISION PANEL - GREEN x1

## HARDWARE REQUIRED

C  08  
Ø4,0 x 14mm

G  02  
Ø6,0 x 30mm

M  01

P  03

V  01

## TOOLS REQUIRED

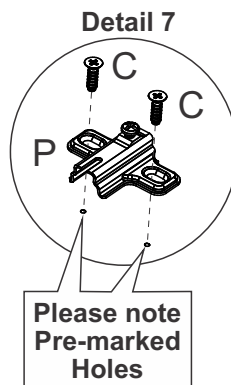
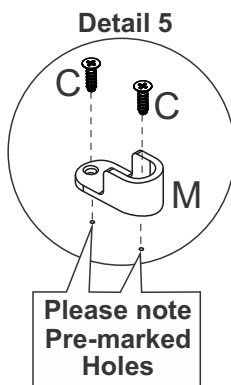
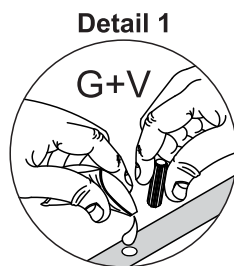
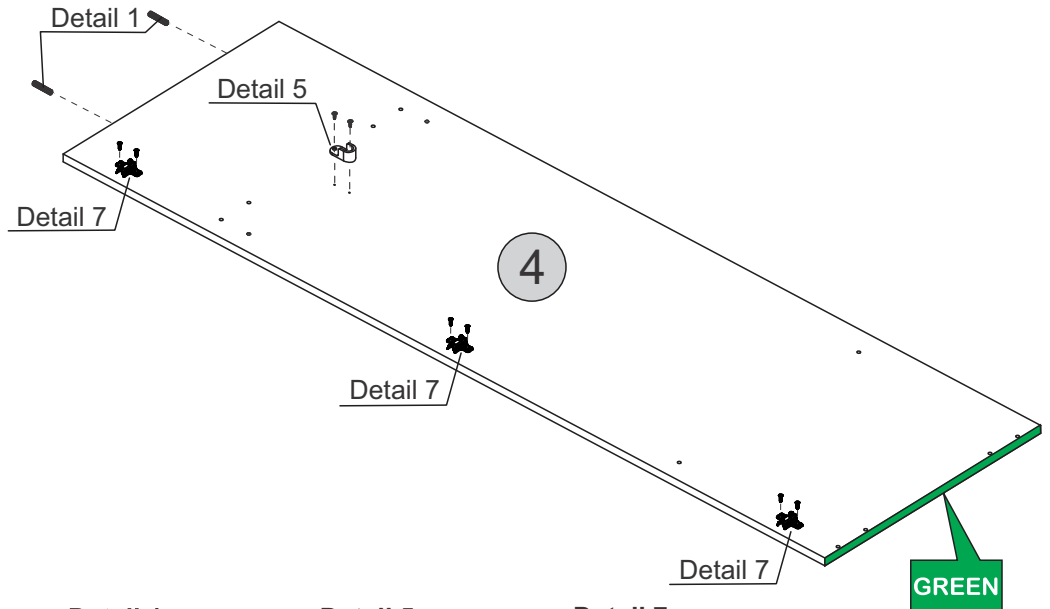
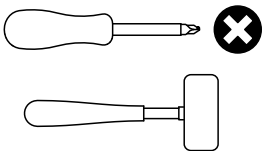

# STEP 6

## PARTS REQUIRED

4 - RIGHT DIVISION PANEL - GREEN x1

## HARDWARE REQUIRED

A  04  
Ø6,0 x 10mm

C  08  
Ø4,0 x 14mm

M  01

P  03

Q  02  
Right

## TOOLS REQUIRED

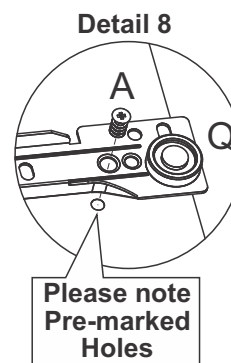
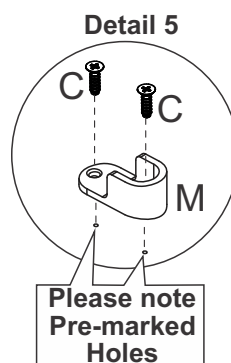
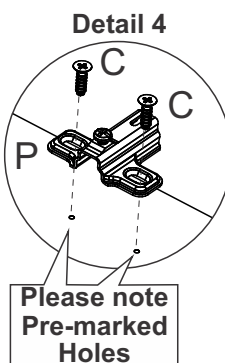
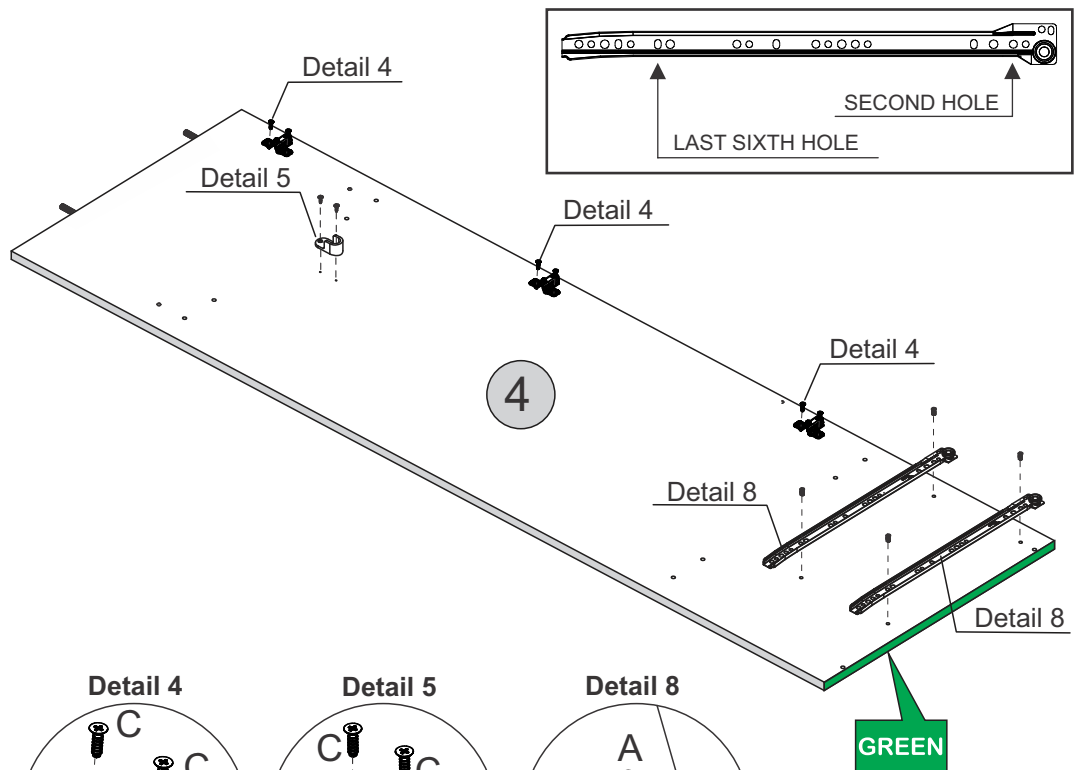
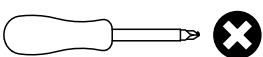

# STEP 7

## PARTS REQUIRED

3 - RIGHT SIDE PANEL - BLUE x1

## HARDWARE REQUIRED

C  08  
Ø4,0 x 14mm

H  02

L  02

M  01

P  03

## TOOLS REQUIRED

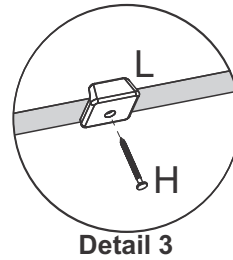
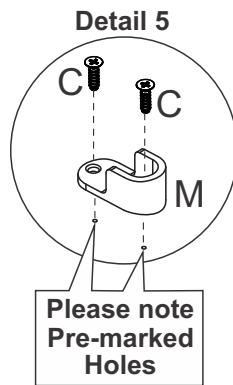
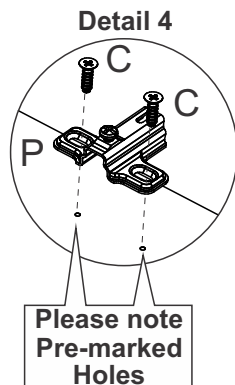
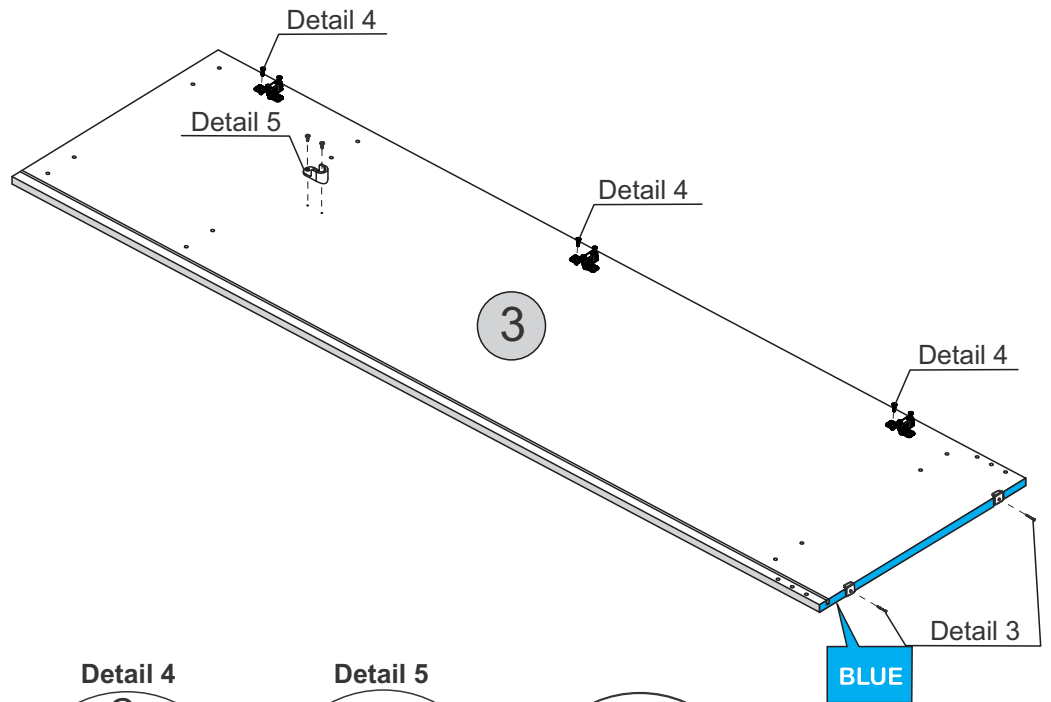
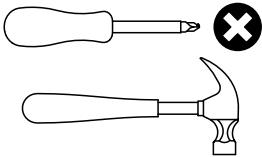

# STEP 8

## PARTS REQUIRED

7 - LEFT SIDE PANEL - RED x1

## HARDWARE REQUIRED

C  08  
Ø4,0 x 14mm

H  02

L  02

M  01

P  03

## TOOLS REQUIRED

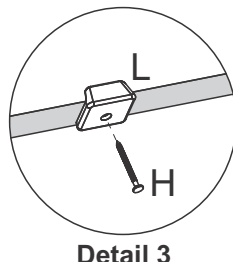
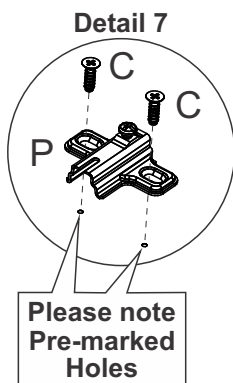
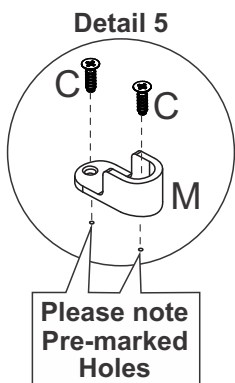
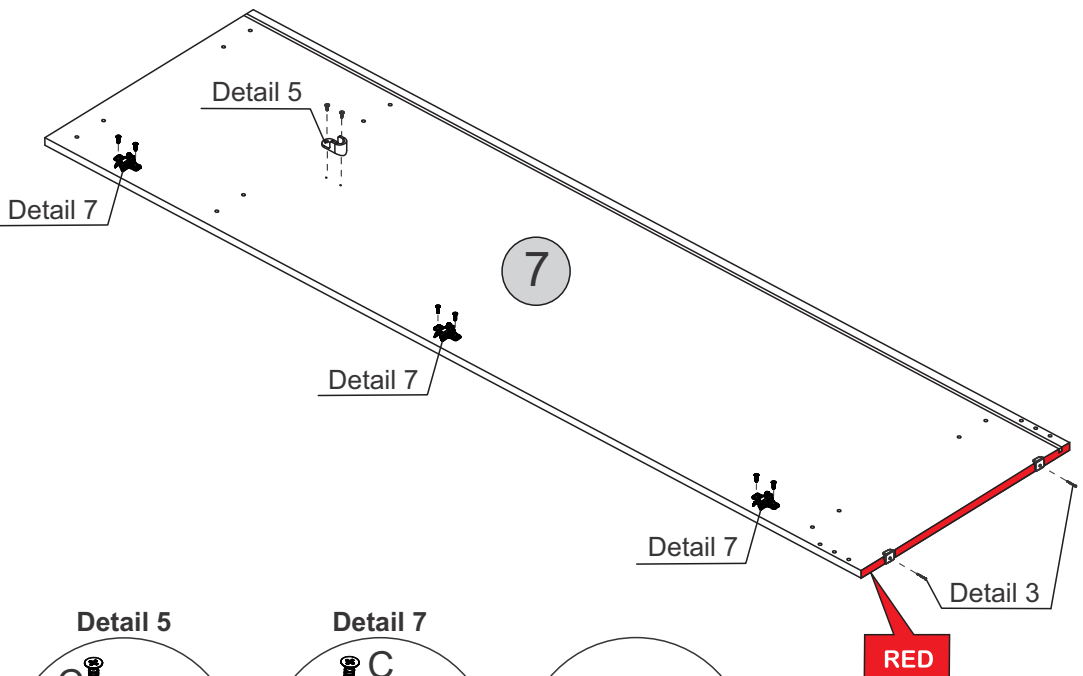
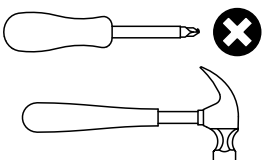



# STEP 9

## PARTS REQUIRED

9 - TOP PANEL - GREEN x1

## HARDWARE REQUIRED

G  04  
Ø6,0 x 30mm

V  01  
Glue

Z  06  
Ø4,0 x 12mm

I  03

## TOOLS REQUIRED

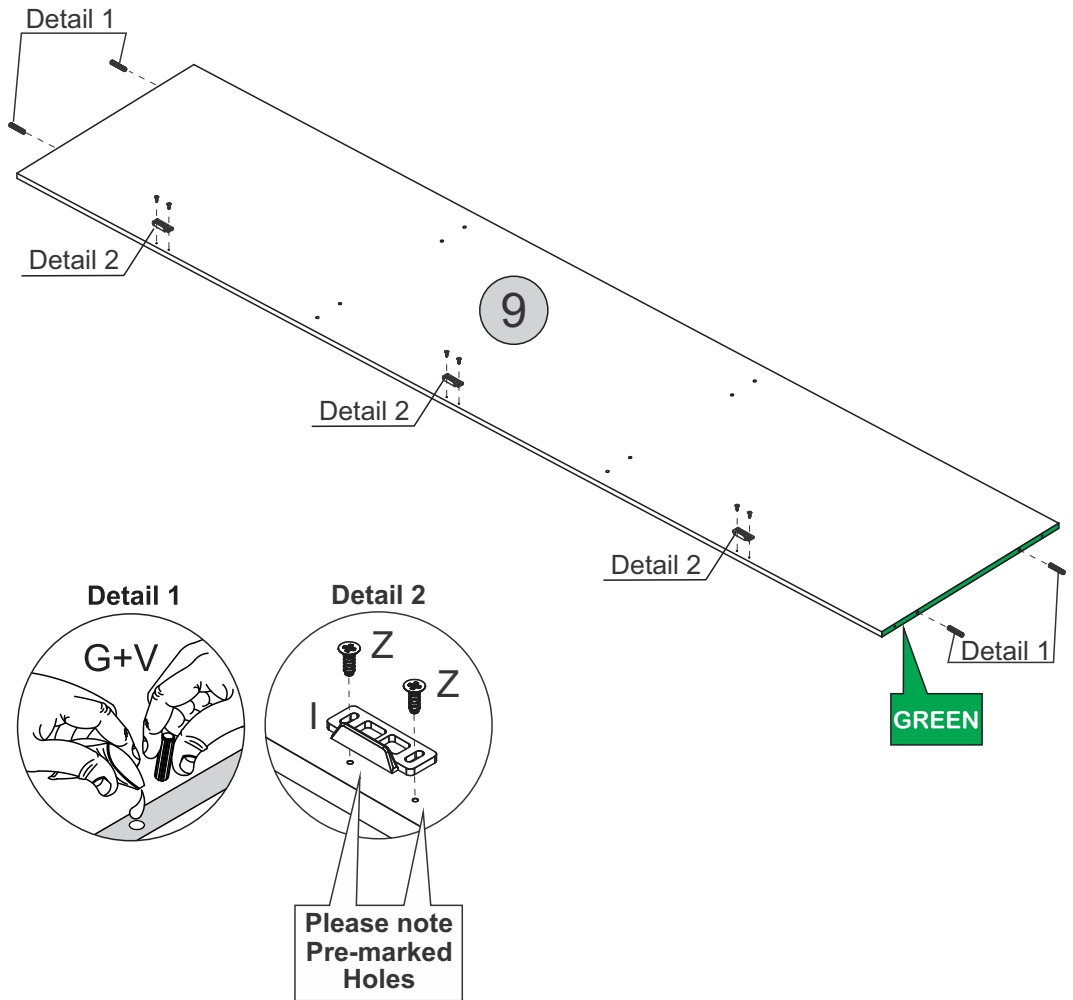
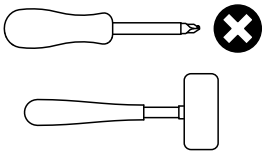



# STEP 10

## PARTS REQUIRED

9 - TOP PANEL - GREEN x1

## HARDWARE REQUIRED

J  05

Z  05  
Ø4,0 x 12mm

## TOOLS REQUIRED

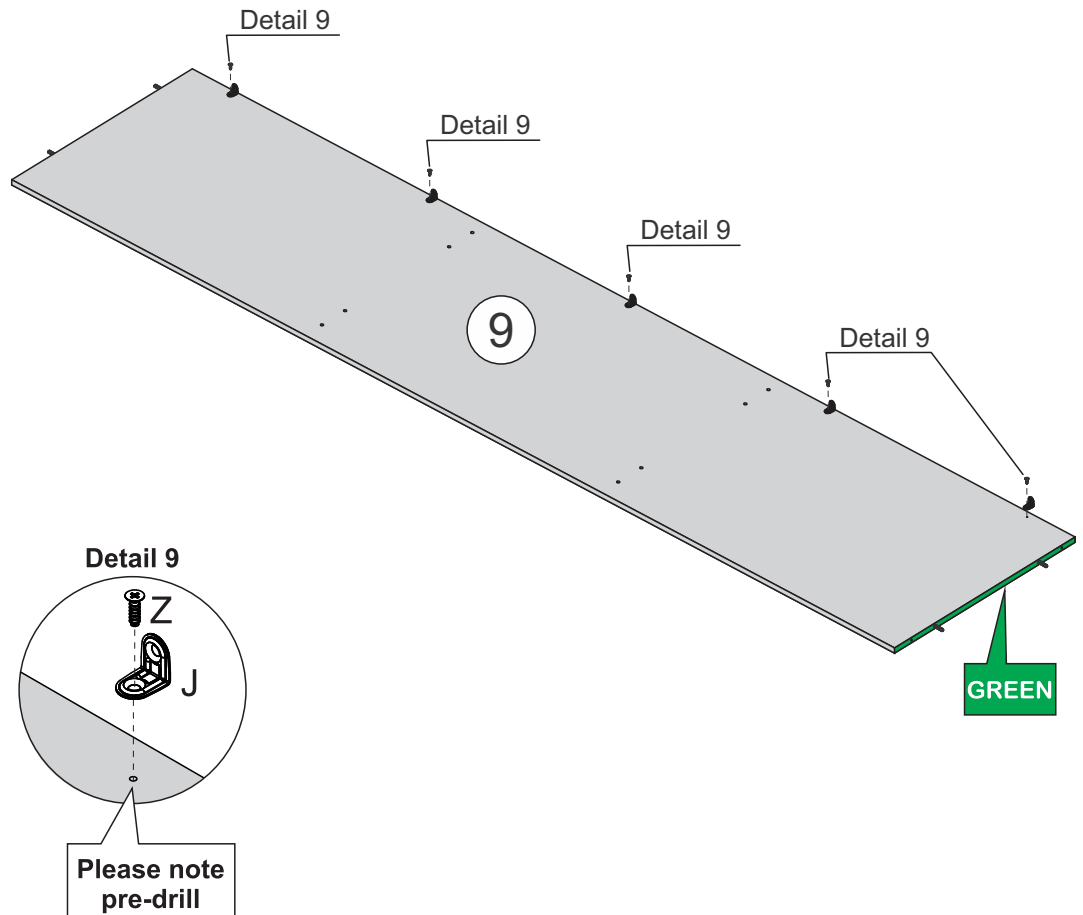
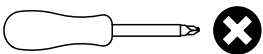



# STEP 11

## PARTS REQUIRED

21 - CENTRAL BASEBOARD - RED x2

## HARDWARE REQUIRED

G  08  
Ø6,0 x 30mm

J  04

V  01  
Glue

Z  04  
Ø4,0 x 12mm

## TOOLS REQUIRED

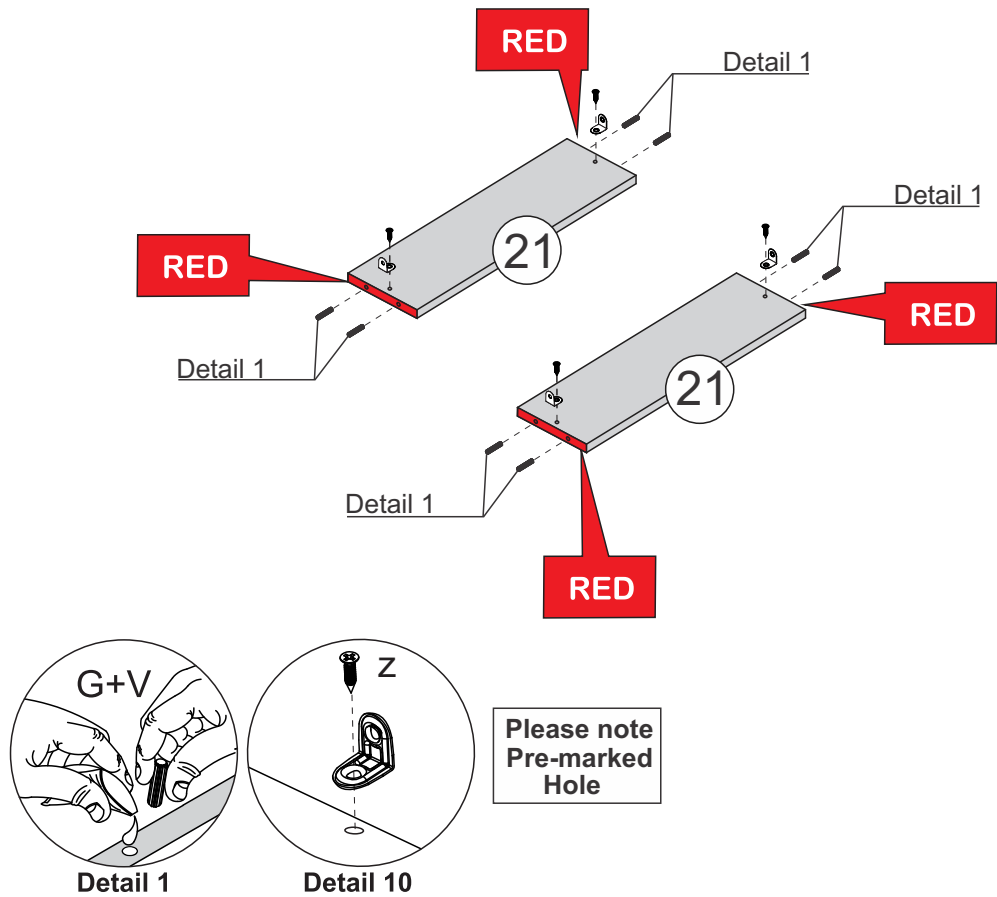
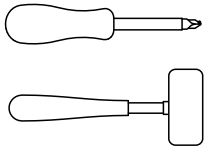

# STEP 12

## PARTS REQUIRED

6 - BACK BASEBOARD - BLACK x1

8 - FRONT BASEBOARD - GREEN x1

21 - CENTRAL BASEBOARD - RED x2

## HARDWARE REQUIRED

V  01  
Glue

Z  04  
Ø4,0 x 12mm

## TOOLS REQUIRED

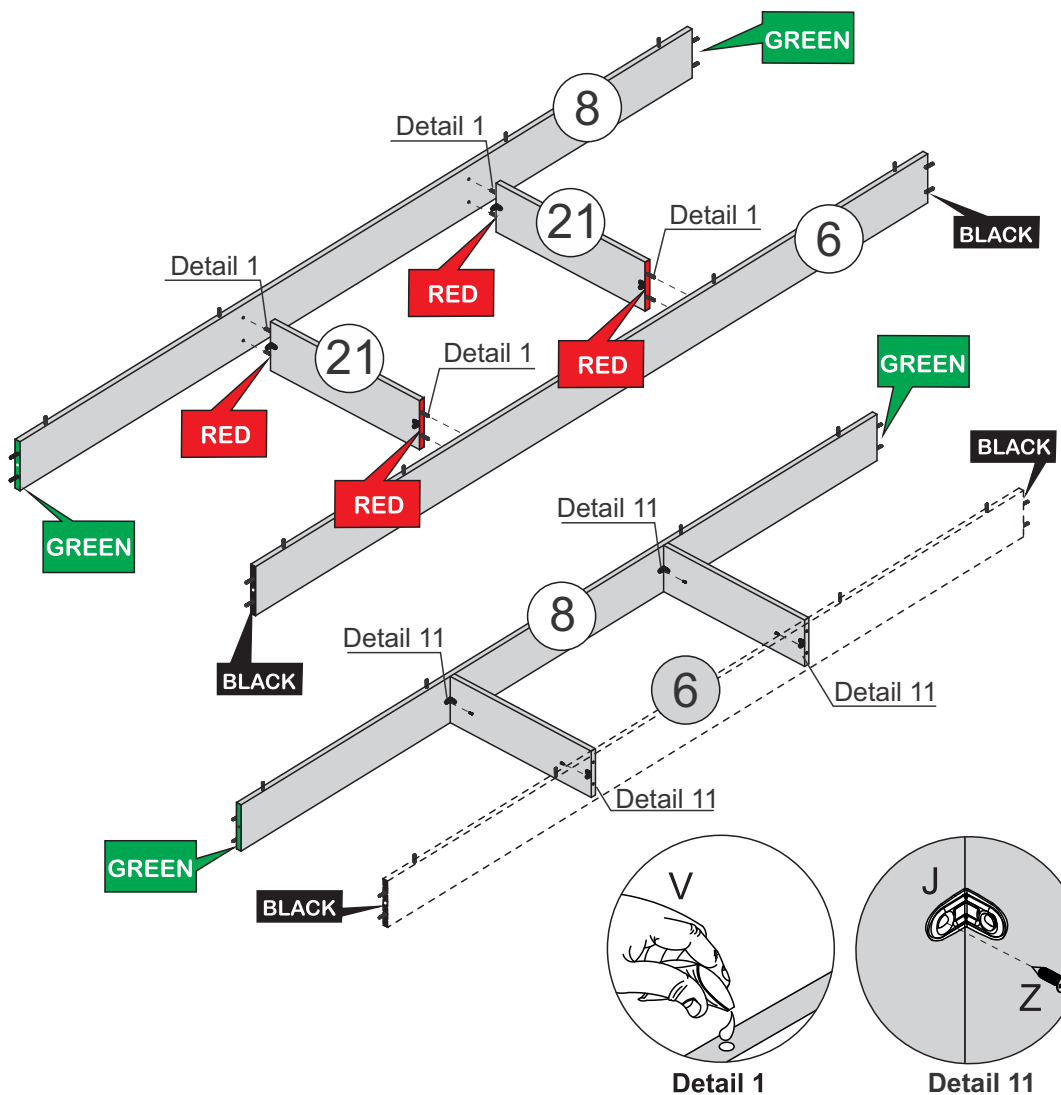
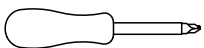

# STEP 13

## PARTS REQUIRED

1 - BASE PANEL - BLACK x2

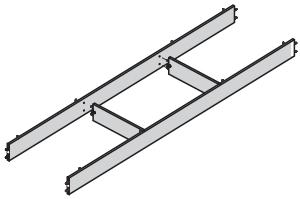

## HARDWARE REQUIRED

## TOOLS REQUIRED

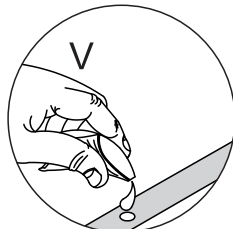
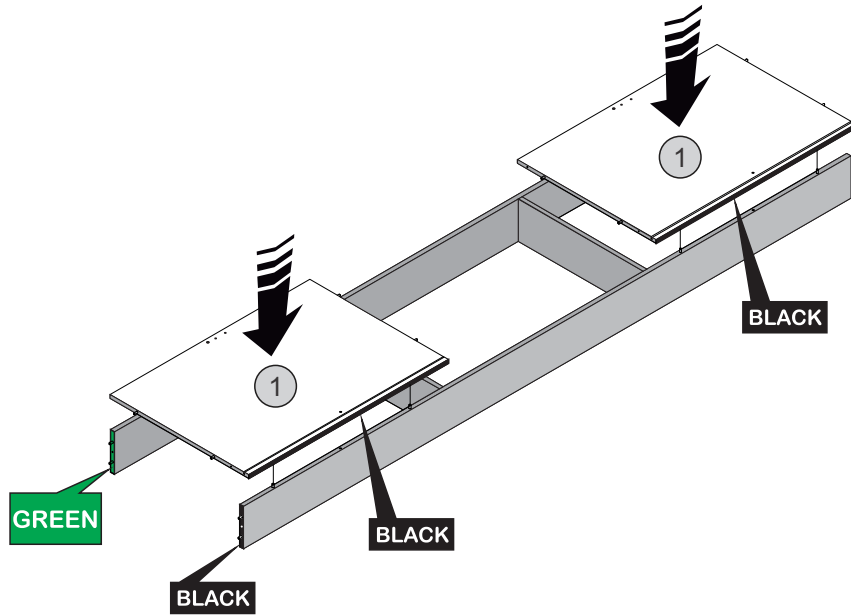

Detail 1

# STEP 14

## PARTS REQUIRED

7 - LEFT SIDE PANEL - RED x1

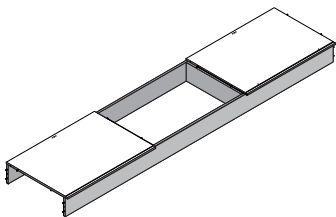

## HARDWARE REQUIRED

F  Ø4,0 x 50mm 04

V  01

## TOOLS REQUIRED

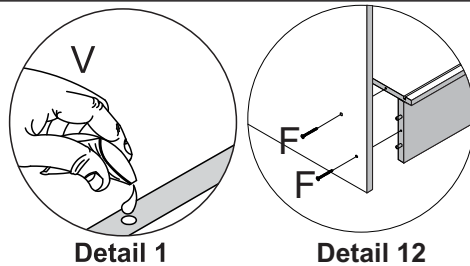
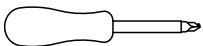

Detail 1

Detail 12

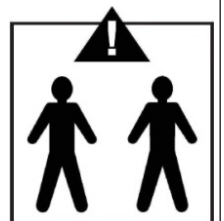
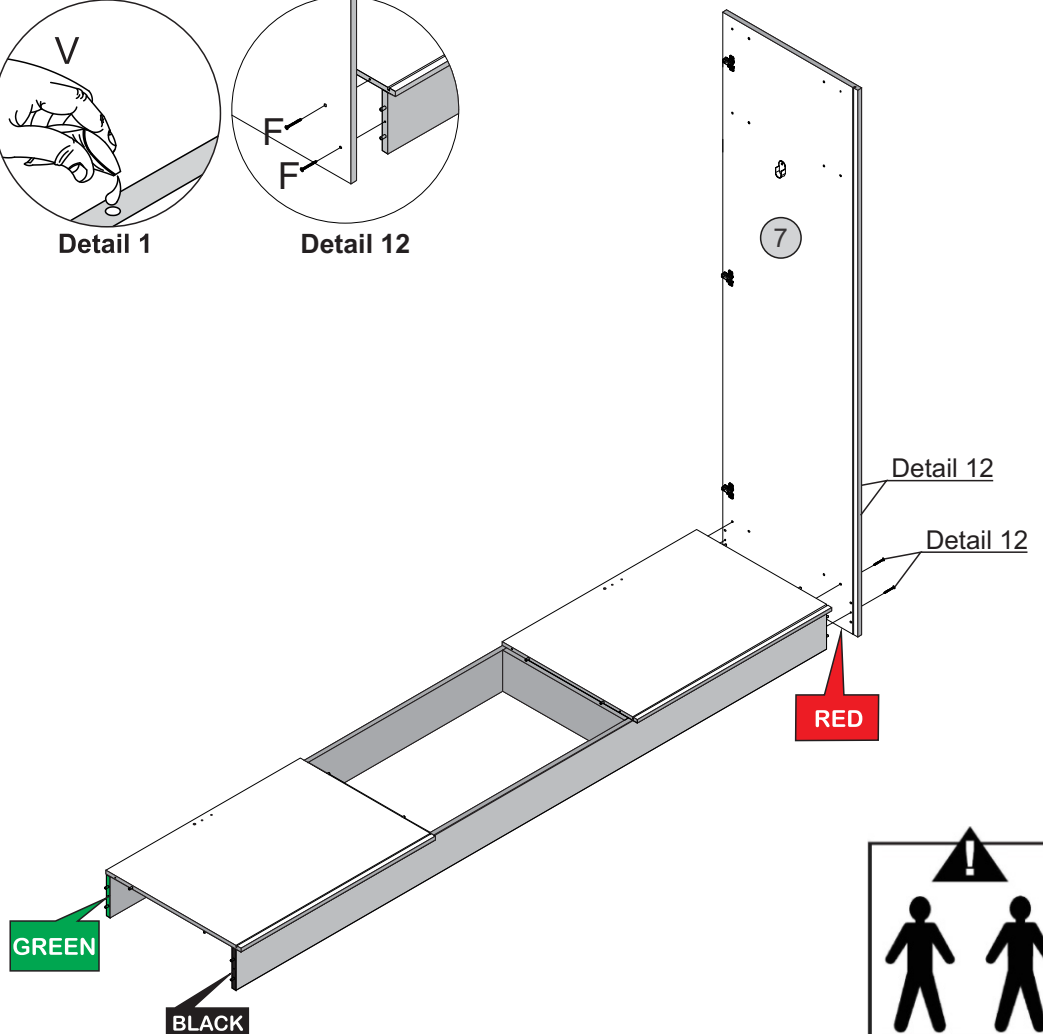

# STEP 15

## PARTS REQUIRED

5 - LEFT DIVISION PANEL - YELLOW x1

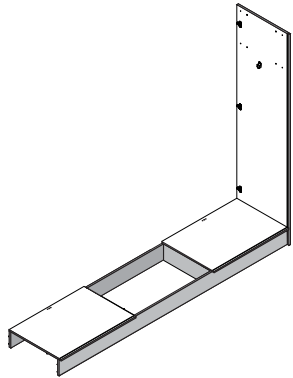

## HARDWARE REQUIRED

F  Ø4,0 x 50mm 02

V  Glue 01

## TOOLS REQUIRED

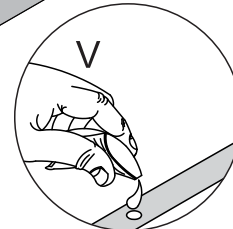
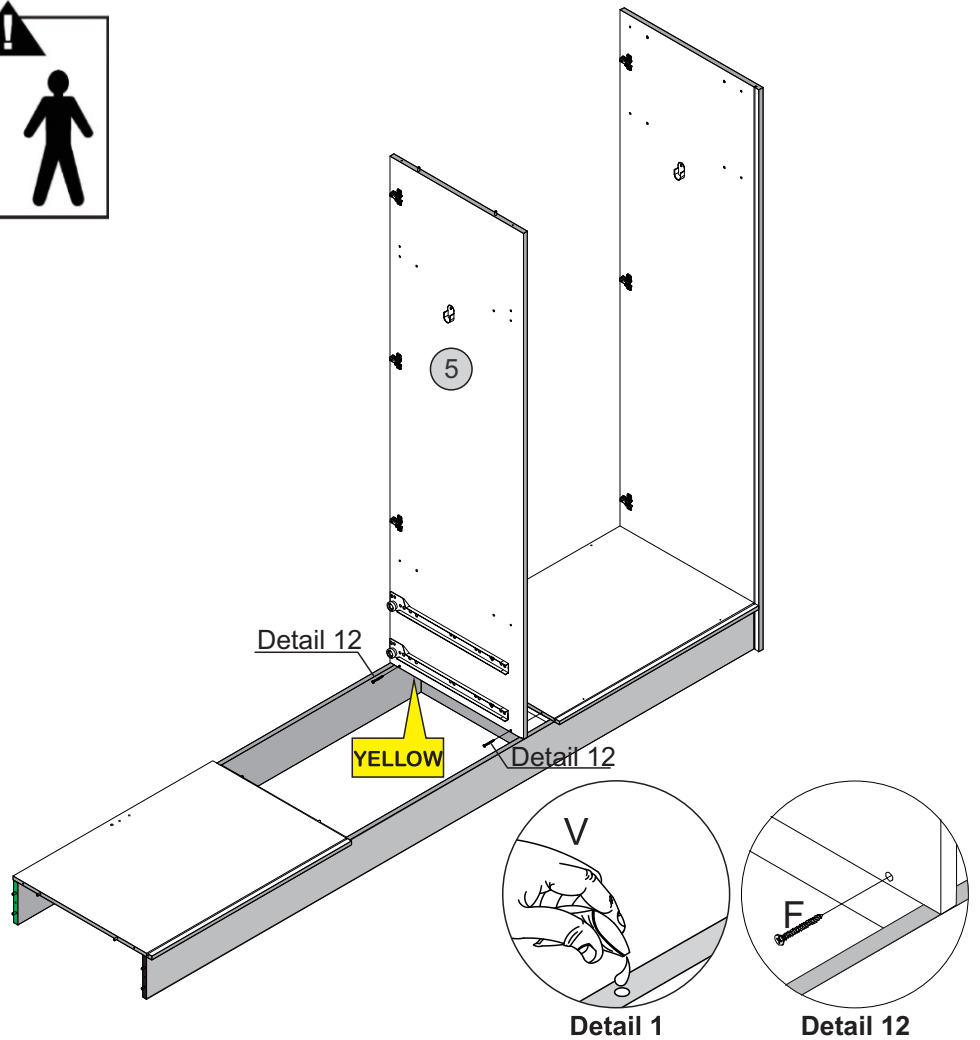
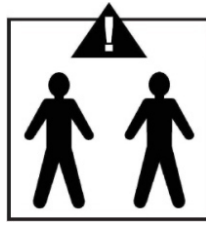

Detail 1

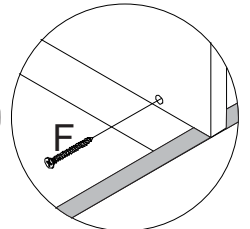

Detail 12

# STEP 16

## PARTS REQUIRED

10 - UPPER PANEL - BLUE x1

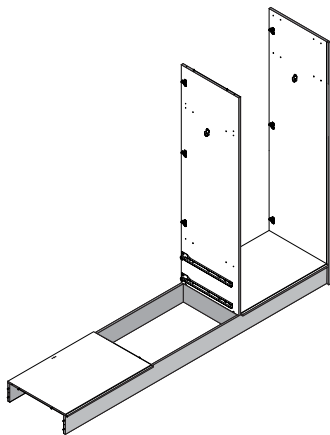

## HARDWARE REQUIRED

F  Ø4,0 x 50mm 04

V  Glue 01

## TOOLS REQUIRED

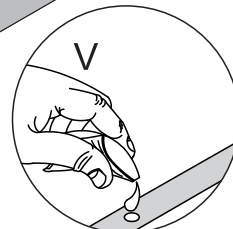
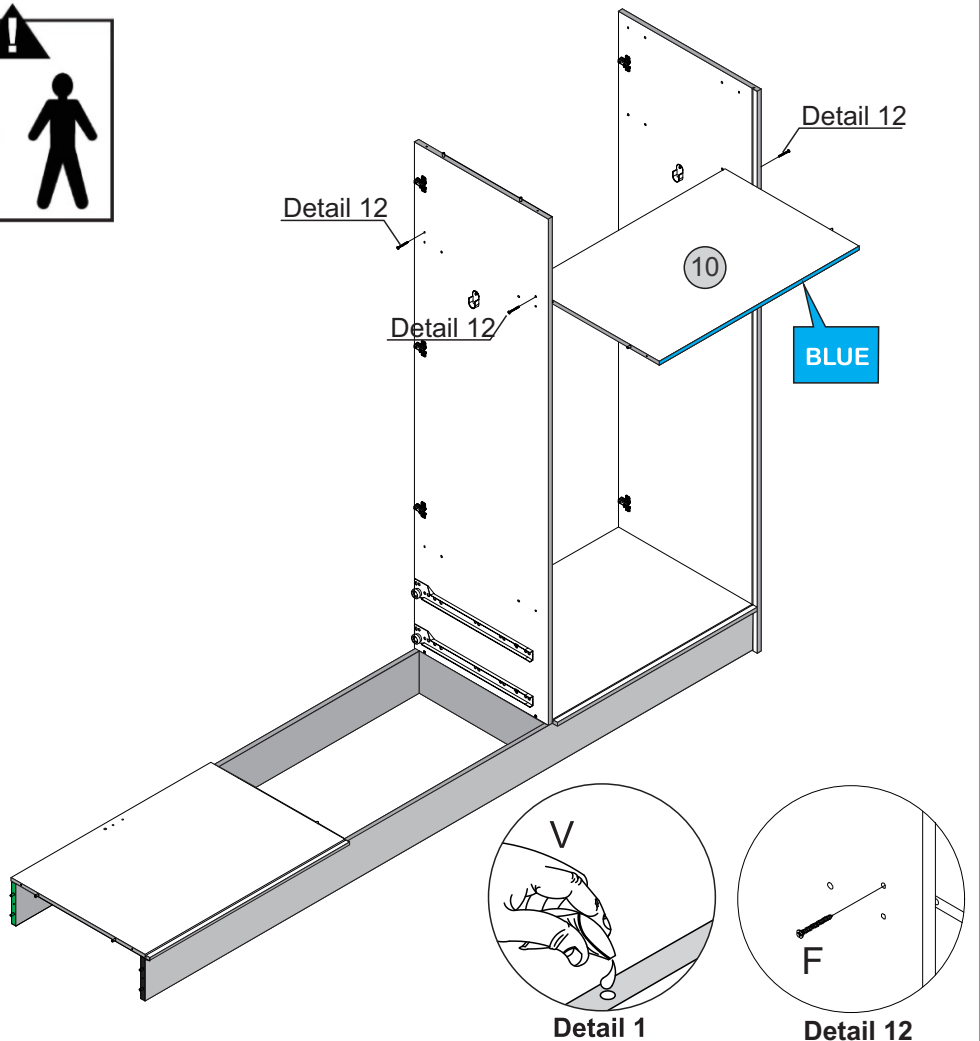
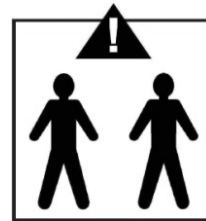

Detail 1

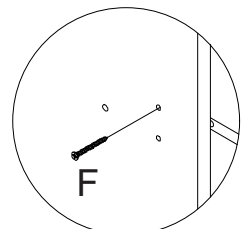

Detail 12

# STEP 17

## PARTS REQUIRED

4 - RIGHT DIVISION PANEL - GREEN x1

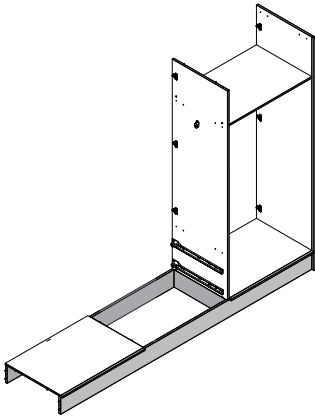

## HARDWARE REQUIRED

F  02  
Ø4.0 x 50mm

V  01

## TOOLS REQUIRED

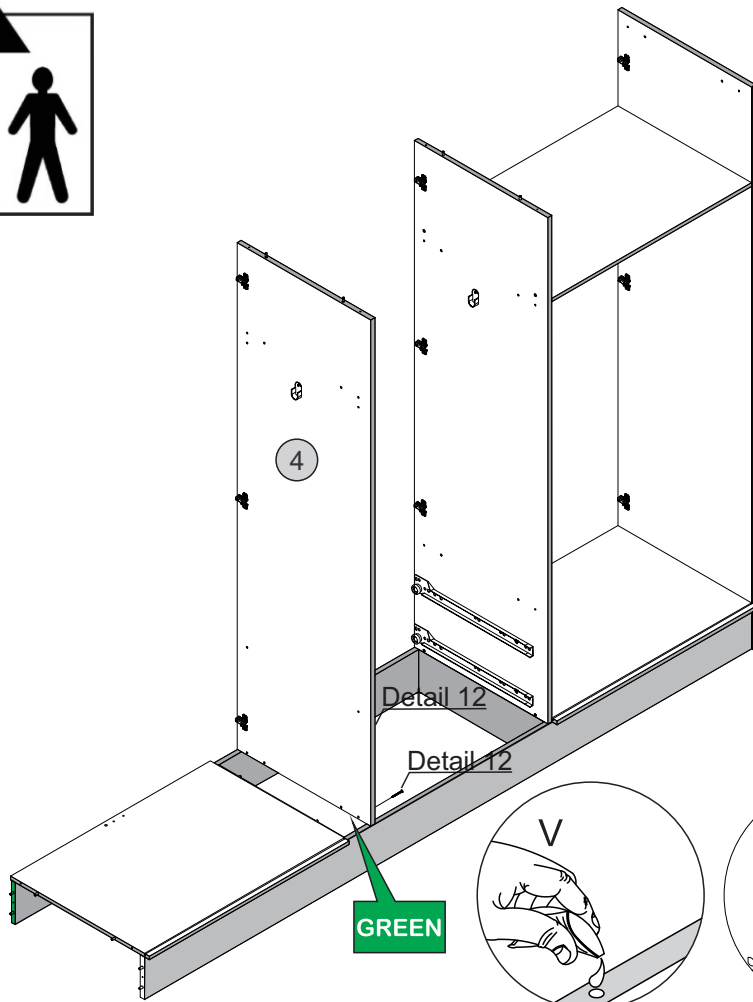
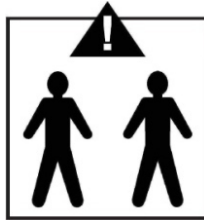
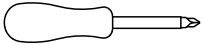

Detail 1

Detail 12

# STEP 18

## PARTS REQUIRED

10 - UPPER PANEL - BLUE x1

23 - SHELF OVER DRAWER - RED x1

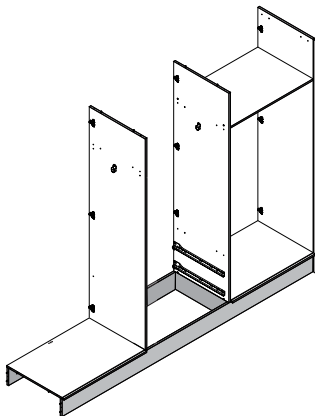

## HARDWARE REQUIRED

F  08  
Ø4.0 x 50mm

V  01

## TOOLS REQUIRED

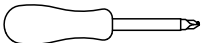

### Attention

First place the shelf over drawer (23 - RED) and then place the Upper Panel (10 - BLUE).

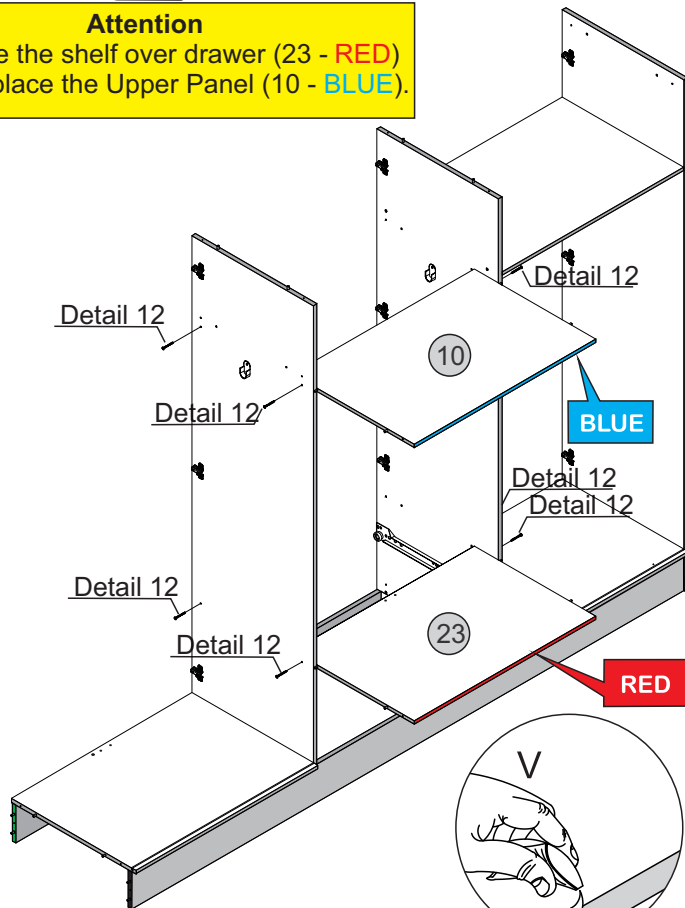
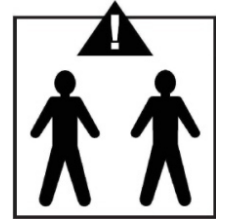

Detail 1

Detail 12

# STEP 19

## PARTS REQUIRED

3 - RIGHT SIDE PANEL - BLUE x1

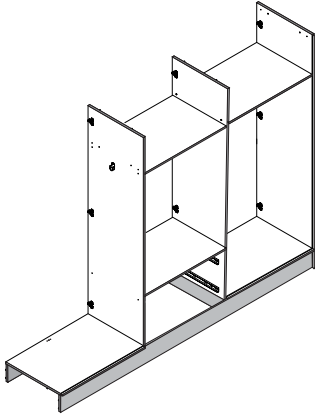

## HARDWARE REQUIRED

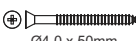
F  04  
Ø4,0 x 50mm

V  01

## TOOLS REQUIRED

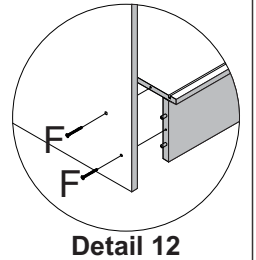
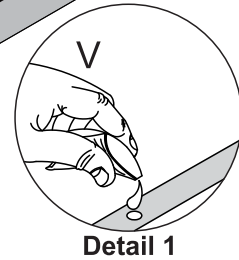
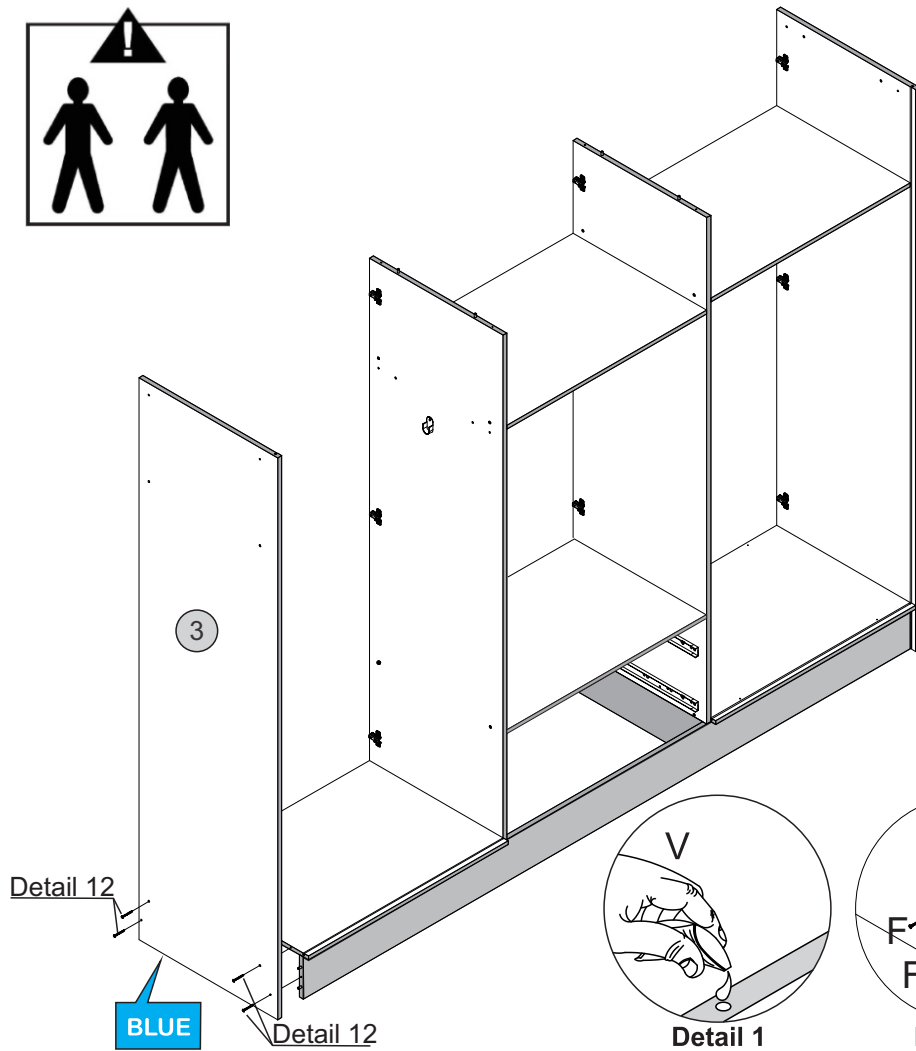
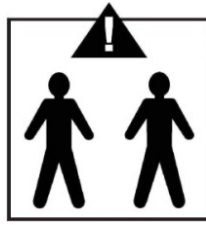
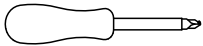

# STEP 20

## PARTS REQUIRED

10 - UPPER PANEL - BLUE x1

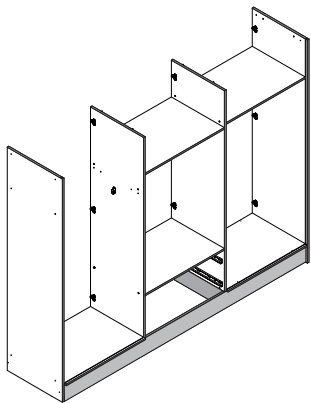

## HARDWARE REQUIRED

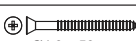
F  04  
Ø4,0 x 50mm

V  01

## TOOLS REQUIRED

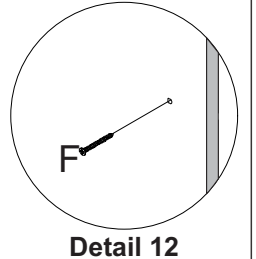
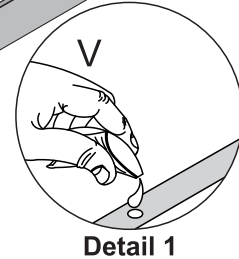
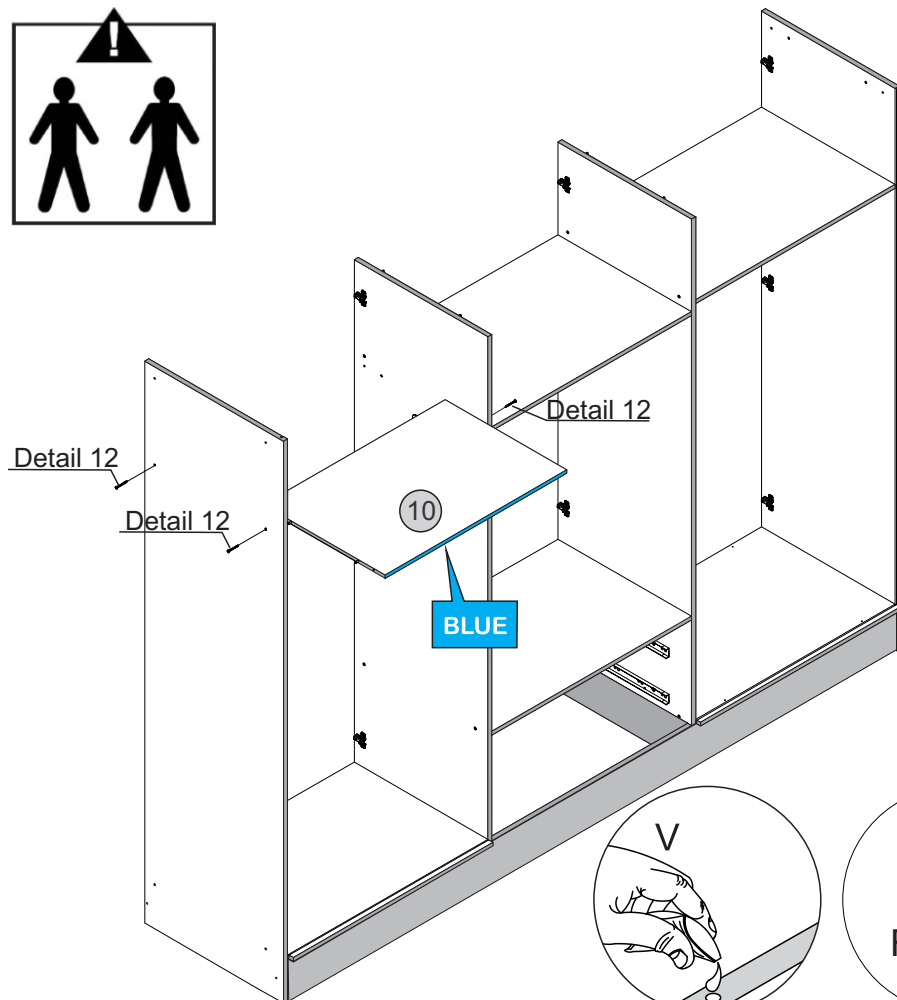
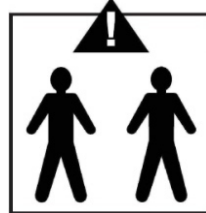

# STEP 21

## PARTS REQUIRED

9 - TOP PANEL - GREEN x1

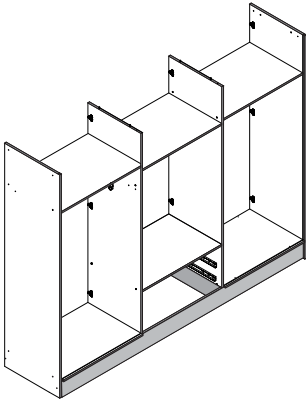

## HARDWARE REQUIRED

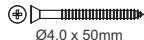
F  12  
Ø4,0 x 50mm

V  01

## TOOLS REQUIRED

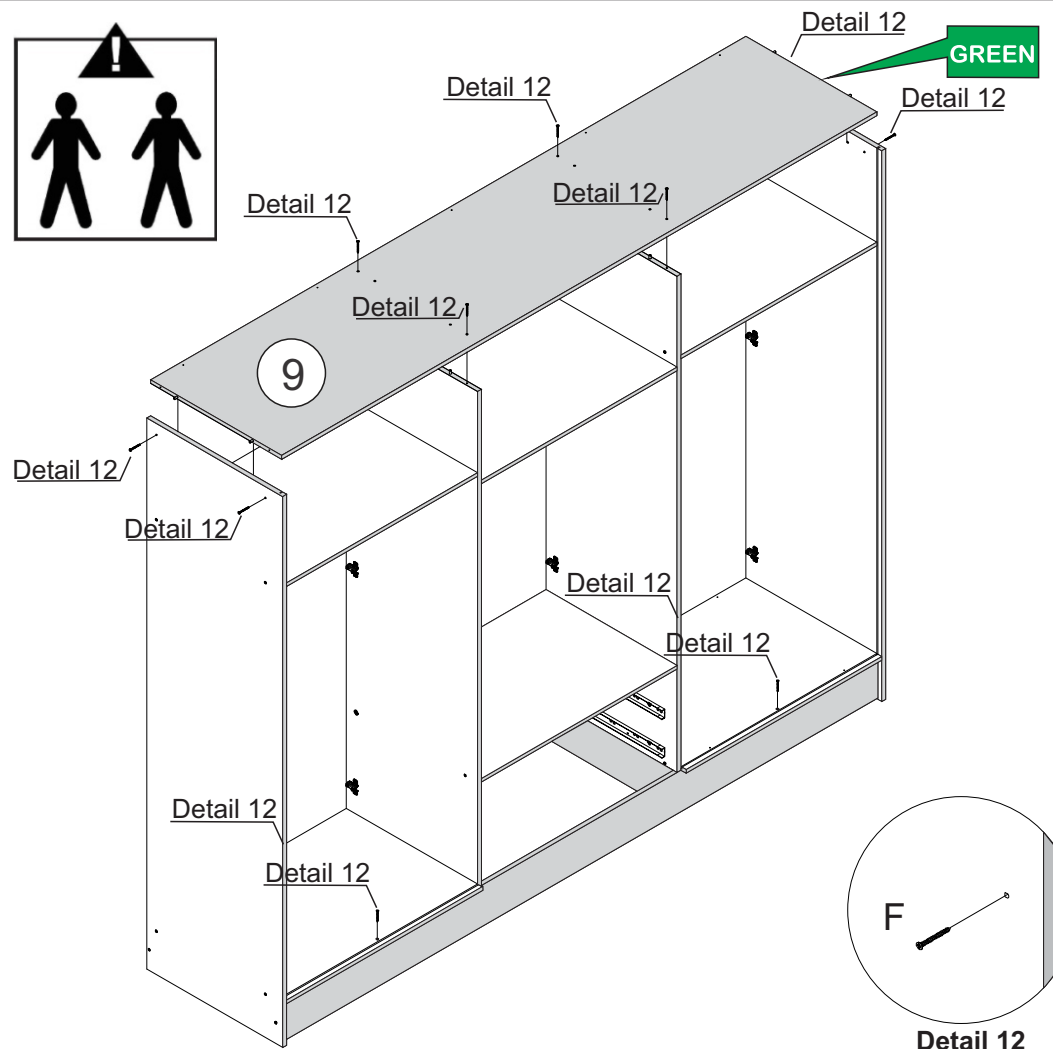
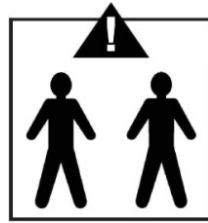
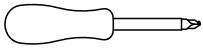

# STEP 22

## PARTS REQUIRED

20 -BACK PANEL x2

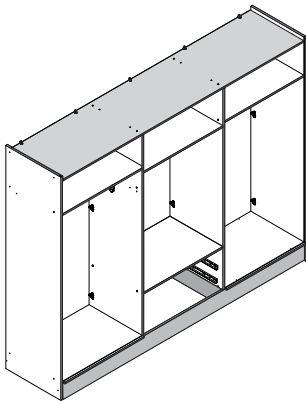

## HARDWARE REQUIRED

H  06  
10 x 10

## TOOLS REQUIRED

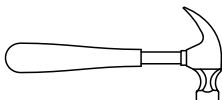

### IMPORTANT PLEASE FOLLOW !

Please make sure the top of Part 20 is lined up straight with Part 9 as this can affect the alignment of the doors once assembled.

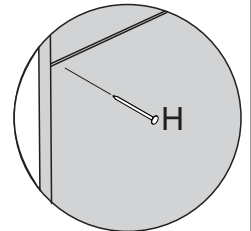
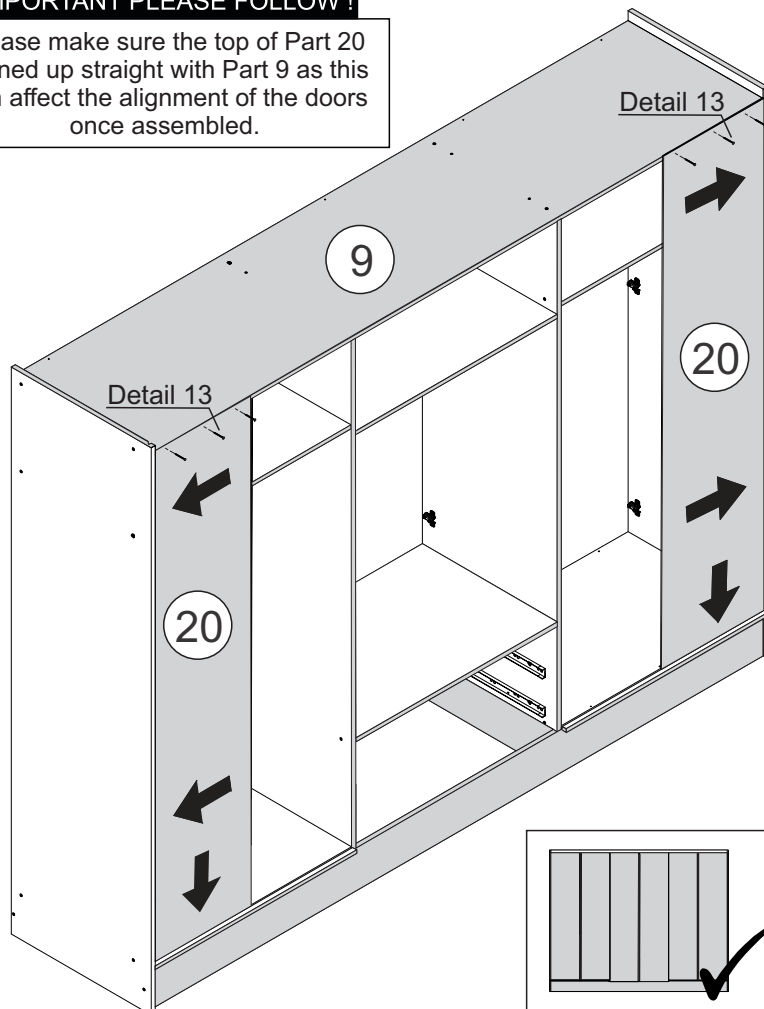

Detail 13

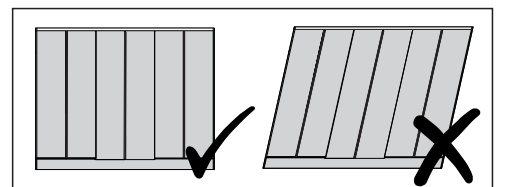
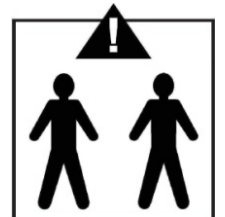

# STEP 23

## PARTS REQUIRED

20 - BACK PANEL x2

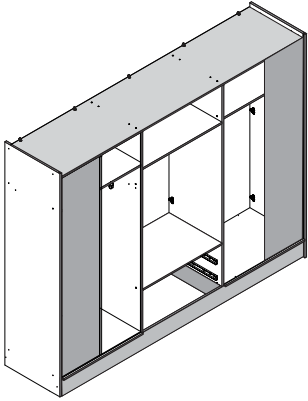

## HARDWARE REQUIRED

H  06  
10 x 10

R  02

## TOOLS REQUIRED

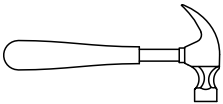

### IMPORTANT PLEASE FOLLOW !

Please make sure the top of Part 20 is lined up straight with Part 9 as this can affect the alignment of the doors once assembled.

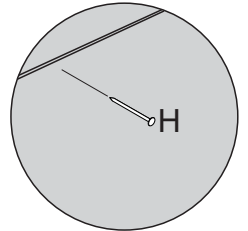
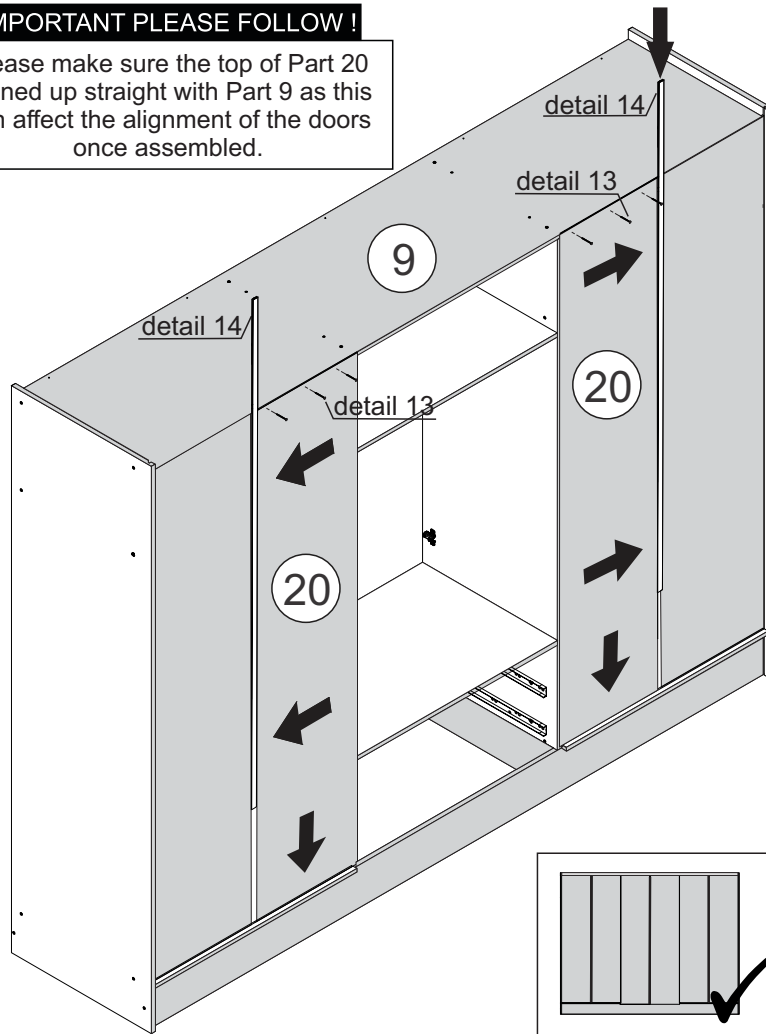

Detail 13

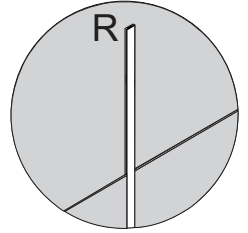

Detail 14

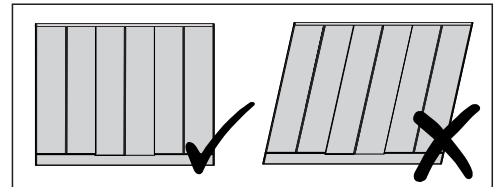
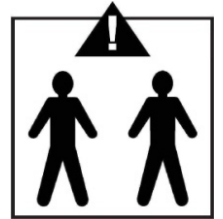

# STEP 24

## PARTS REQUIRED

22 - CENTRE BACK PANEL x2

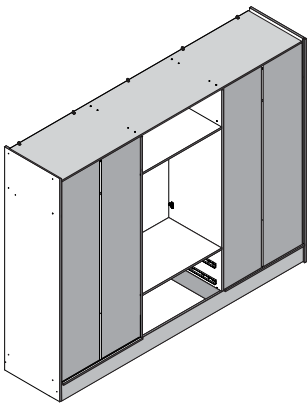

## HARDWARE REQUIRED

H  22  
10 x 10

R  01

A1  16

## TOOLS REQUIRED

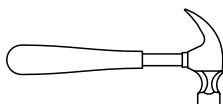

### IMPORTANT PLEASE FOLLOW !

Please make sure the top of Part 22 is lined up straight with Part 9 as this can affect the alignment of the doors once assembled.

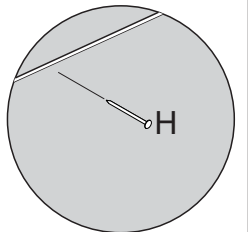
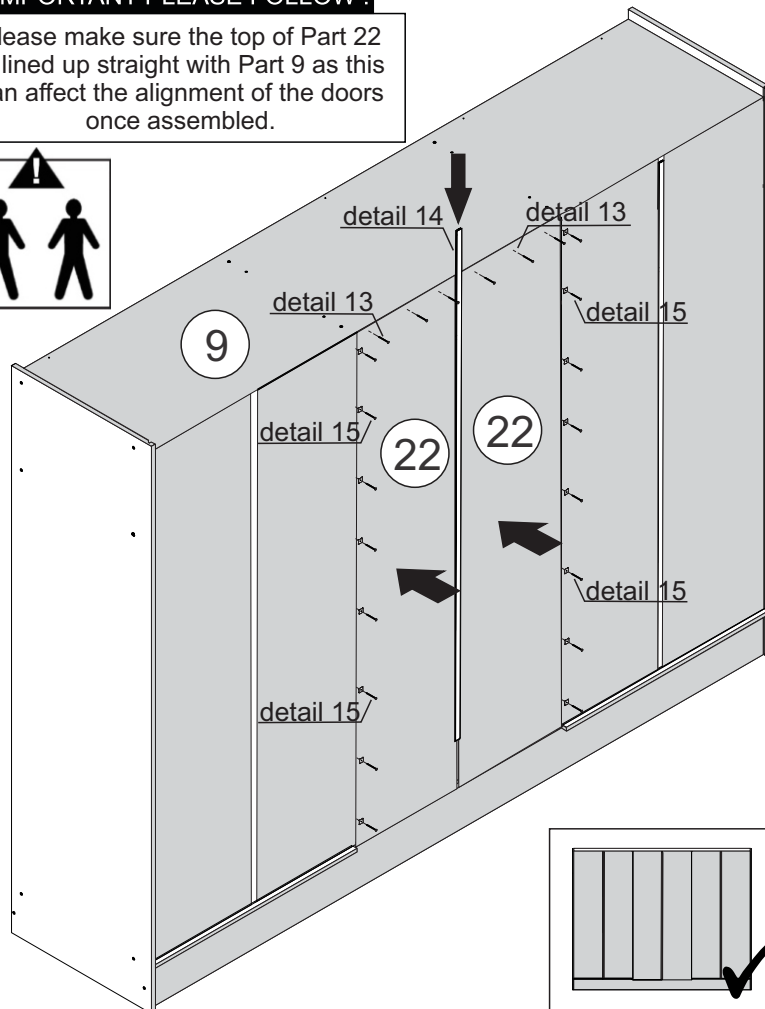

Detail 13

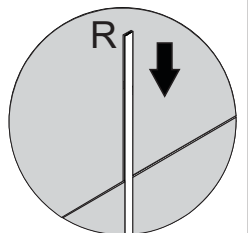

Detail 14

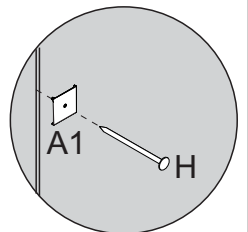

Detail 15

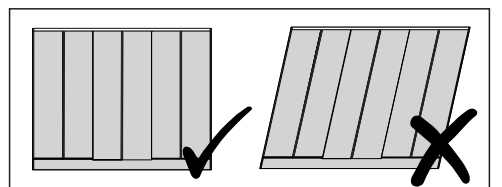



# STEP 25

## PARTS REQUIRED

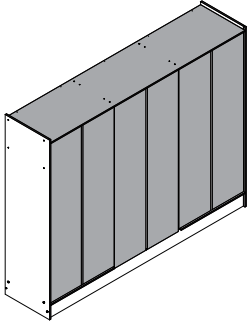

## HARDWARE REQUIRED

B		12
C1	Ø3.5 x 16mm	12
H	10 x 10	06

## TOOLS REQUIRED

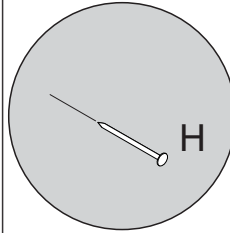
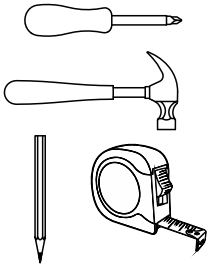

Detail 13

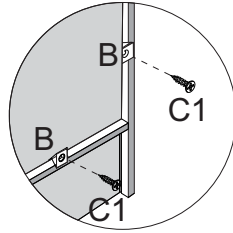

Detail 16

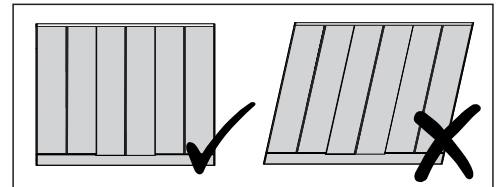
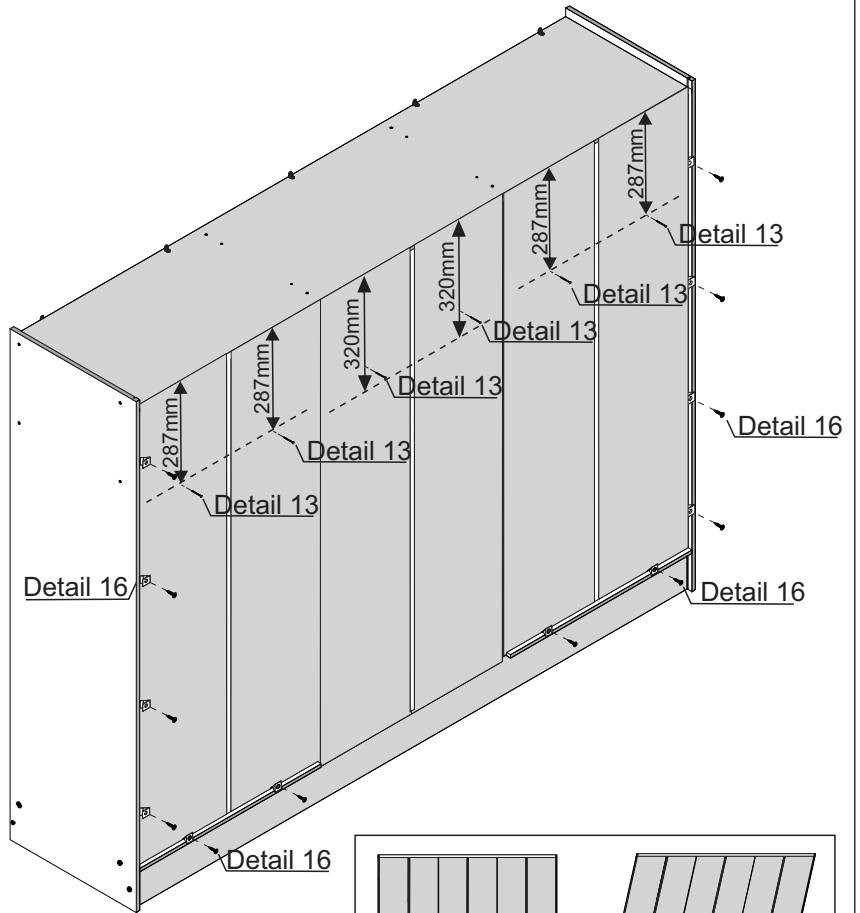

# STEP 26

## PARTS REQUIRED

2 - FRAME	x1
-----------	----

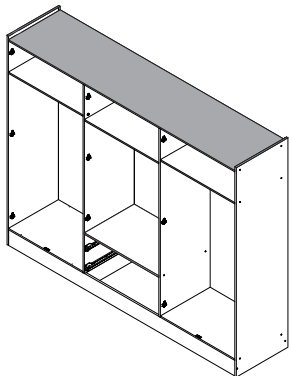

## HARDWARE REQUIRED

H	10 x 10	02
J		02
Z	Ø4,0 x 12mm	09
B1	Ø3.5 x 14mm	06

## TOOLS REQUIRED

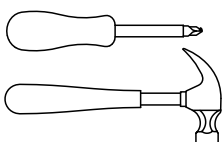

\* For your future reference Order Number should be here

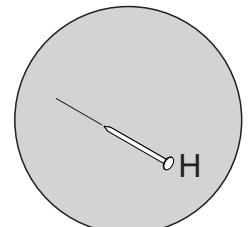
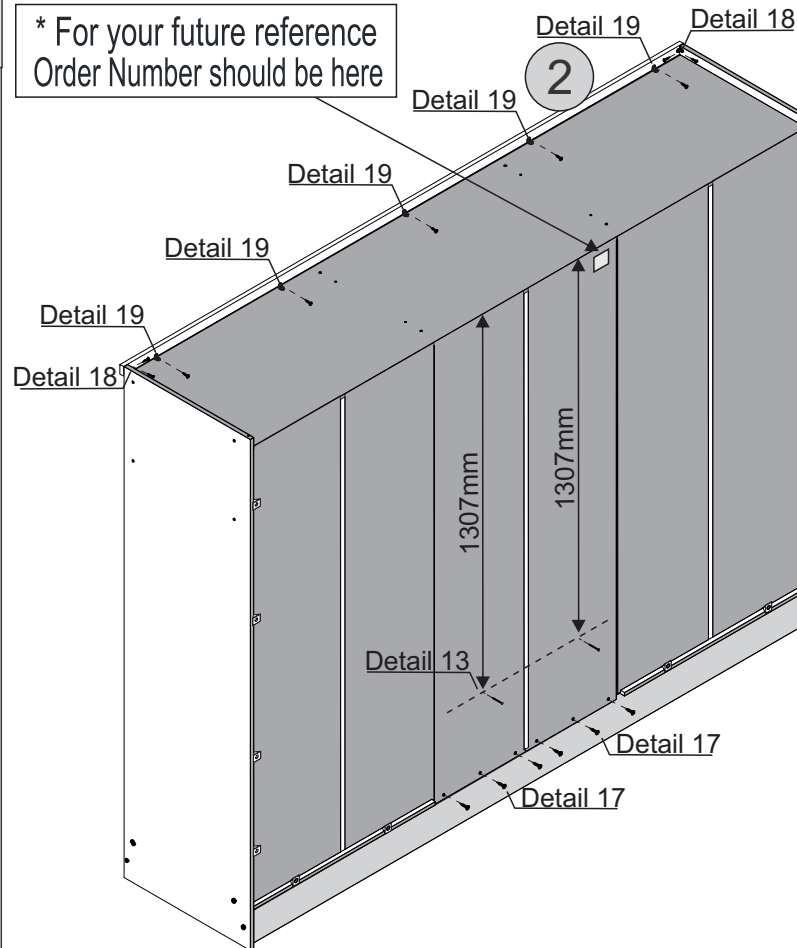

Detail 13

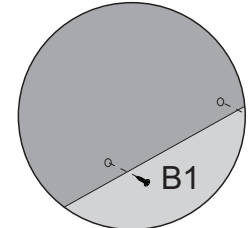

Detail 17

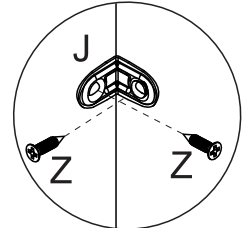

Detail 18

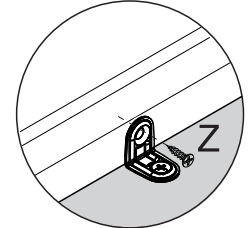



Detail 19

# STEP 27

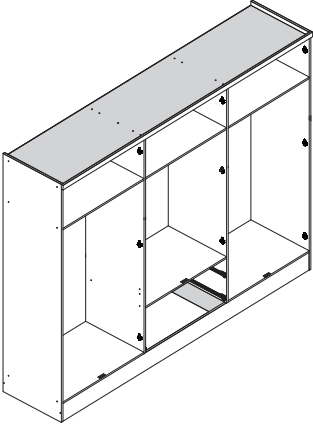
## PARTS REQUIRED



## HARDWARE REQUIRED

I		03
Y		03
Z	 Ø4,0 x 12mm	06

## TOOLS REQUIRED

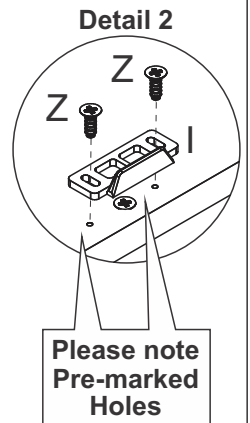
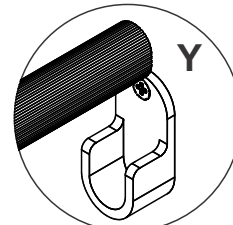
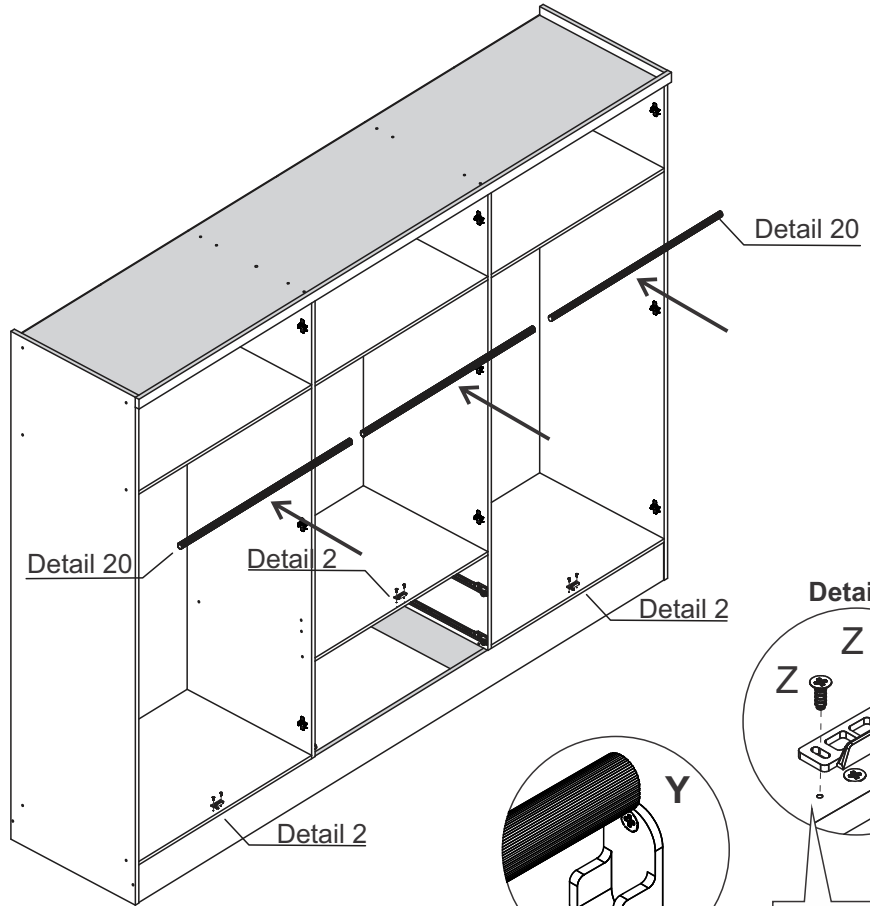
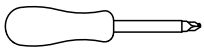

Please note  
Pre-marked  
Holes



Detail 20

# STEP 28

## PARTS REQUIRED

15 - DRAWER SIDE - BLUE	x4
16 - DRAWER BACK PANEL - RED	x2
19 - DRAWER BOTTOM SUPPORTBAR - BLACK	x2

## HARDWARE REQUIRED

G	 Ø6,0 x 30mm	20
V		01

## TOOLS REQUIRED

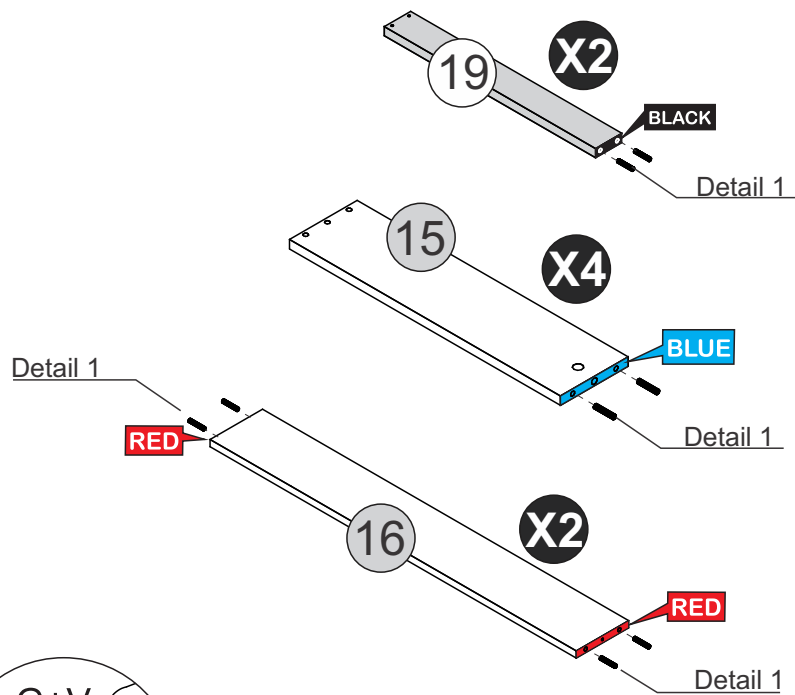
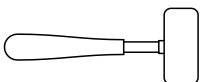

Detail 1

# STEP 29

## PARTS REQUIRED

17 - DRAWER FRONT x2

## HARDWARE REQUIRED

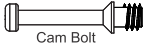
X  04  
Cam Bolt

## TOOLS REQUIRED

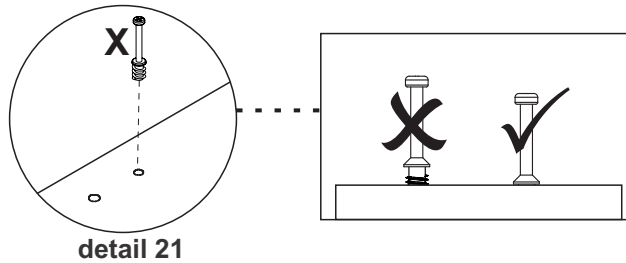
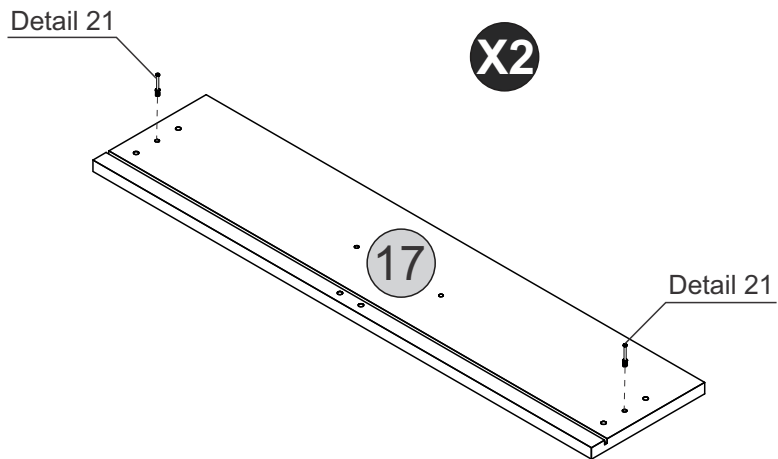
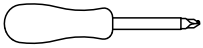

# STEP 30

## PARTS REQUIRED

15 - DRAWER SIDE - BLUE x4

16 - DRAWER BACK PANEL - RED x2

## HARDWARE REQUIRED

F  04  
Ø4,0 x 50mm

## TOOLS REQUIRED

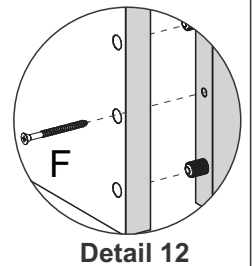
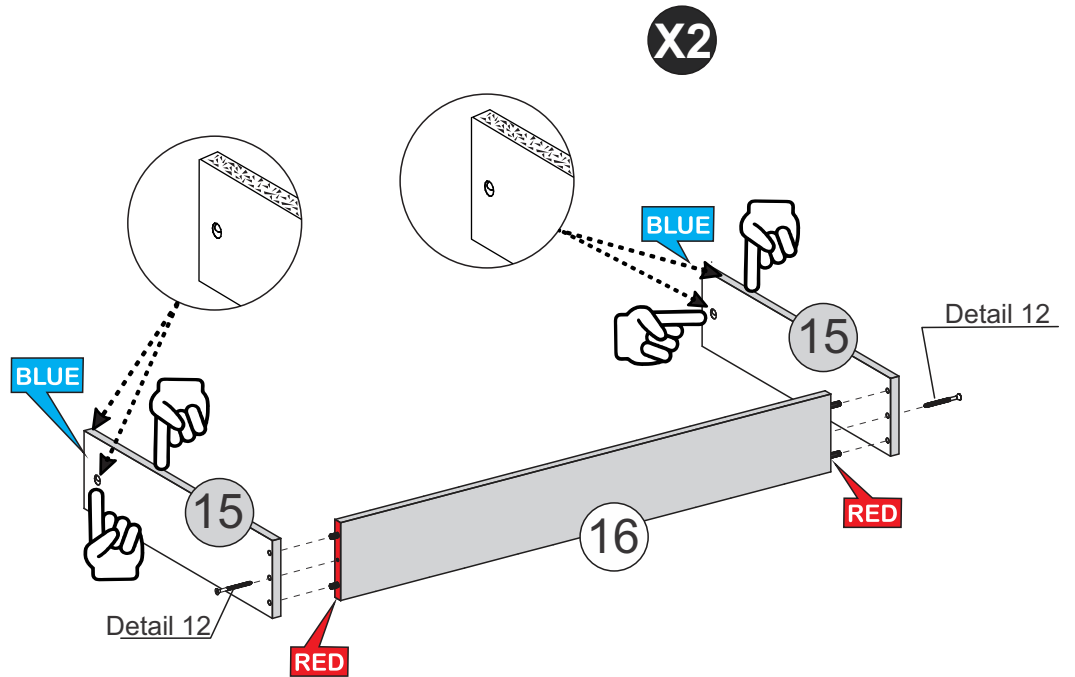

# STEP 31

## PARTS REQUIRED

17 - DRAWER FRONT x2

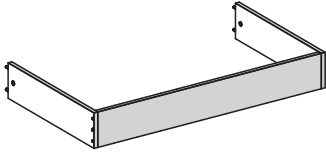

## HARDWARE REQUIRED

U  08

V  01

W  04

## TOOLS REQUIRED

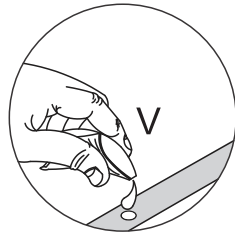
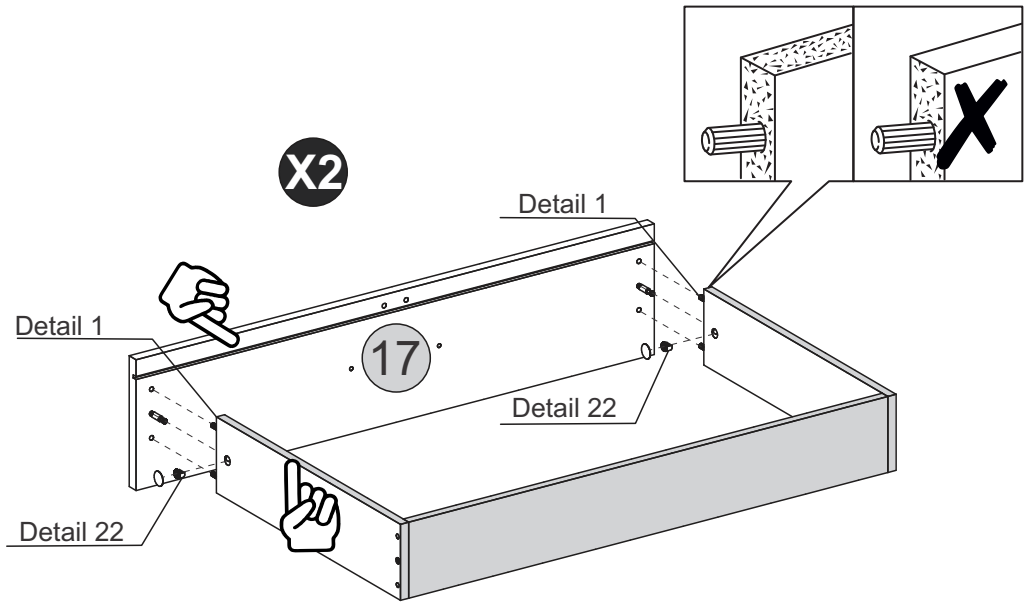
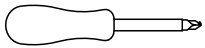

Detail 1

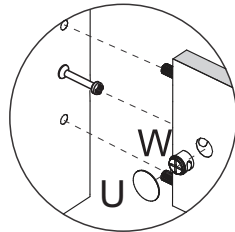

Detail 22

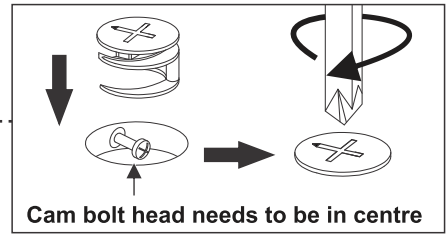

# STEP 32

## PARTS REQUIRED

18 - DRAWER BOTTOM x2

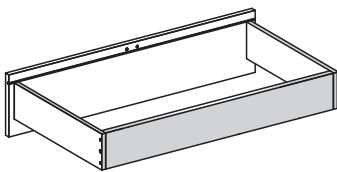

## HARDWARE REQUIRED

H  08

## TOOLS REQUIRED

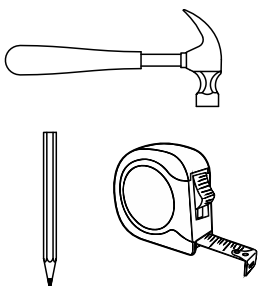

X2

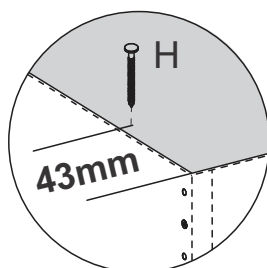
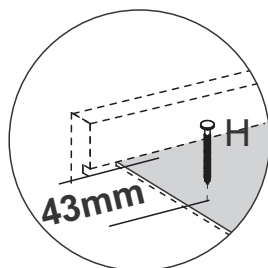
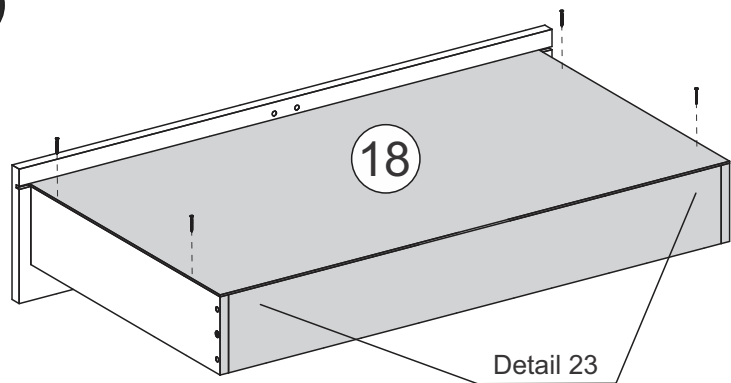

Detail 23

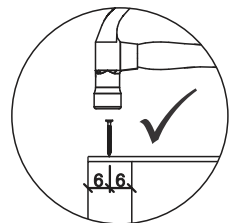
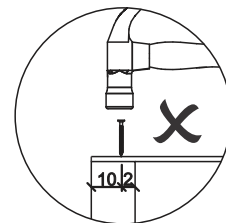
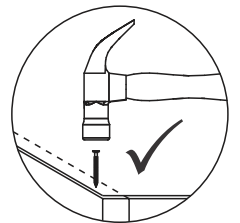
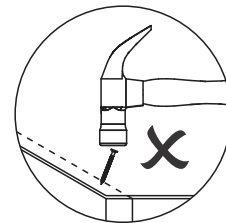

# STEP 33

## PARTS REQUIRED

19 - DRAWER BOTTOM SUPPORTBAR - BLACK X2

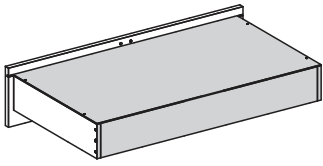

## HARDWARE REQUIRED

E  04  
Ø3,5 x 40mm

H  12  
10 x 10

## TOOLS REQUIRED

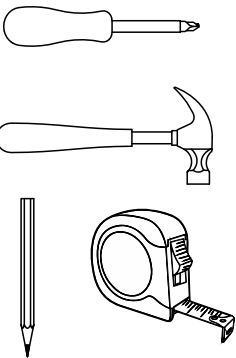

**X2**

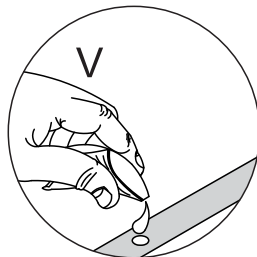
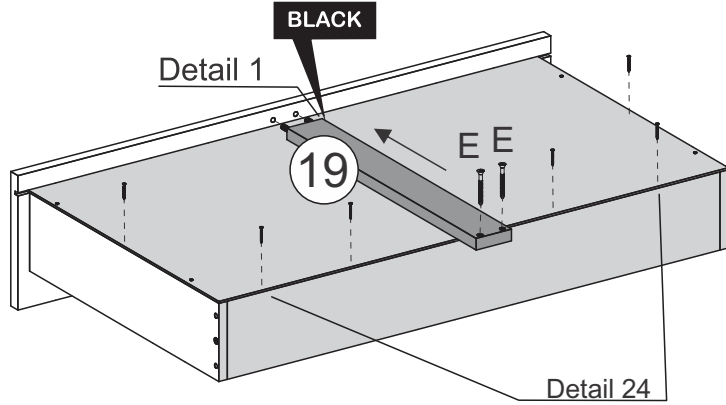

Detail 1

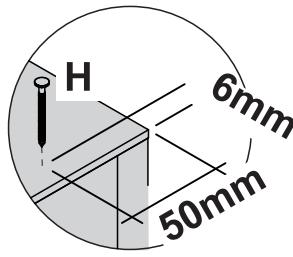

Detail 24

# STEP 34

## PARTS REQUIRED

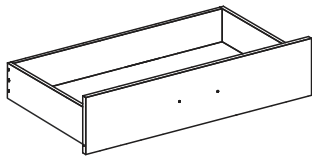

## HARDWARE REQUIRED

C  08  
Ø4,0 x 14mm

D  04  
Ø4,0 x 20mm

Q  04

T  02

## TOOLS REQUIRED

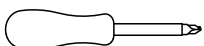

**X2**

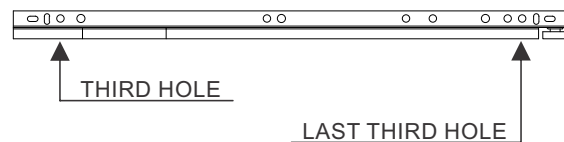
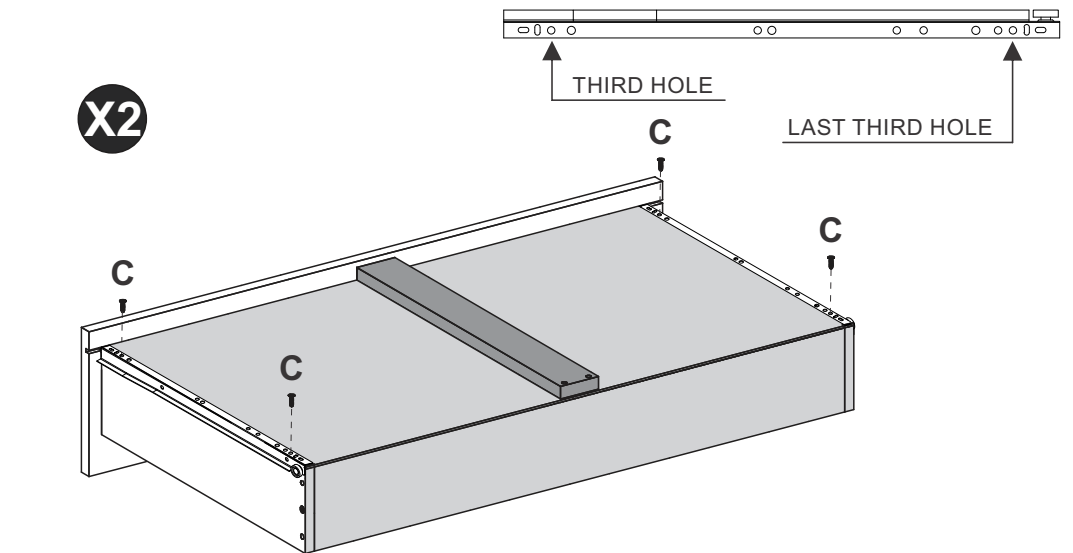

**X2**

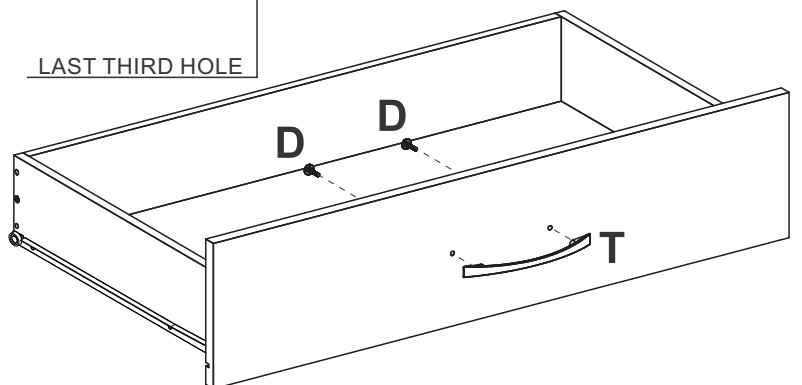



# STEP 35

## PARTS REQUIRED

11 - RIGHT LARGE DOOR	x2
12 - LEFT LARGE DOOR	x2
13 - RIGHT SMALL DOOR	x1
14 - LEFT SMALL DOOR	x1

## HARDWARE REQUIRED

C		36
O		18

## TOOLS REQUIRED

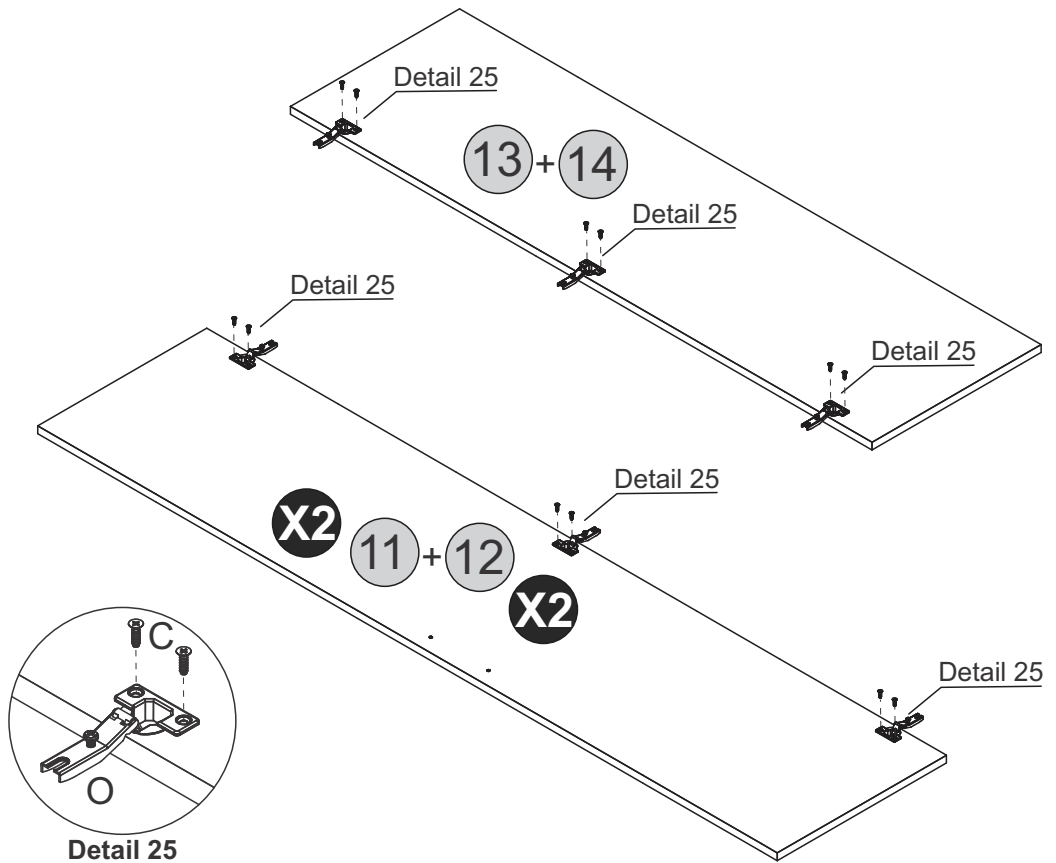
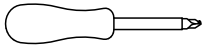

# STEP 36

## PARTS REQUIRED

11 - RIGHT LARGE DOOR	x2
12 - LEFT LARGE DOOR	x2
13 - RIGHT SMALL DOOR	x1
14 - LEFT SMALL DOOR	x1

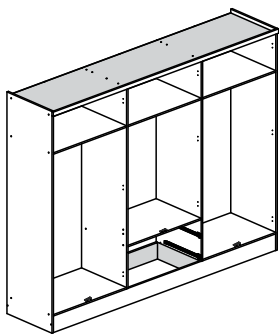

## HARDWARE REQUIRED

U		30
---	---	----

## TOOLS REQUIRED

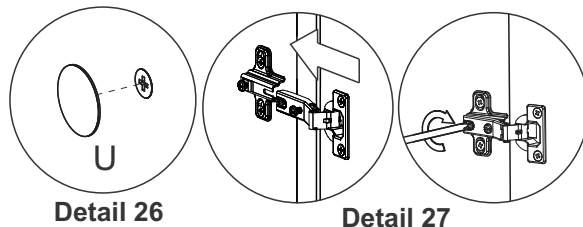
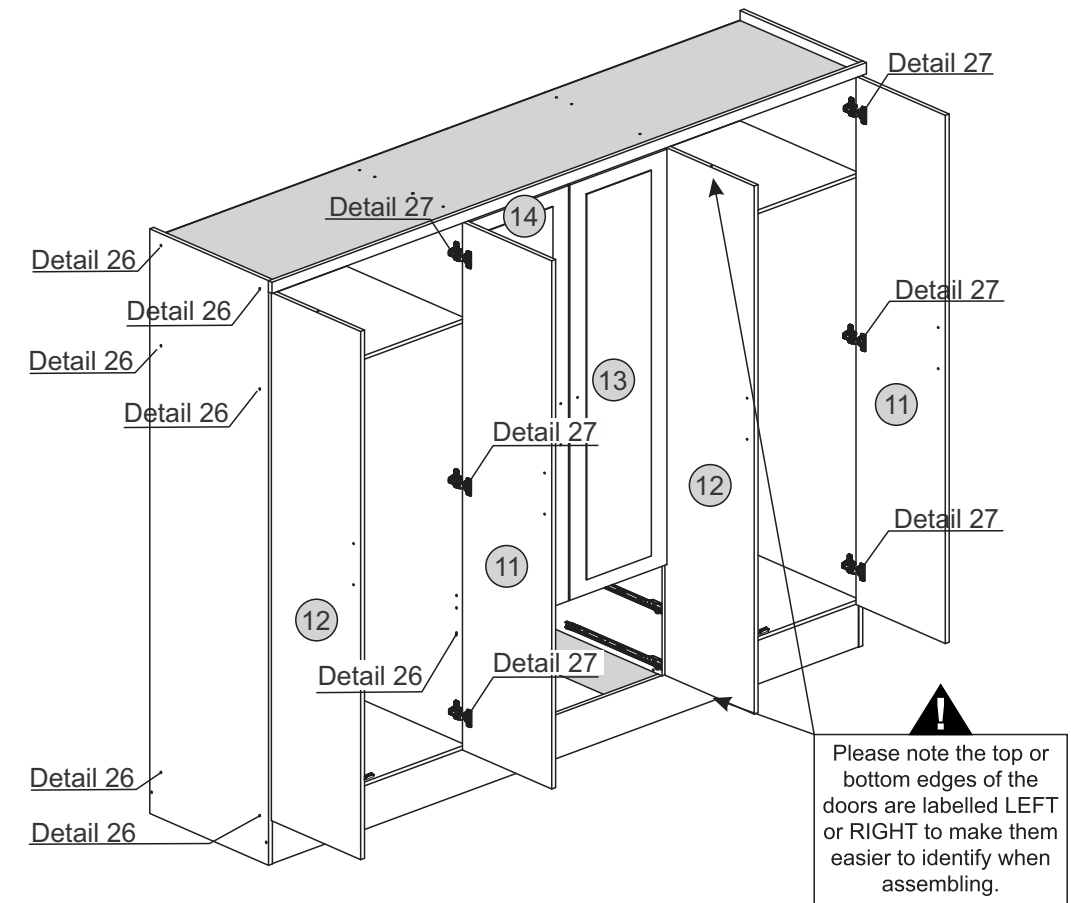
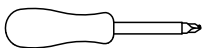

# STEP 37

## PARTS REQUIRED

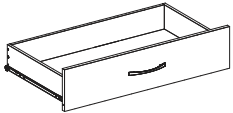
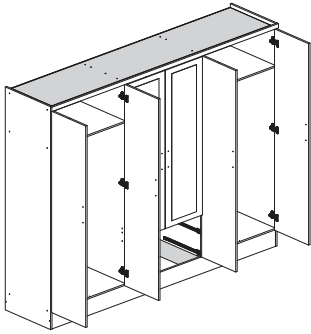

## HARDWARE REQUIRED

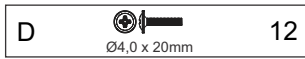

## TOOLS REQUIRED

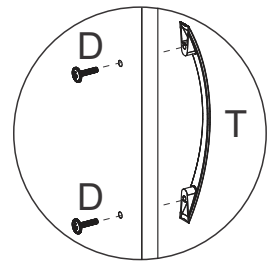
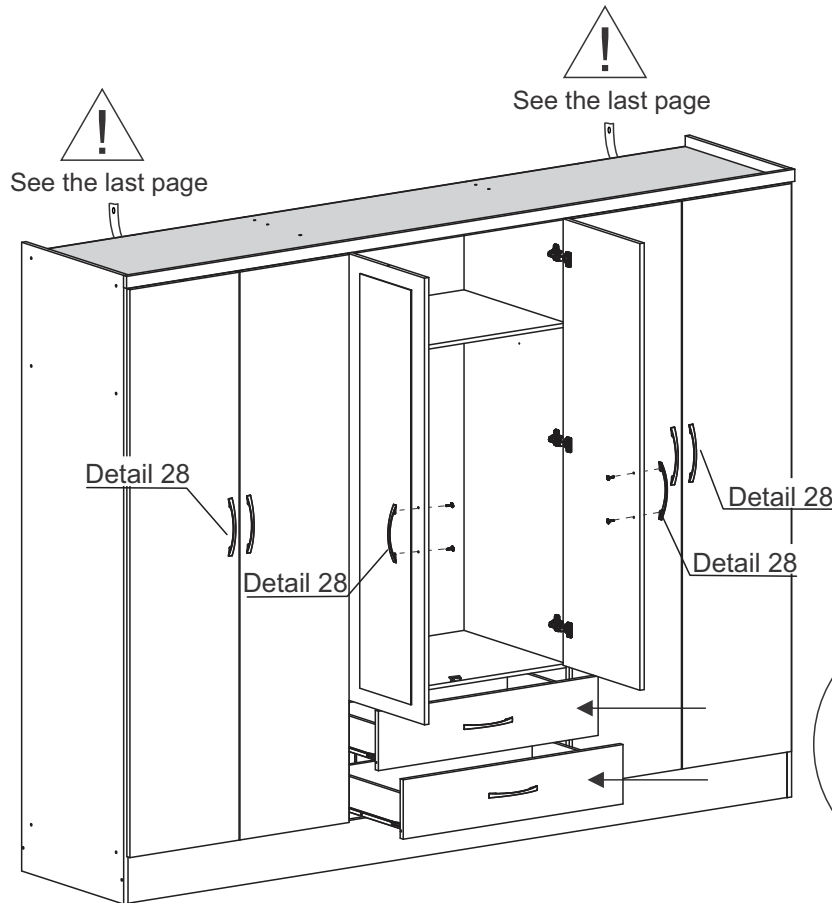
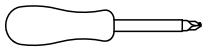

Detail 28

# STEP 38

## PARTS REQUIRED

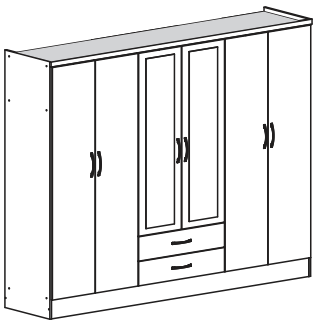

## HARDWARE REQUIRED

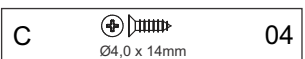

## TOOLS REQUIRED

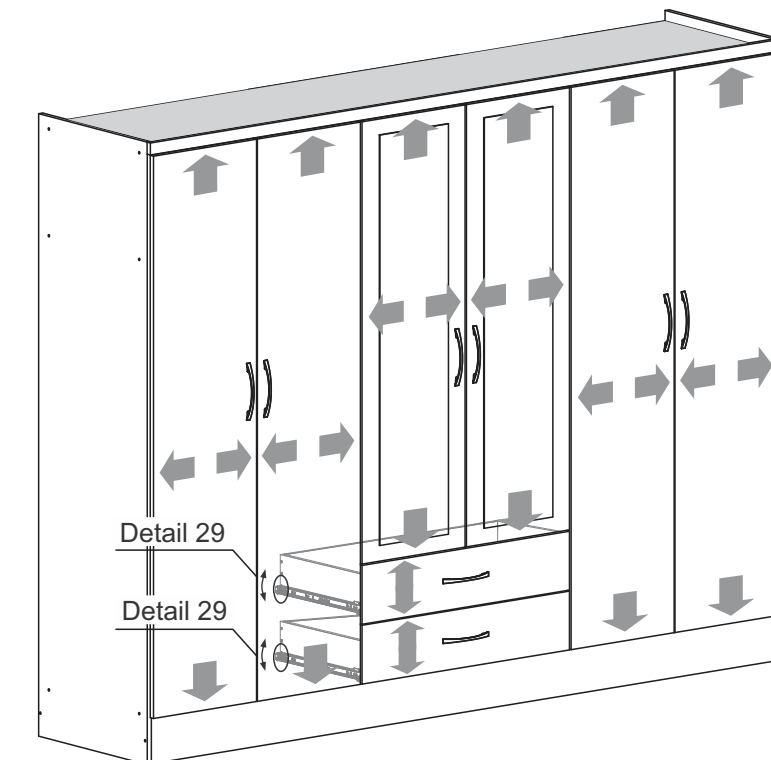
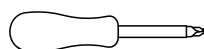

Drawer Adjustment

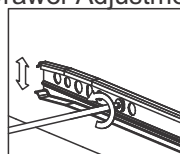

Drawer Lock

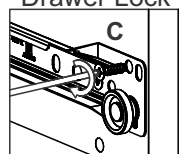

Detail 29

Height Adjustment

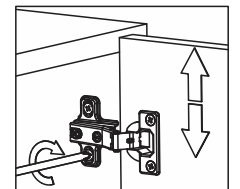

Internal Adjustment

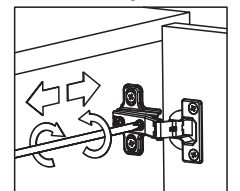

Depth Adjustment

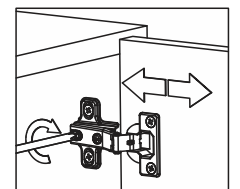
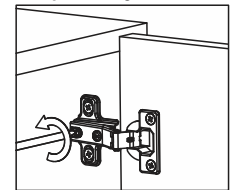



## WARNING

**Serious or fatal injuries can occur from furniture tipping over. To prevent the furniture from tipping over we recommend that it is permanently fixed to the wall.**

Wall fixings are not supplied with this product as different wall materials require different types of fixing devices.

Please make sure you use fixings suitable for the walls in your home.

