

BROOKLYN 6 DRAWER CHEST ASSEMBLY INSTRUCTIONS

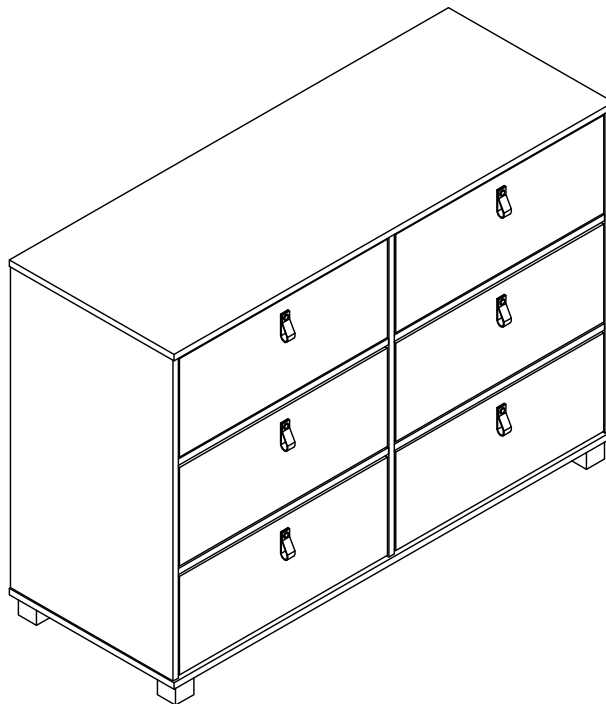
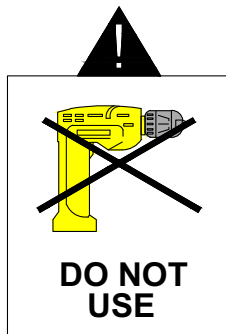

IMPORTANT FOR DOMESTIC USE ONLY PLEASE READ BEFORE YOU CONTINUE FURTHER

THE PRODUCT YOU HAVE PURCHASED WILL GIVE YOU MANY YEARS OF SERVICE IF YOU FOLLOW THE GUIDELINES FOR ITS SAFE ASSEMBLY AND PERIODIC MAINTENANCE AND CLEANING.

ASSEMBLE ON A SOFT CLEAN SURFACE.

DO NOT USE ANY TOOLS OTHER THAN THOSE SHOWN.

ANY SPANNERS OR ALLEN KEYS REQUIRED ARE INCLUDED WITH THE FITTINGS KIT.

DO NOT FOR ANY REASON USE A POWER TOOL TO ASSEMBLE THIS PRODUCT. ITS USE WILL INVALIDATE ANY CLAIM YOU MAY HAVE AND COULD MAKE THIS PRODUCT UNSAFE.

DEPENDING ON THE AMOUNT OF USE THIS PRODUCT RECEIVES IT MAY BE NECESSARY TO TIGHTEN UP THE FIXINGS FROM TIME TO TIME. THIS IS COMPLETELY NORMAL FOR ANY FLAT PACK FURNITURE. DO NOT OVERTIGHTEN FIXING.

FOR CLEANING, YOU MAY USE A DAMP CLOTH (NOT WET) DO NOT USE POLISH, DETERGENT OR CHEMICAL CLEANERS.



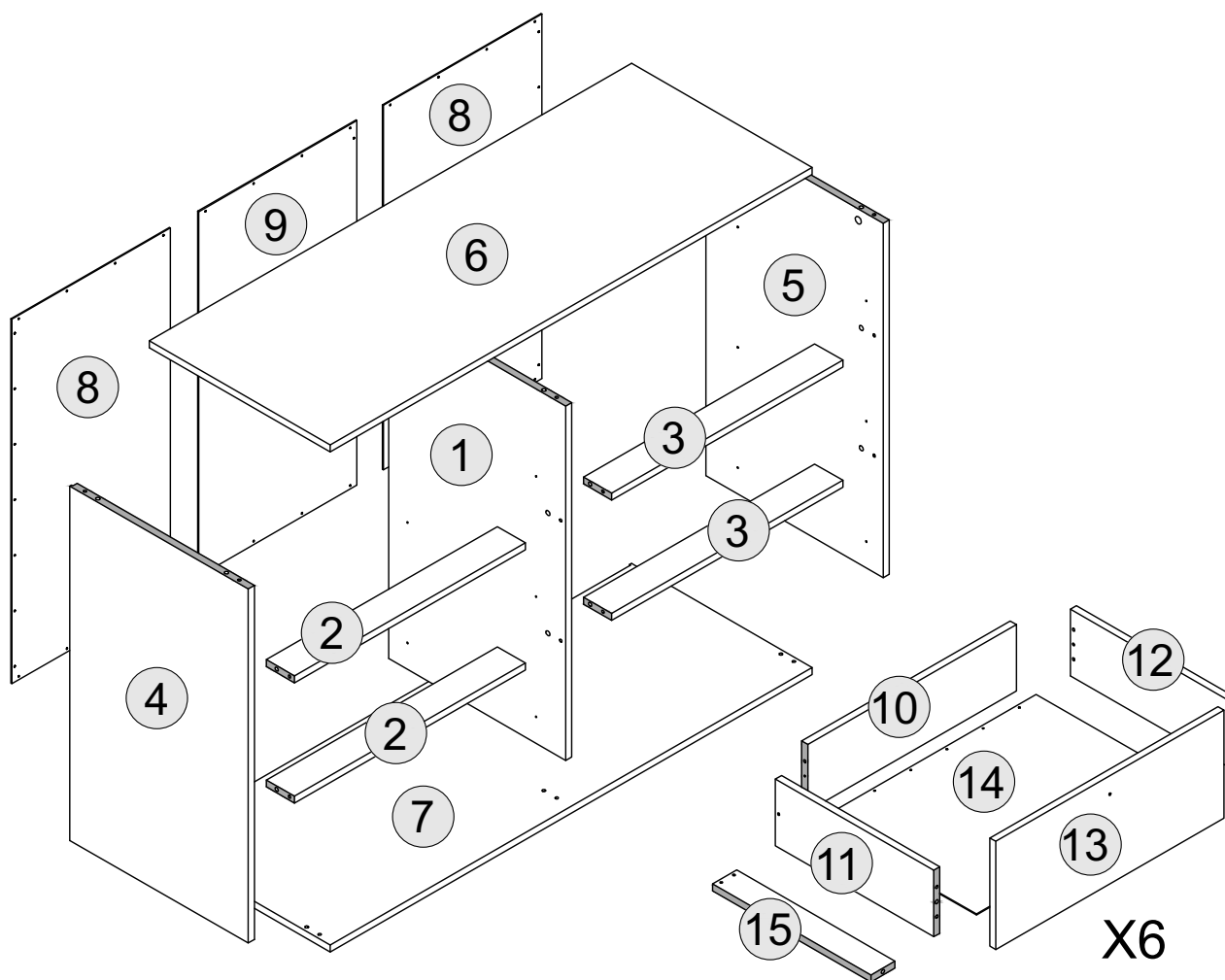









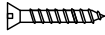



THE SURFACE OF THIS ITEM IS NOT HEAT RESISTANT. ALWAYS USE A PLACE MAT UNDER HOT OR COLD ITEMS TO PREVENT MARKING.

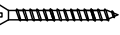

PART LIST

<u>Part Number</u>	<u>Part Code</u>	<u>Part Description</u>	<u>Quantity</u>	<u>Carton</u>
1	S100-102-165-EU1-01	Centre Panel	1	2/2
2	S100-102-165-EU1-02	Crossbar - Left	2	2/2
3	S100-102-165-EU1-03	Crossbar - Right	2	2/2
4	S100-102-165-EU1-04	Side Panel - Left	1	1/2
5	S100-102-165-EU1-05	Side Panel - Right	1	1/2
6	S100-102-165-EU1-06	Top Panel	1	1/2
7	S100-102-165-EU1-07	Bottom Panel	1	1/2
8	S100-102-165-EU1-08	Back Panel 1	2	2/2
9	S100-102-165-EU1-09	Back Panel 2	1	2/2
10	S100-102-165-EU1-10	Drawer Back	6	2/2
11	S100-102-165-EU1-11	Drawer Side - Left	6	1/2
12	S100-102-165-EU1-12	Drawer Side - Right	6	1/2
13	S100-102-165-EU1-13	Drawer Front	6	2/2
14	S100-102-165-EU1-14	Drawer Base	6	2/2
15	S100-102-165-EU1-15	Drawer Bottom Support Rail	6	1/2

HARDWARE LIST

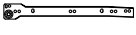
A		DOWEL 6 X 30MM	68 PCS	O		DRAWER RUNNER B - L/R	12 PCS
B		ALLEN KEY	1 PC	P		SCREW M4 X 38MM	12 PCS
C		SCREW M6 X 50MM	6 PCS	Q		ANTI - TIP STRAP	2 PCS
D		SCREW M3.5 X 16MM	36 PCS	R		SCREW M4 X 16MM	2 PCS
E		TACK	38 PCS				
F		SCREW M4 X 50MM	20 PCS				
G		HANDLE	6 PCS				
H		PLASTIC H STRIP	2 PCS				
I		SCREW M4 X 30MM	12 PCS				
J		HANDLE SCREW 19MM	6 PCS				
K		SCREW M3.5 X 12MM	84 PCS				
L		CAM BOLT + CAM NUT	32 SET				
M		WOOD FOOT	5 PCS				
N		DRAWER RUNNER A - L/R	12 PCS				

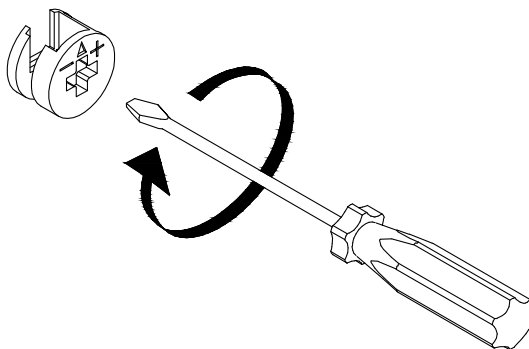

(SCREWDRIVER NOT PROVIDED)

USE A FLAT HEAD SCREWDRIVER TO TIGHTEN THE CAM NUTS. A QUARTER TURN CLOCKWISE IS ALL THAT IS NEEDED.

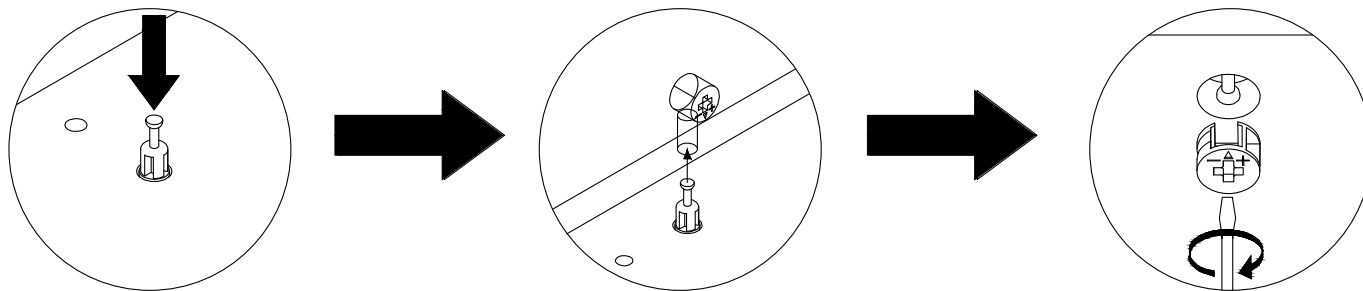

STEP 1 - PUSH CAM BOLT INTO INSERT.

STEP 2 - ALIGN THE CAM BOLT WITH THE HOLE AND PUSH TOGETHER UNTIL FLUSH. (MAKE SURE THE ARROW OF THE CAM LOCK IS POINTING TOWARD THE EDGE OF THE PANEL.)





STEP 3 - THE HEAD OF THE BOLT GOES INTO THE WIDE MOUTH OF THE CAM LOCK. YOU THEN TURN THE LOCK SO THE NARROW PART CLOSES OVER THE BOLT.

STEP 1

PARTS REQUIRED

1 - CENTRE PANEL x1

HARDWARE REQUIRED

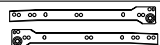
- A  04
- K  24
- L  02
- L  04
- N  06

TOOLS REQUIRED

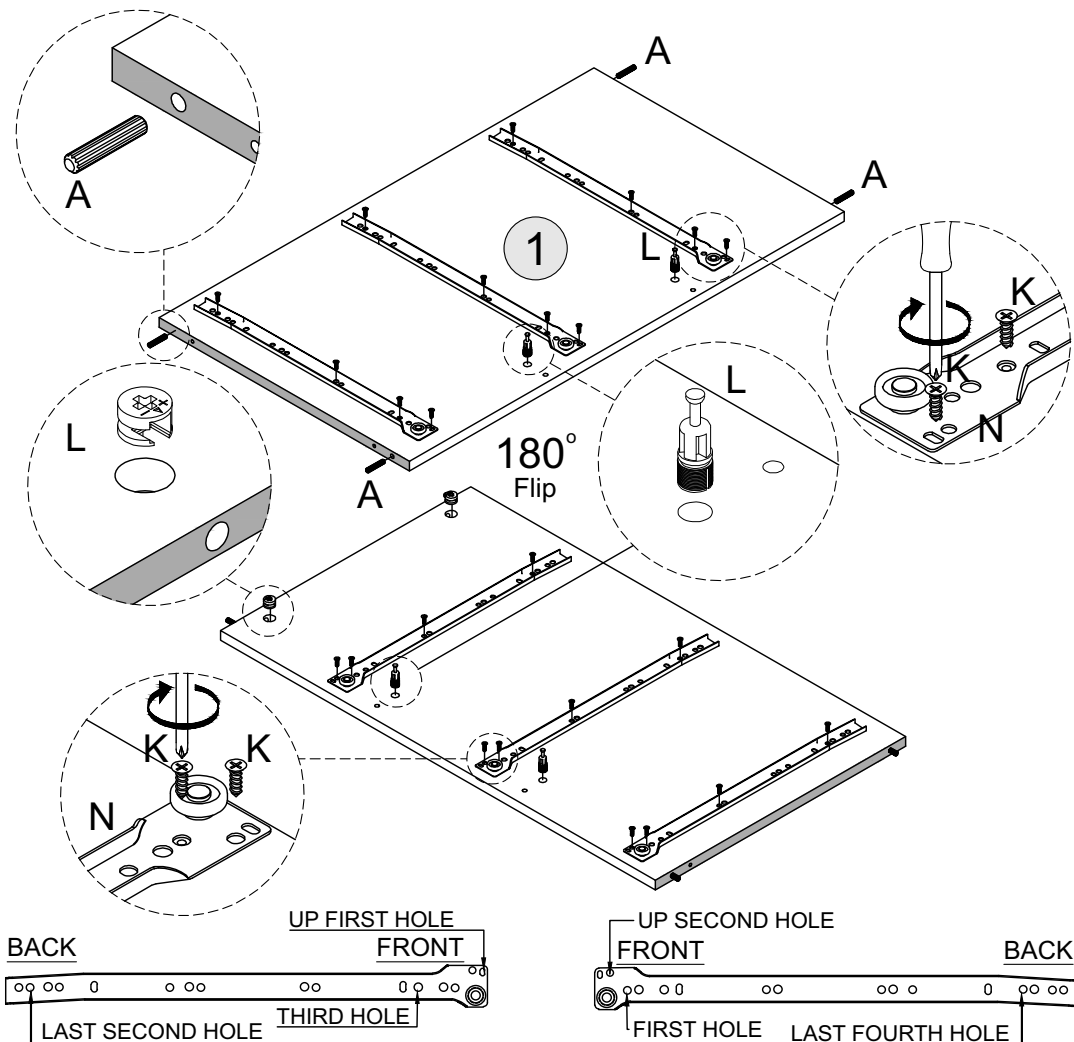
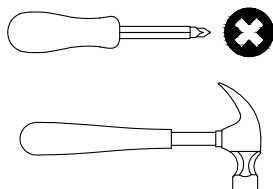





STEP 2

PARTS REQUIRED

4 - SIDE PANEL - LEFT x1

HARDWARE REQUIRED

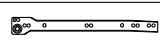
- A  04
- K  12
- L  02
- L  02
- N  03

TOOLS REQUIRED

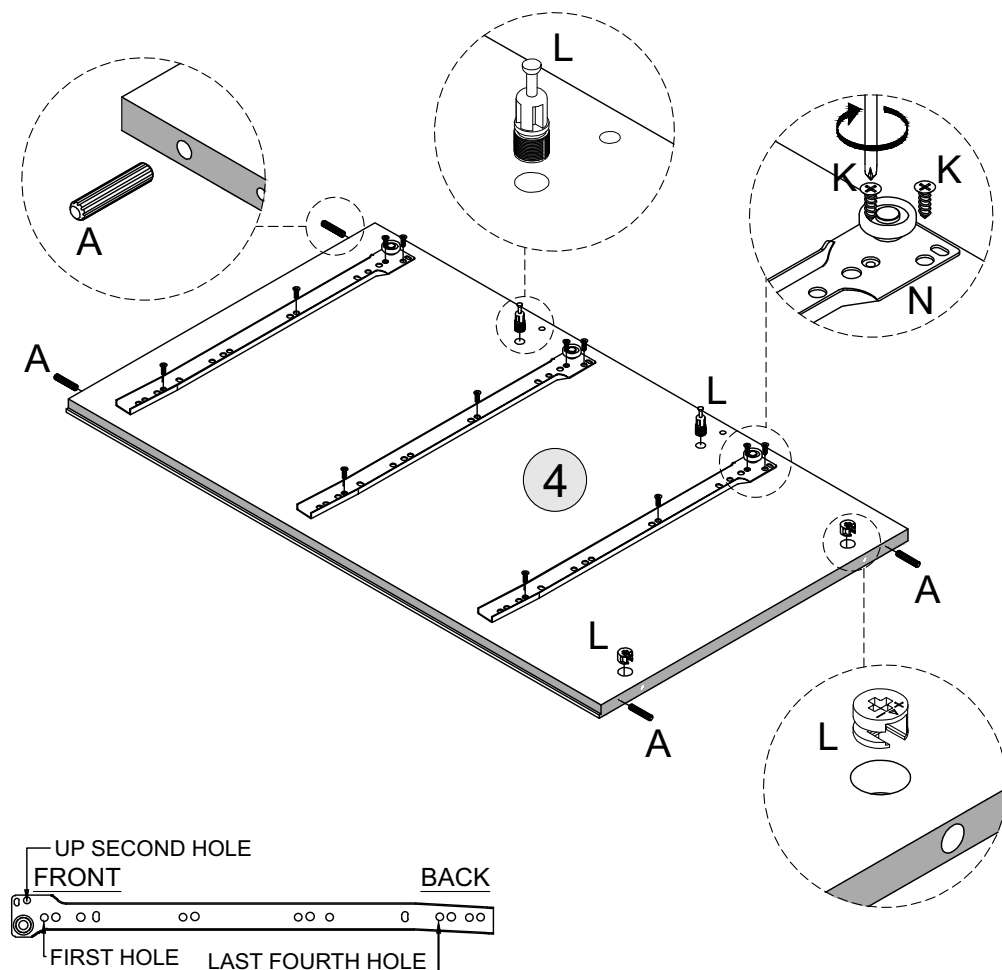
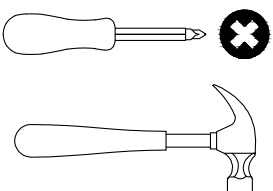

STEP 3

PARTS REQUIRED

5 - SIDE PANEL - RIGHT x1

HARDWARE REQUIRED

A  04

K  12

L  02

L  02

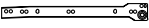
N  03

TOOLS REQUIRED

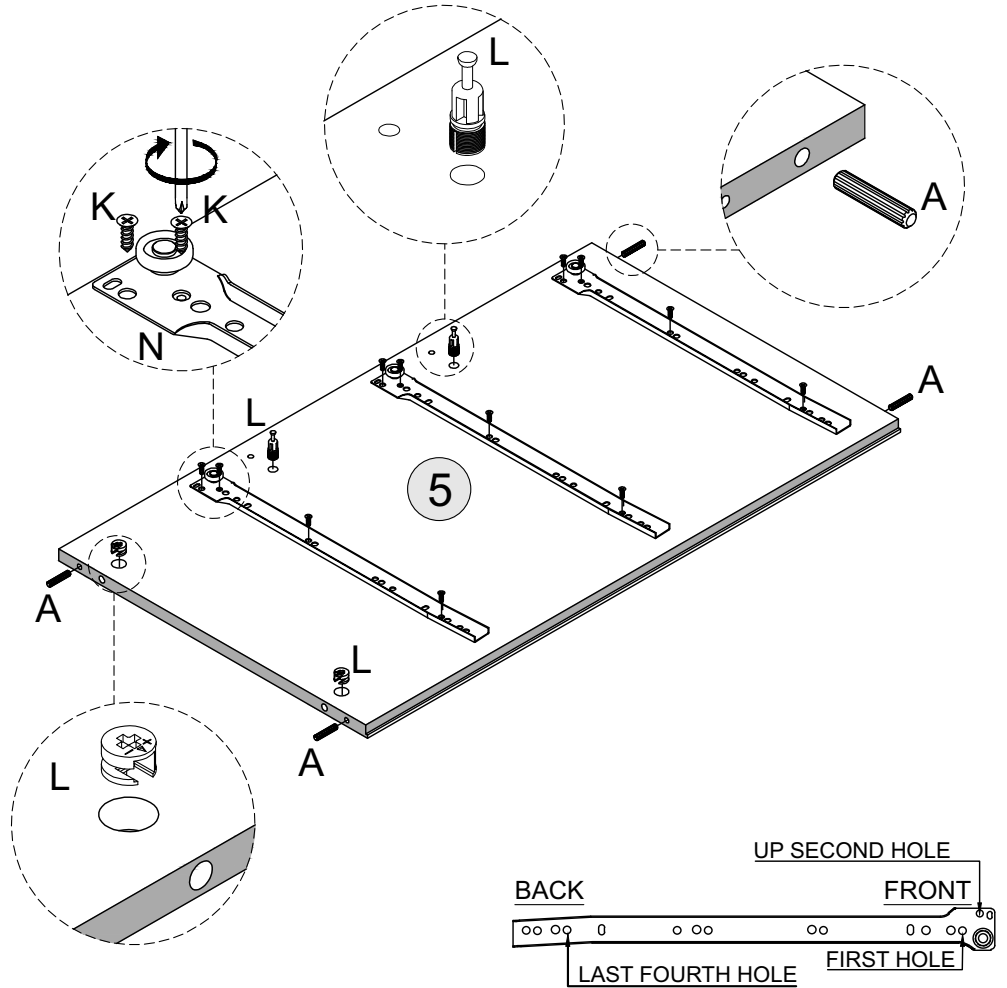
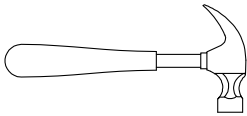
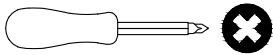

STEP 4

PARTS REQUIRED

2 - CROSSBAR - LEFT x2

3 - CROSSBAR - RIGHT x2

6 - TOP PANEL x1

HARDWARE REQUIRED

A  08

L  08

L  06

TOOLS REQUIRED

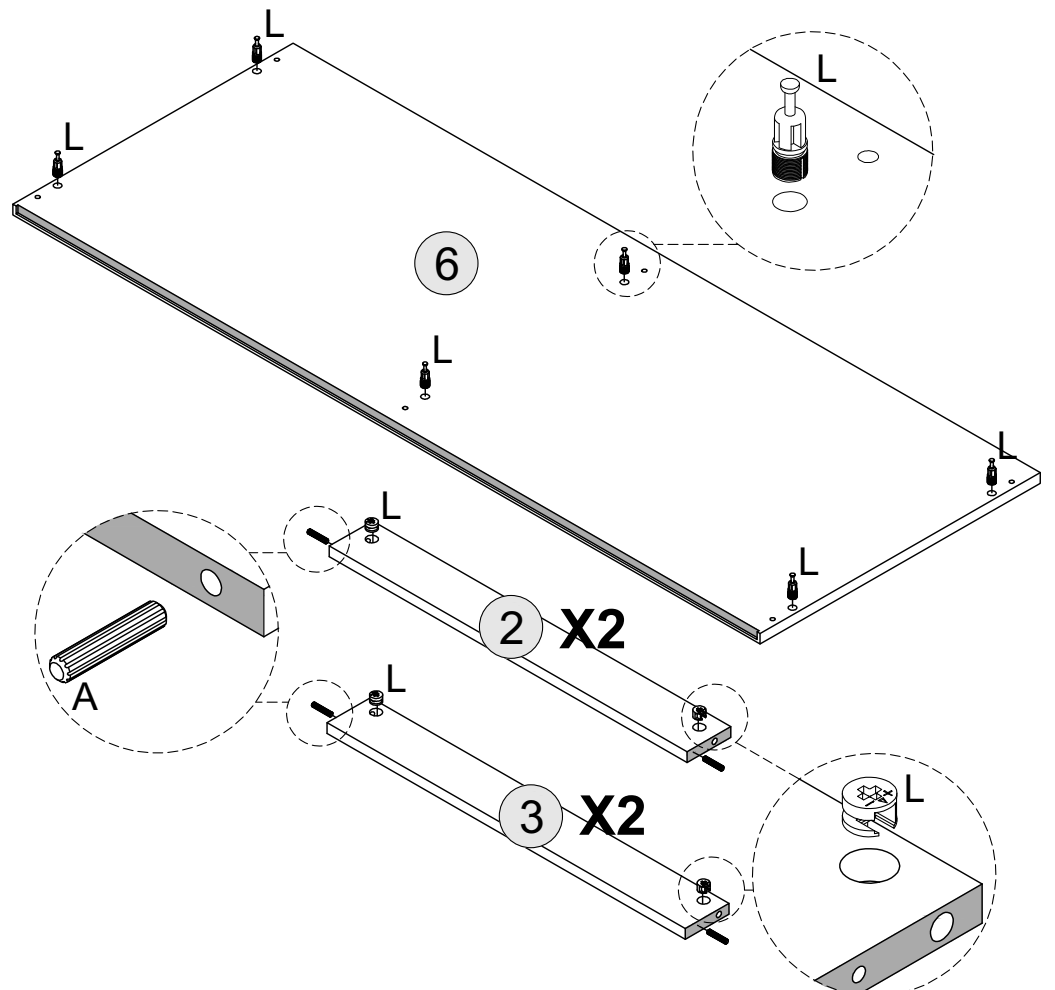
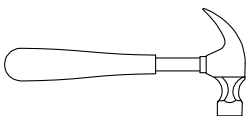

STEP 5

PARTS REQUIRED

1 - CENTRE PANEL	x1
2 - CROSSBAR - LEFT	x2
3 - CROSSBAR - RIGHT	x2

HARDWARE REQUIRED

TOOLS REQUIRED

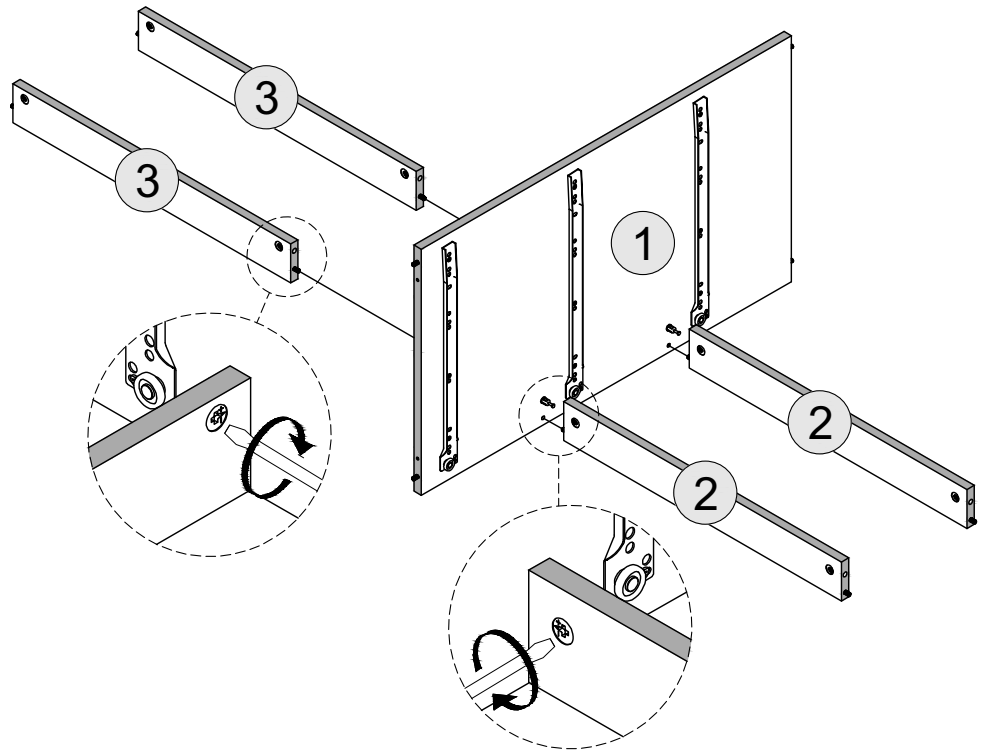

STEP 6

PARTS REQUIRED

4 - SIDE PANEL - LEFT	x1
5 - SIDE PANEL - RIGHT	x1

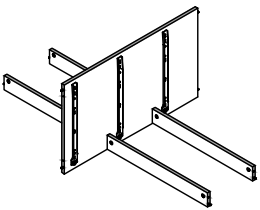

HARDWARE REQUIRED

TOOLS REQUIRED

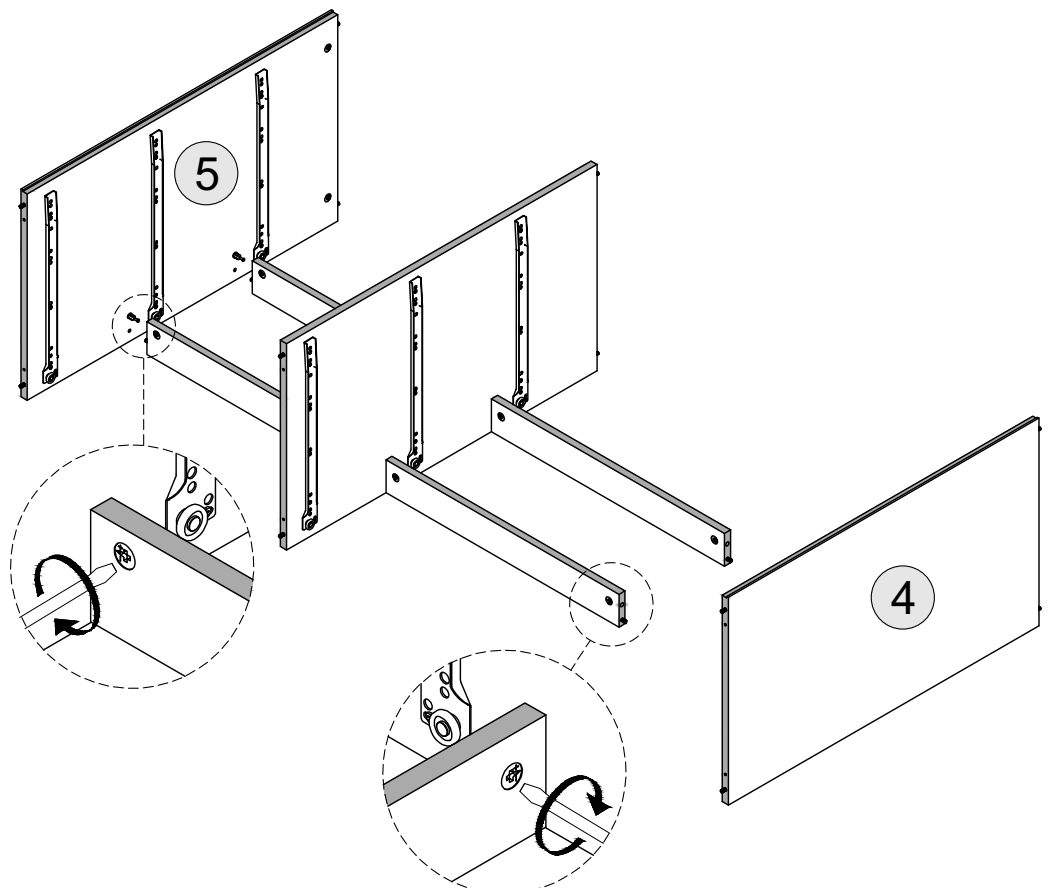
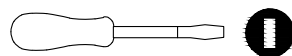

STEP 7

PARTS REQUIRED

6 - TOP PANEL x1

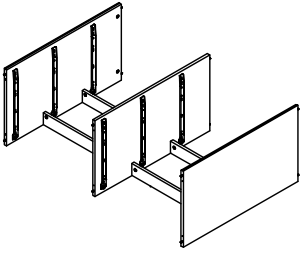

HARDWARE REQUIRED

TOOLS REQUIRED

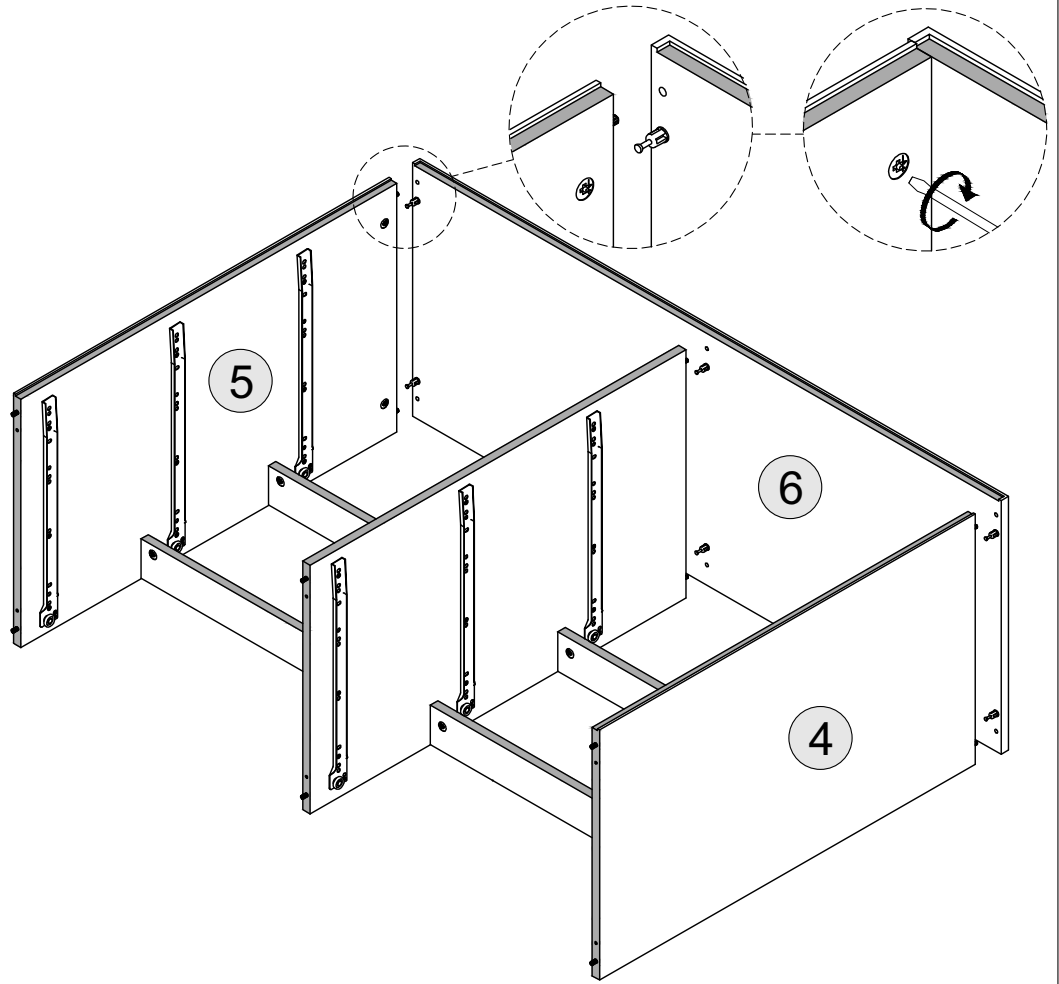

STEP 8

PARTS REQUIRED

7 - BOTTOM PANEL x1

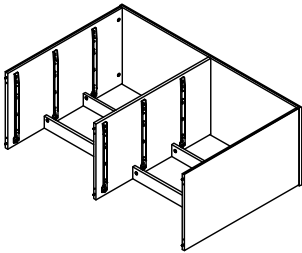

HARDWARE REQUIRED

C  06

TOOLS REQUIRED

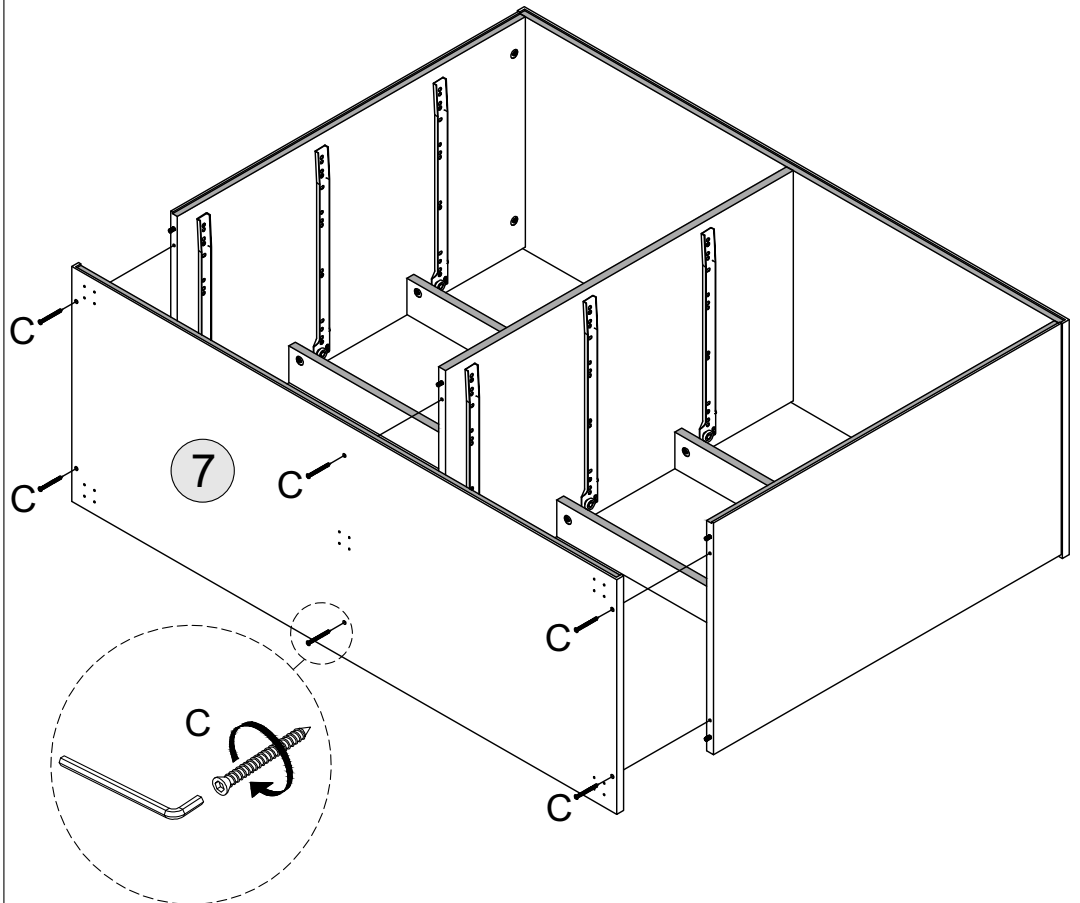

STEP 9

PARTS REQUIRED

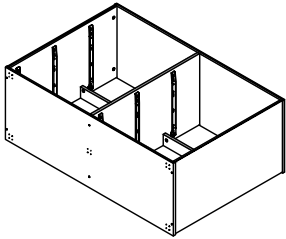

HARDWARE REQUIRED



TOOLS REQUIRED

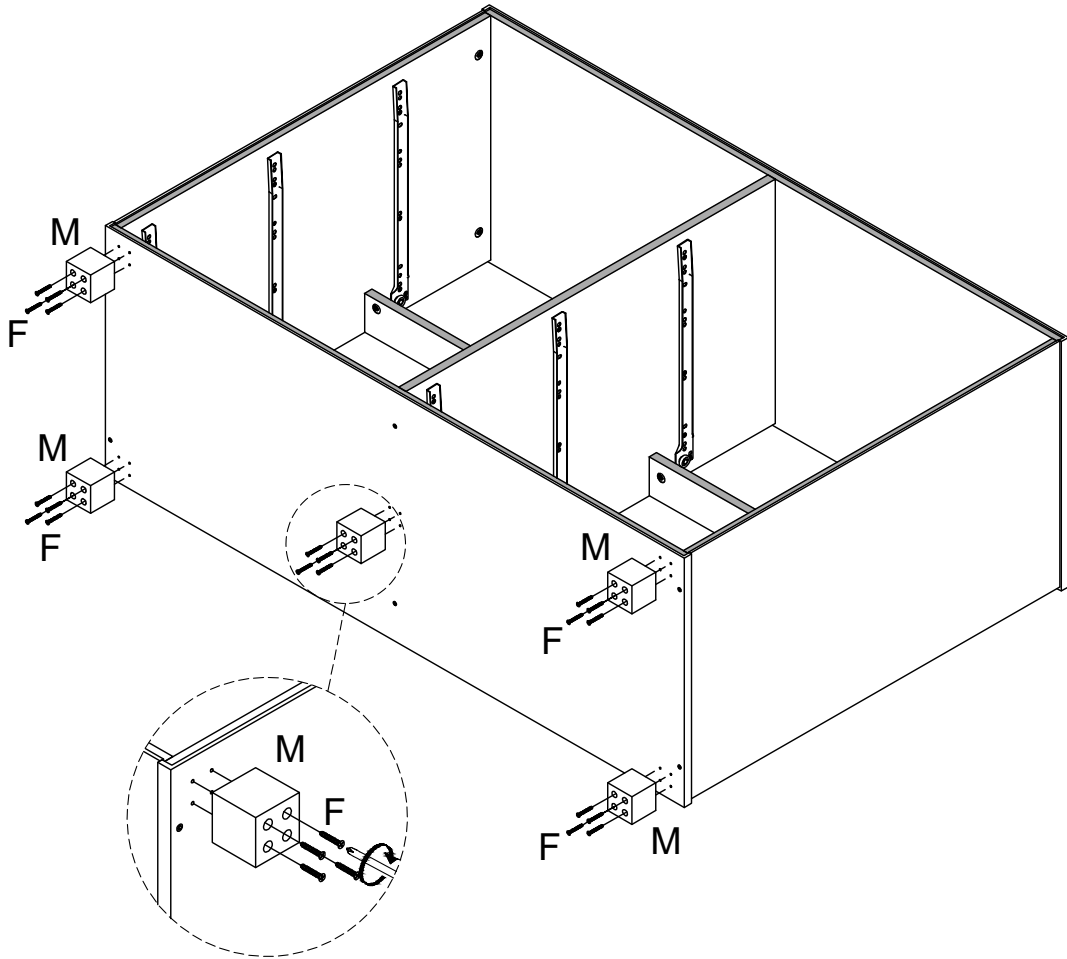
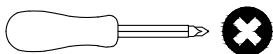

STEP 10

PARTS REQUIRED

8 - BACK PANEL 1 x2

9 - BACK PANEL 2 x1

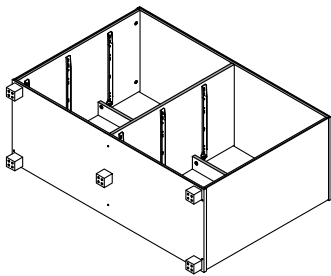

HARDWARE REQUIRED

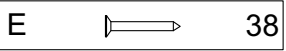

TOOLS REQUIRED

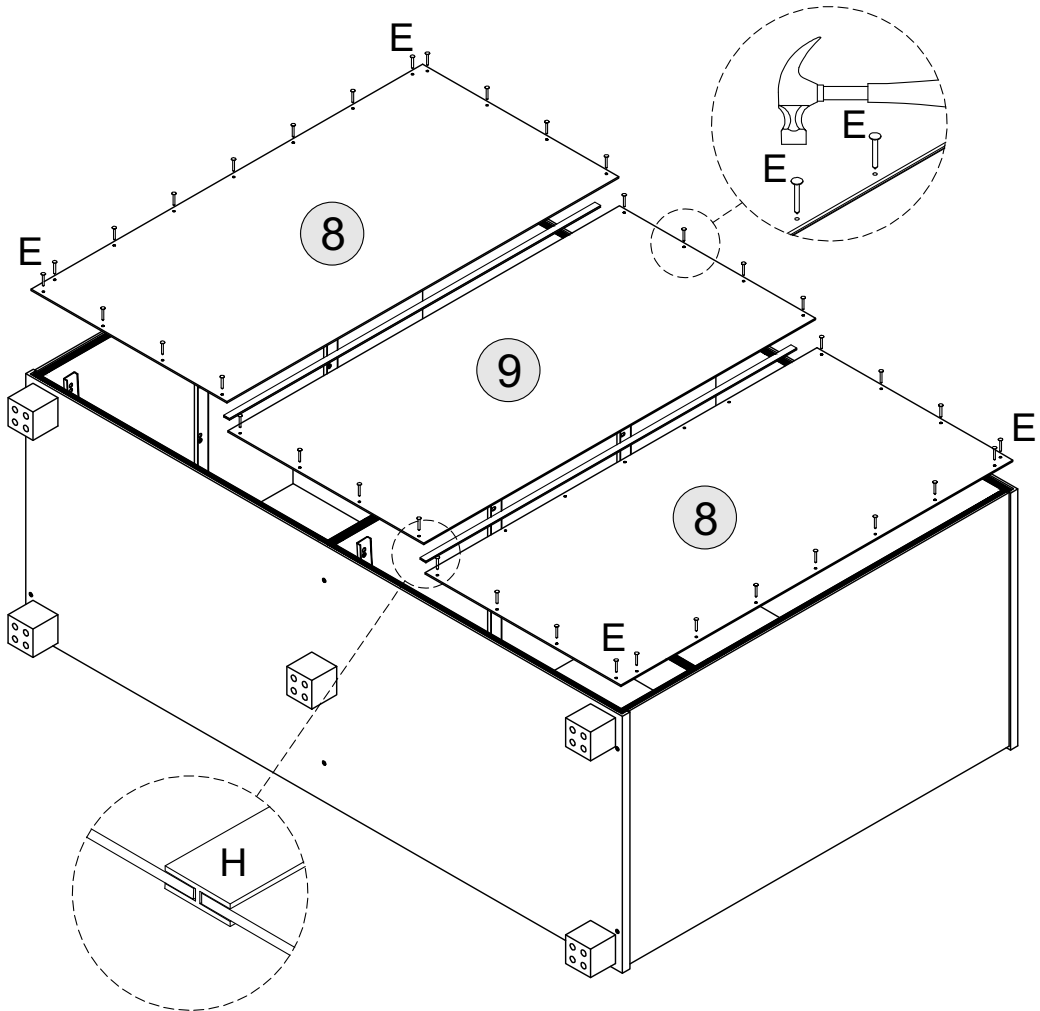
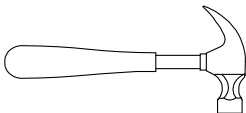



STEP 11

PARTS REQUIRED

10 - DRAWER BACK	x6
11 - DRAWER SIDE-LEFT	x6
12 - DRAWER SIDE-RIGHT	x6
13 - DRAWER FRONT	x6

HARDWARE REQUIRED

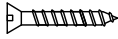
A		48
L		18
L		12
P		12

TOOLS REQUIRED

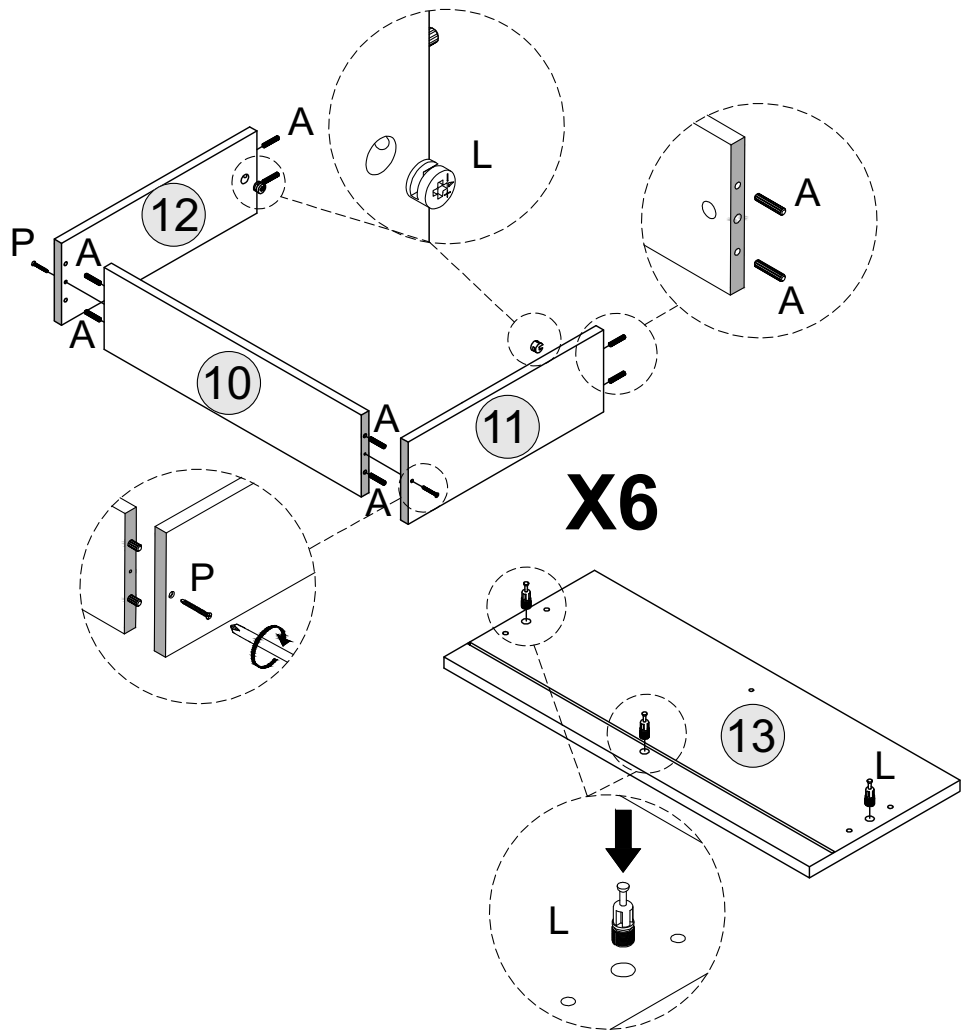
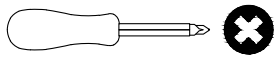



STEP 12

PARTS REQUIRED

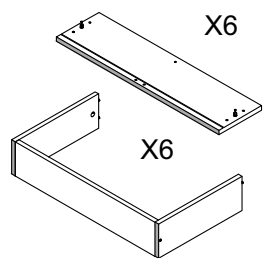
14 - DRAWER BASE	x6
------------------	----



HARDWARE REQUIRED

G		06
J		06
K		36

TOOLS REQUIRED

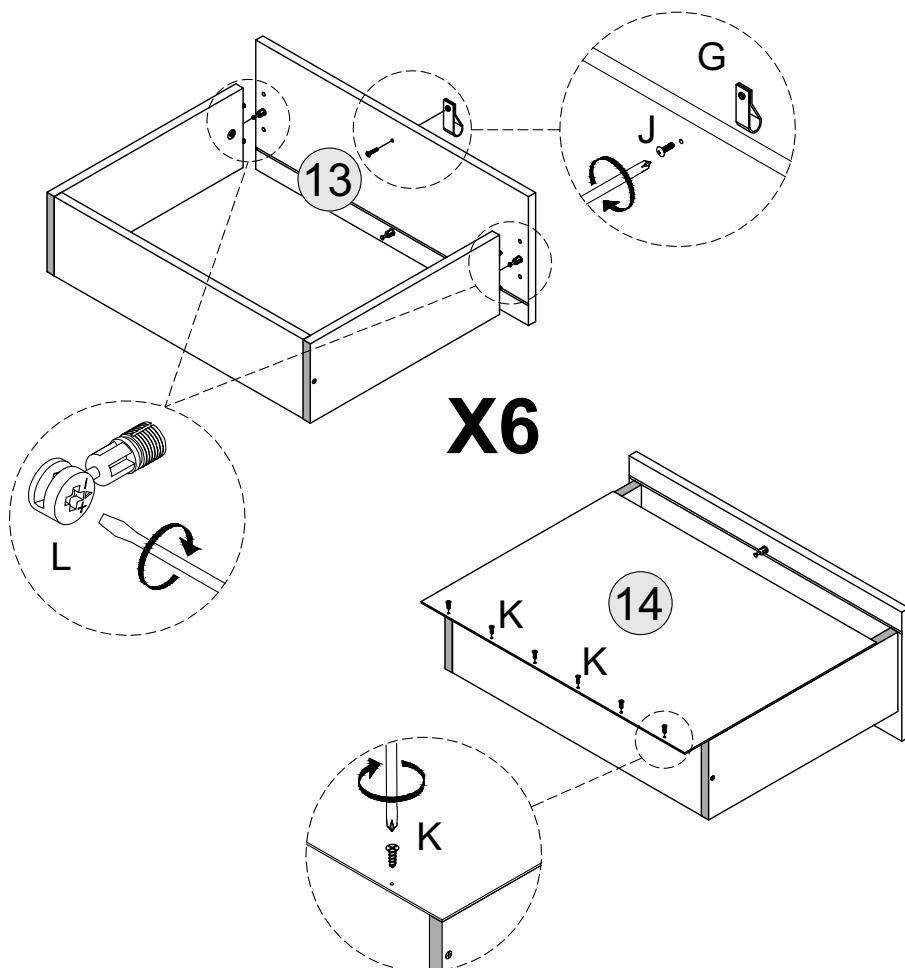
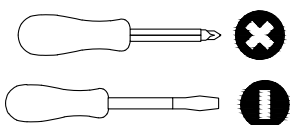

STEP 13

PARTS REQUIRED

15 -DRAWER BOTTOM SUPPORT RAIL x6

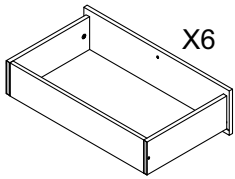

HARDWARE REQUIRED

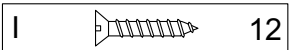
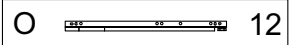
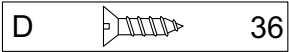

TOOLS REQUIRED

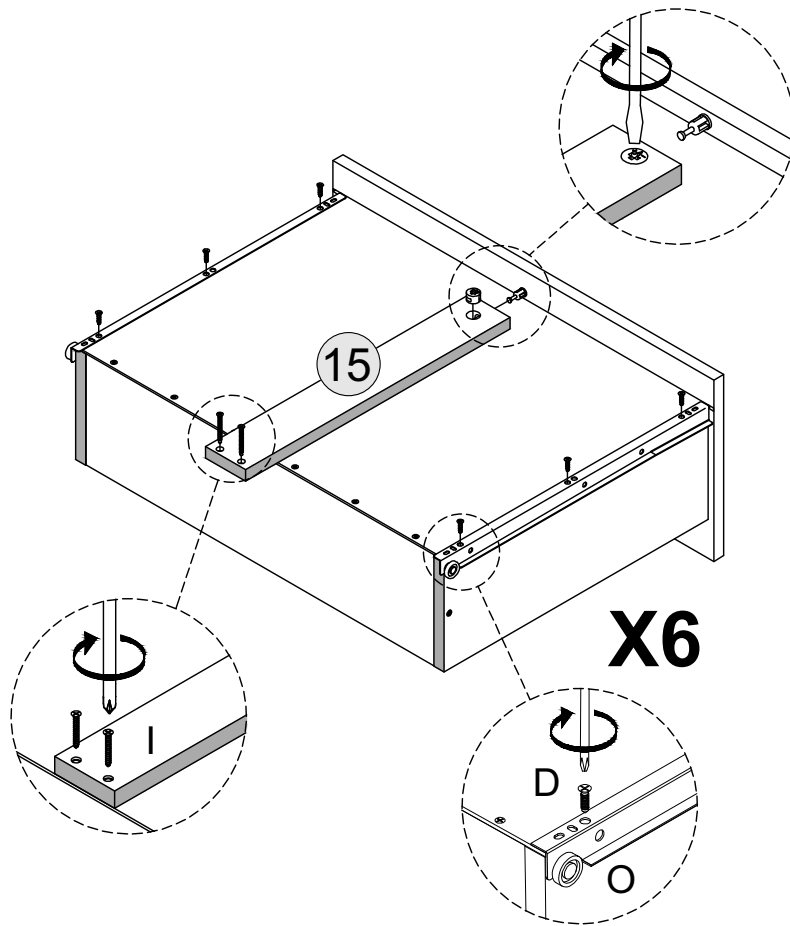
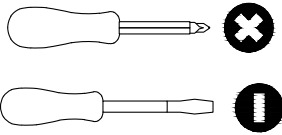

STEP 14

PARTS REQUIRED

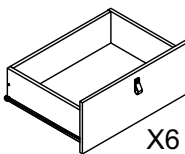
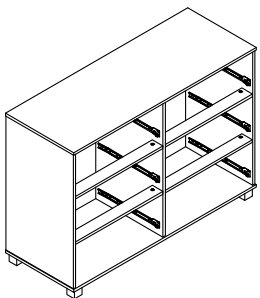

HARDWARE REQUIRED

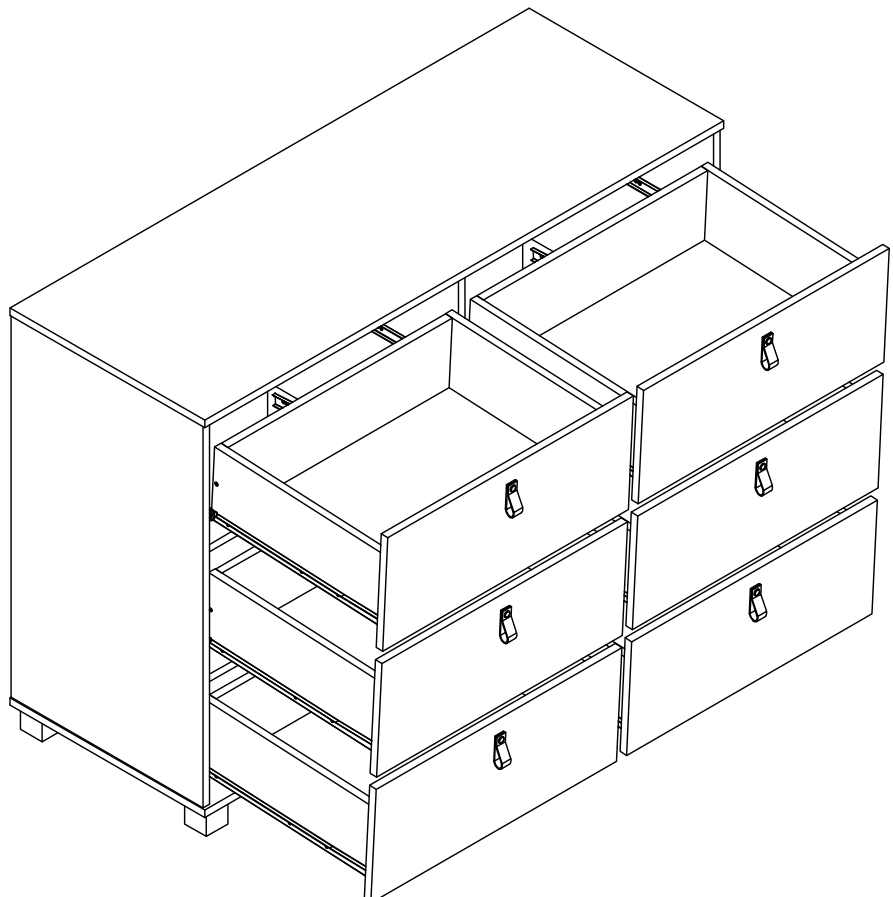

STEP 15

PART REQUIRED

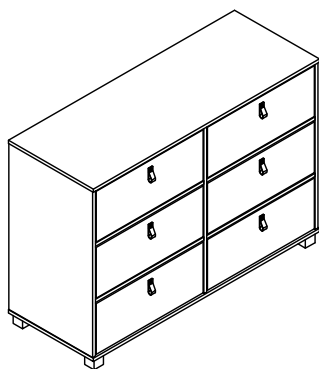

HARDWARE REQUIRED

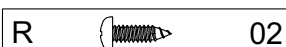

TOOLS REQUIRED

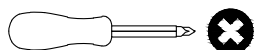

WARNING

Serious or fatal injuries can occur from furniture tipping over. To prevent the furniture from tipping over we recommend that it is permanently fixed to the wall.

Wall fixings are not supplied with this product as different wall materials require different types of fixing devices. Please make sure you use fixings suitable for the walls in your home.

