

INDUSTRIAL BOSTON 3+3 DRAWER CHEST

ASSEMBLY INSTRUCTIONS

Thank you for purchasing the *INDUSTRIAL BOSTON 3+3 DRAWER CHEST*.
Please read the instructions carefully to ensure safe operation of the product.

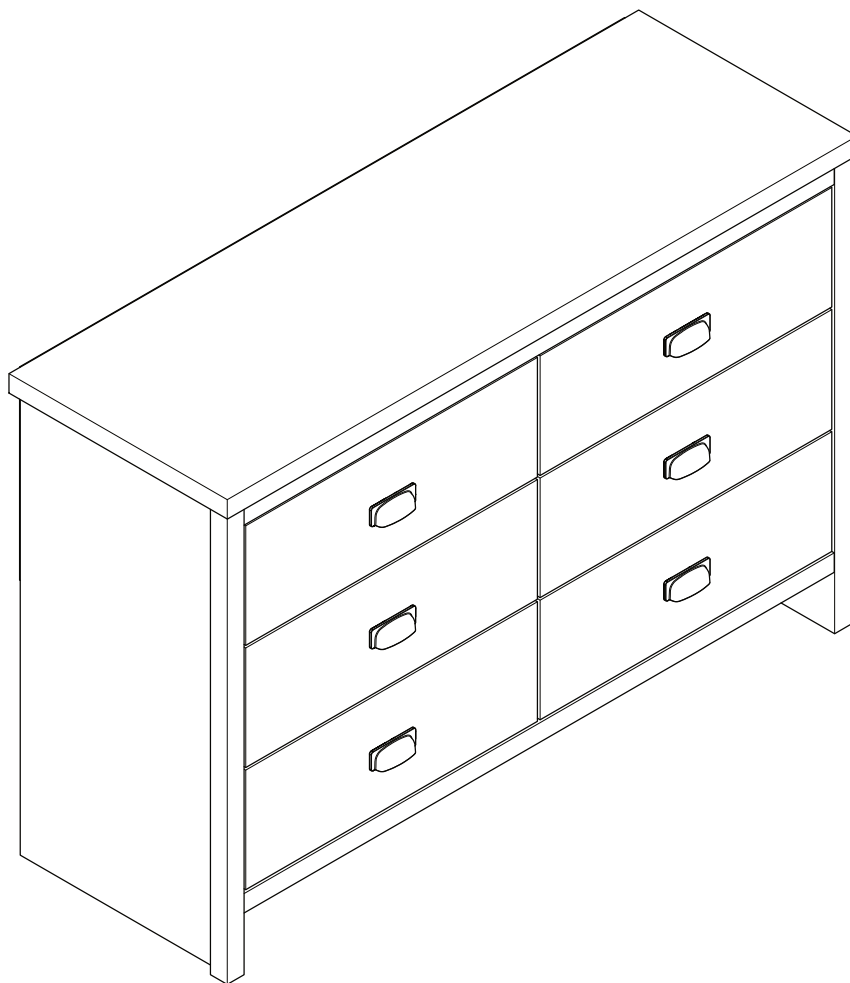

Size : 1125 x 393 x 760mm

PLEASE READ this sheet prior to assembly to familiarise yourself with the various stages of construction.

Carefully open the pack supplied and check the contents against the parts and fittings check list. Do not destroy any of the packaging until you are certain that you have all the necessary parts for the assembly.

CAUTION: There are small components used in the construction of this unit. These loose items should be kept away from young children whilst assembling your unit to avoid the danger of choking hazards.

Tools Required

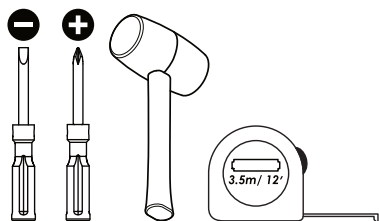

Person Required



Approximate Assembly Time

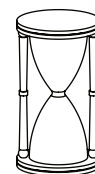

1.5 Hour

IMPORTANT - READ CAREFULLY - RETAIN THESE INSTRUCTIONS FOR FUTURE REFERENCE.

INFORMATION

- Due to the size of this product we recommend that it is assembled in the room intended for use.
- When you are ready to start, make sure that you have the right tools, plenty of space and a clean, dry area for assembly.
- Unwrap all packaging materials and place the components on top of the carton box or on a clean floor to prevent it from scratching.
- Check the pack and make sure you have all the parts listed.
- Ensure that this product is fully assembled as illustrated before use.
- Check all screws or bolts are tightened and inspect regularly.
- This product should only be used on firm, level ground.
- Keep small parts out of reach of children.
- Make sure the legs remain in contact with the ground.
- Tools not included.

WARNINGS

- DO NOT use power tools to construct this product.
- DO NOT tighten screws until fully assembled.
- DO NOT over tighten screws or bolts.
- DO NOT use this product if parts are missing, damaged or worn.
- DO NOT sit or stand on the product.
- It is essential that this unit is fixed to the wall with the brackets provided for safety reasons. NB wall fixings are not included. Please source suitable fixings for your wall type. If in doubt please consult a qualified tradesperson.
- WARNING: Always ensure the area to be drilled is free from hidden electrical wires, water or gas pipes.



CARE INFORMATION

- Never use scourers, abrasives or chemical cleaners.
- To clean wipe with a sponge and warm soapy water. Do not use solvent based cleaners or detergents as they can bleach or damage the product.

SPECIAL TIPS FOR FITTING DRAWER

DRAWER RUNNER - A

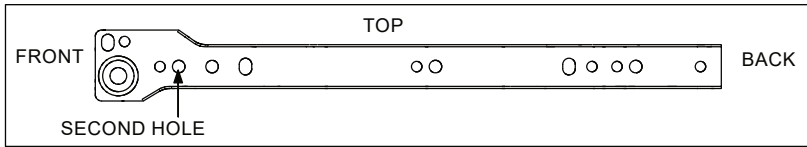

- Fix the first screw on the second hole on drawer runner as shown.
- Fix the second screw following the holes on panel.

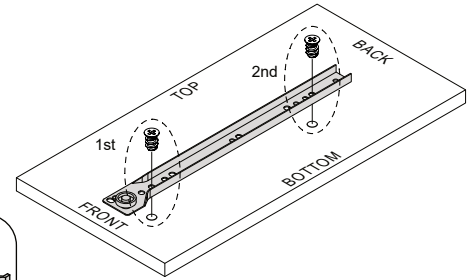
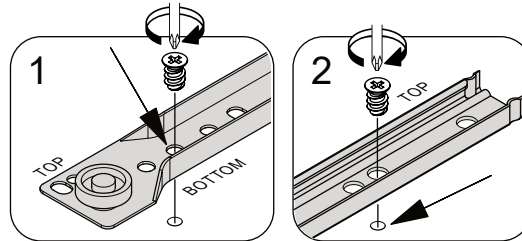

- Ensure the position of the drawer runner is correct as showed above.

DRAWER RUNNER - B

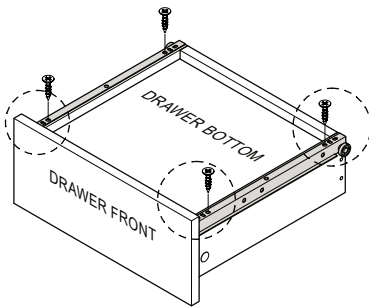
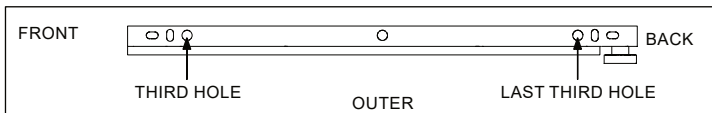

- Ensure the position of the drawer runner is correct as showed above.

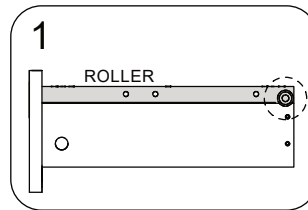

- Push the runner to drawer front.

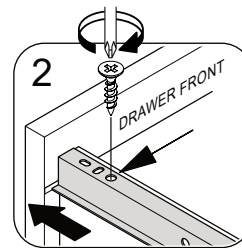

- Fix the first screw on the third hole from front.

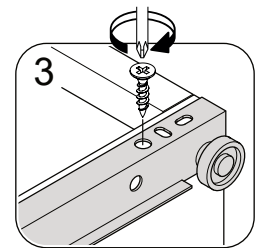

- Fix the second screw on the last third hole.

INSTALL DRAWER TO CABINET

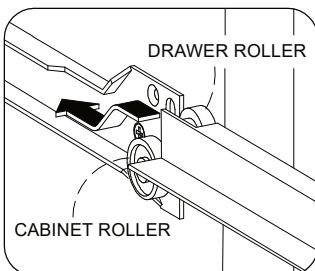

- Locate both roller on drawer box and roller on cabinet.

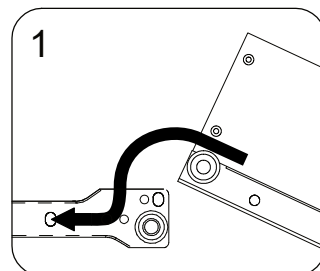

- Align the roller on drawer box on top of the roller on cabinet.

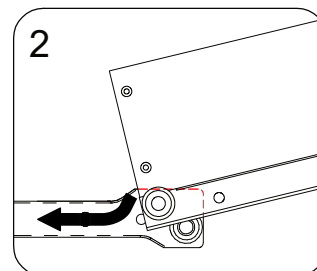

- Push inside the drawer box.

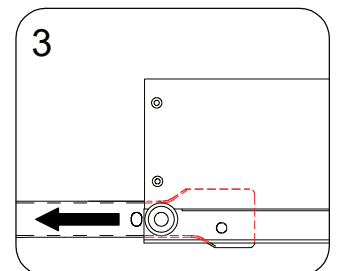

- Ensure the roller is in the track of drawer slide before push to the end.

Please check the pack contents before assembling the product. If any components are missing, please contact your retailer. The fittings pack contains small items that should be kept away from small children.

Parts

CODE	PART NAME	QTY	DIMENSION
A	Side Panel - L	1	30 x 385 x 725mm
B	Side Panel - R	1	30 x 385 x 725mm
C	Top Panel	1	30 x 390 x 1125mm
D	Bottom Bar	1	30 x 75 x 1055mm
E	Centre Panel	1	15 x 369 x 725mm
F	Back Bottom Bar	2	15 x 110 x 520mm
G	Back Bar	2	15 x 75 x 520mm
H	Top Bar	1	30 x 50 x 1055mm

CODE	PART NAME	QTY	DIMENSION
I	Drawer Front - L	3	15 x 185 x 521mm
J	Drawer Front - R	3	15 x 185 x 521mm
K	Drawer Side - L	6	5 x 140 x 296mm
L	Drawer Side - R	6	5 x 140 x 296mm
M	Drawer Back	6	15 x 140 x 465mm
	Drawer Bottom	6	3 x 290 x 475mm
	Back Panel	1	3 x 330 x 1081mm
	Bottom Back Panel	1	3 x 330 x 1081mm

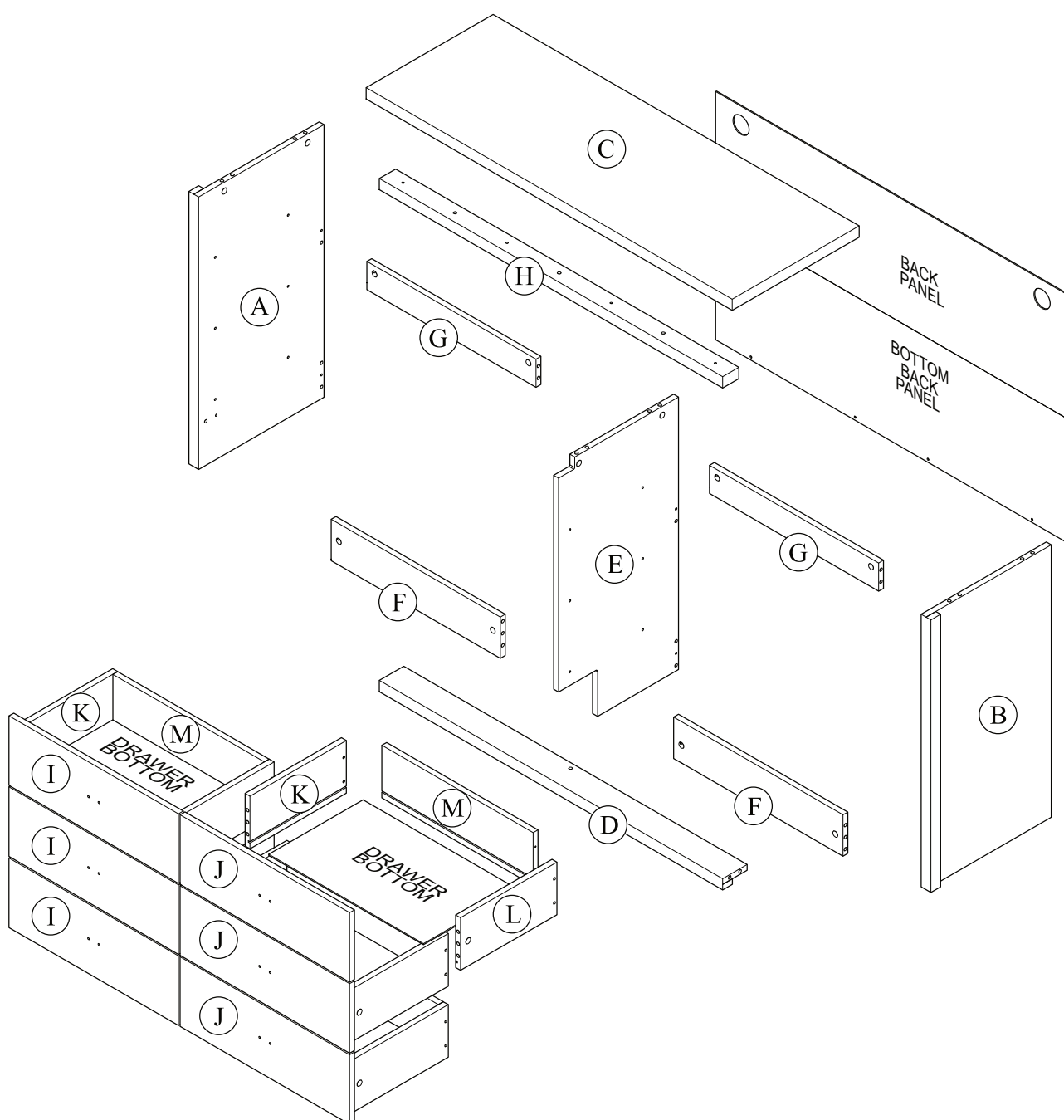

Fixings (to scale)

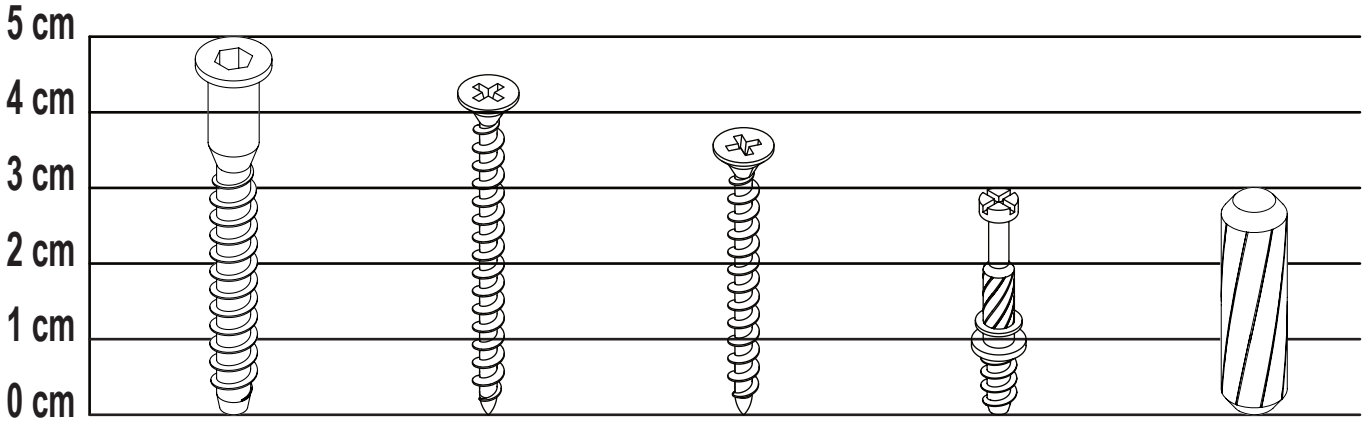

1x
M6.3 x 50mm
A
Unitar Screw

4x
M4 x 45mm
B
CSK Screw

24x
M4 x 38mm
C
CSK Screw

28x
EU 24
D
Minifix Bolt

47x
Dia. 8 x 30mm
E
Wooden Dowel

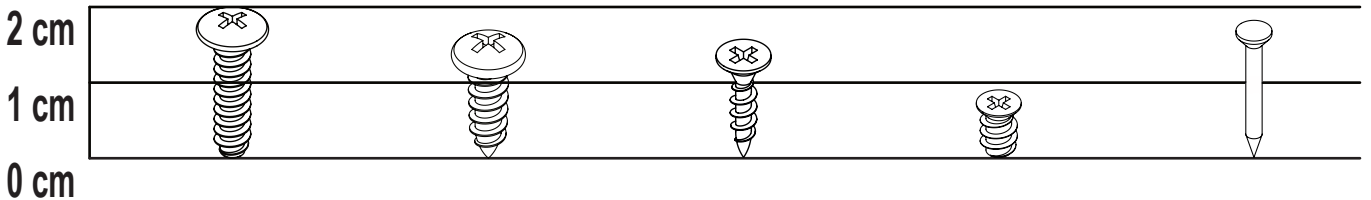

12x
M4 x 20mm
F
Handle Screw

2x
#10 x 16mm
G
Tapping
Screw

28x
M3.5 x 15mm
H
CSK Screw

24x
M6 x 8mm
I
Euro Screw

20x
J
Nail Pin

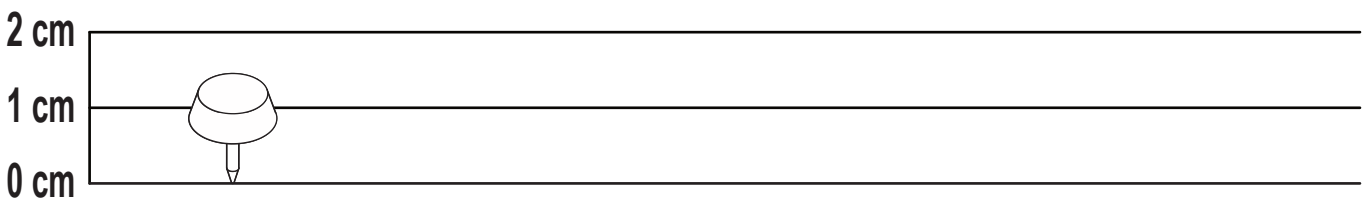

6x
K
Nail Leg

Fixings (not to scale)

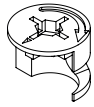

28x
Dia. 15 x 12mm
L
Minifix Cam

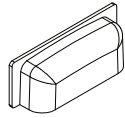

6x
H-32mm
M
Handle

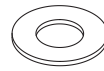

2x
D-16mm
N
Flat Washer

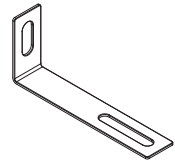

2x
1.2x15x32x75mm
O
L-Mounting
Bracket

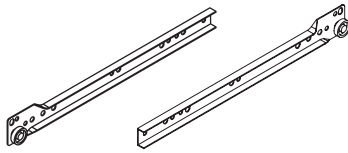

6 set x
12" (300mm)
P
Drawer Slide

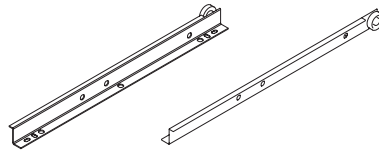

6 set x
12" (300mm)
Q
Drawer Slide

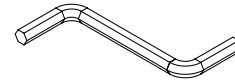

1x
M4
R
Allen Key

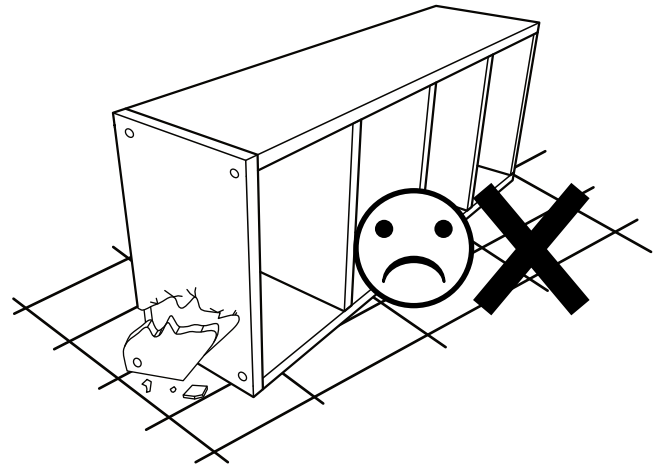
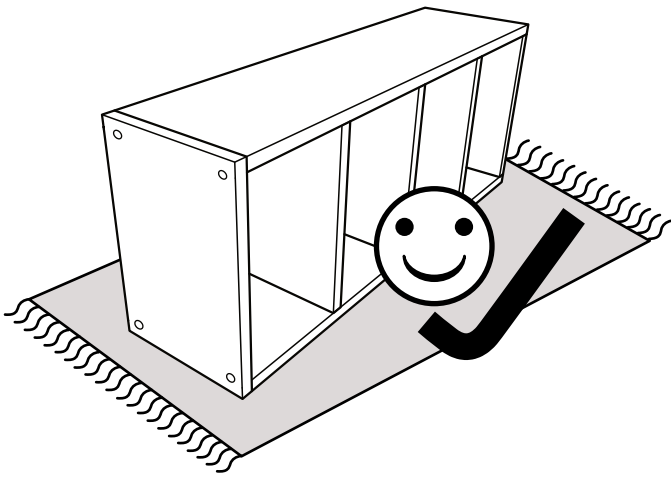

Layout Parts on Soft Surface

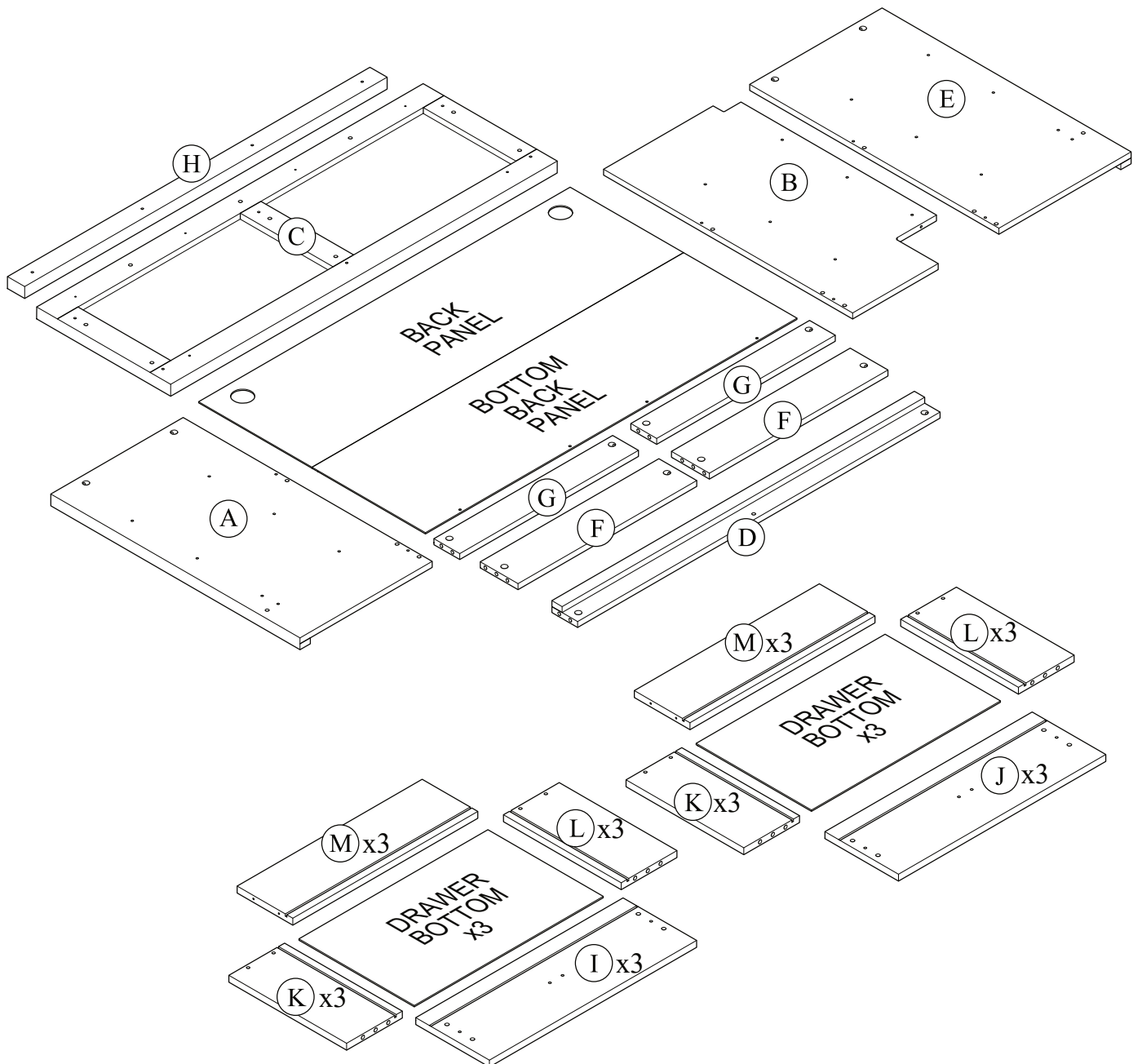

STEP 1

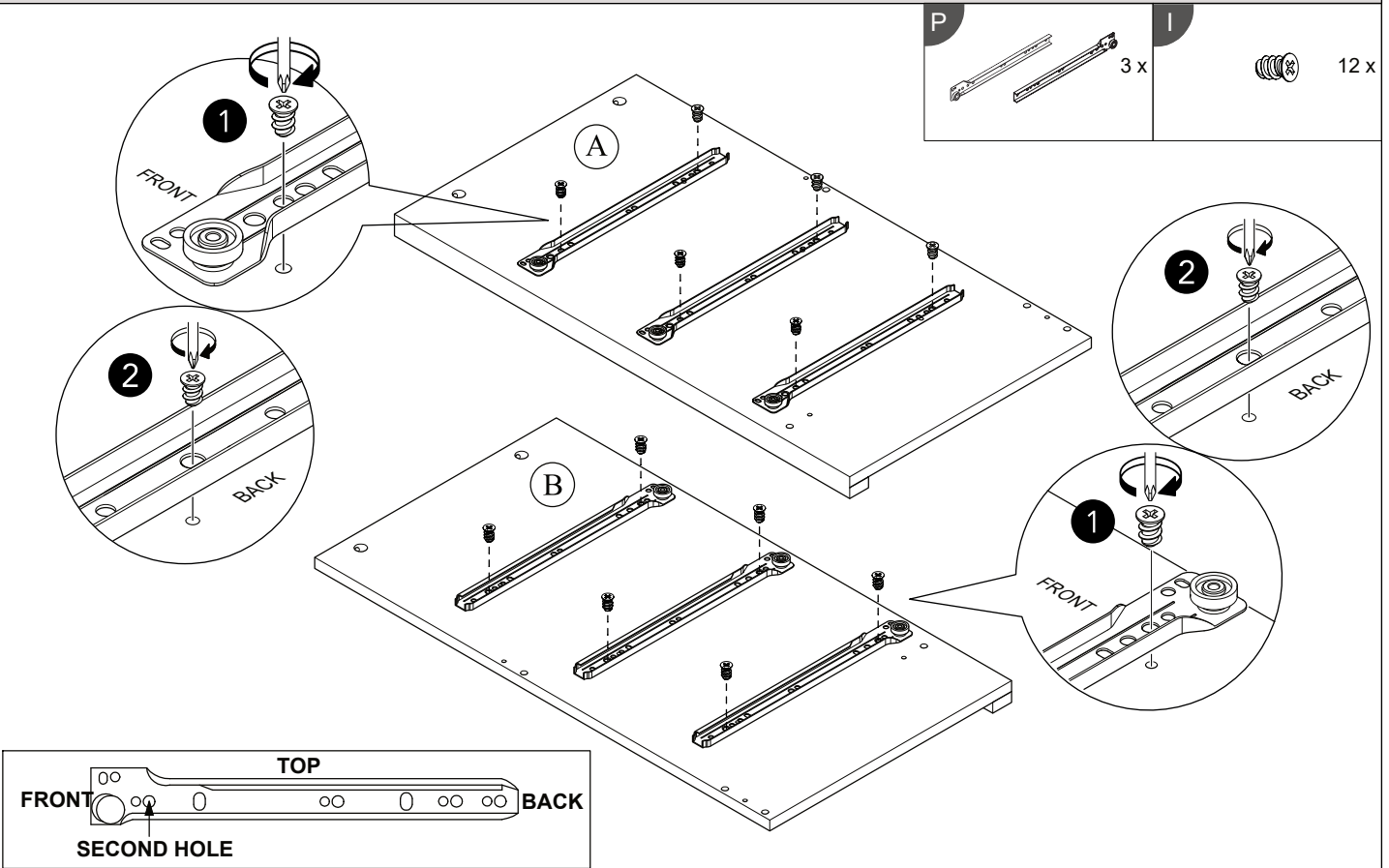

PLEASE ENSURE TO FIX THE SCREWS AS PER ABOVE POINTED HOLES INSTRUCTION TO AVOID DISTORTION OF OVERALL LOOK OF PRODUCTS

STEP 2

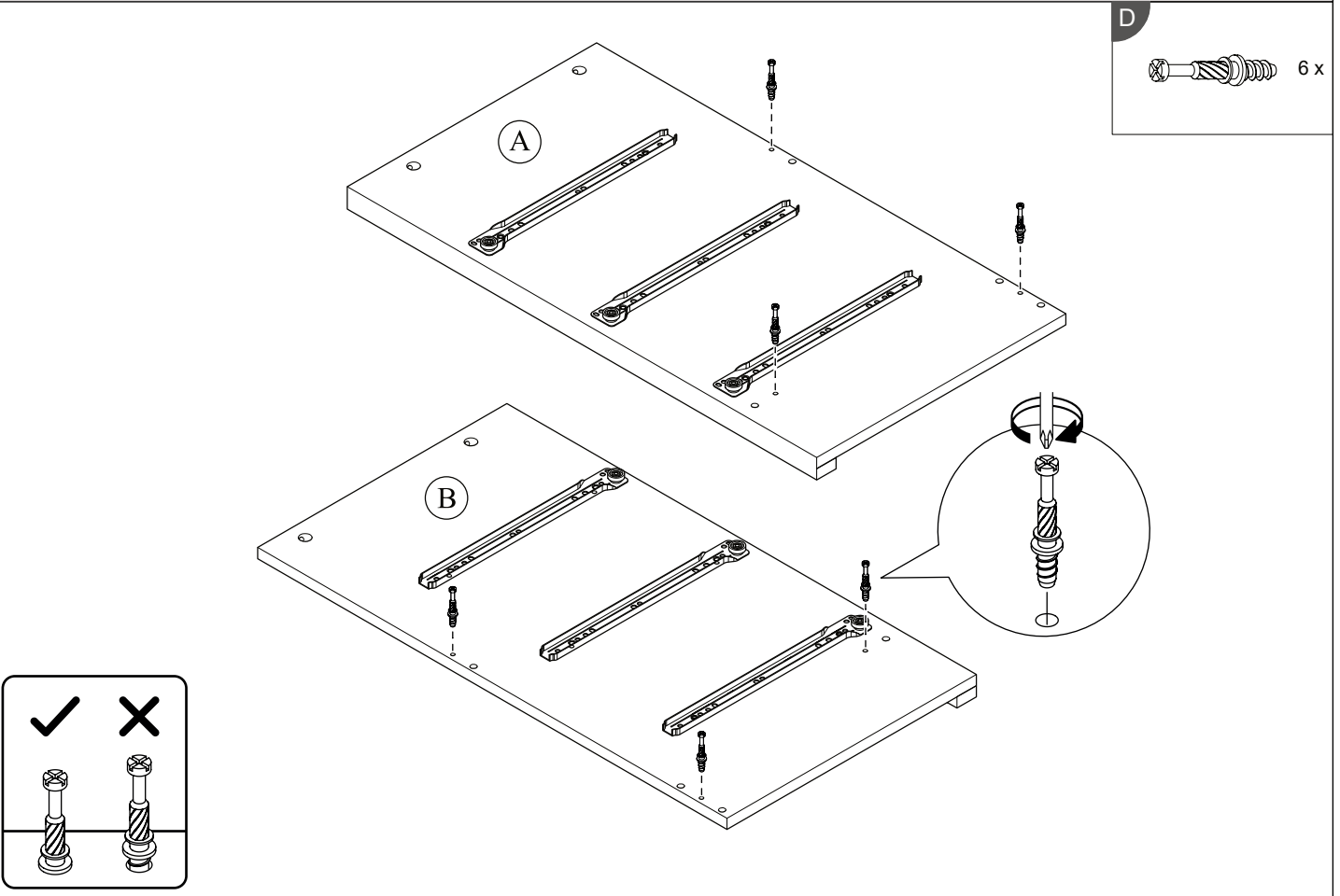

STEP 5

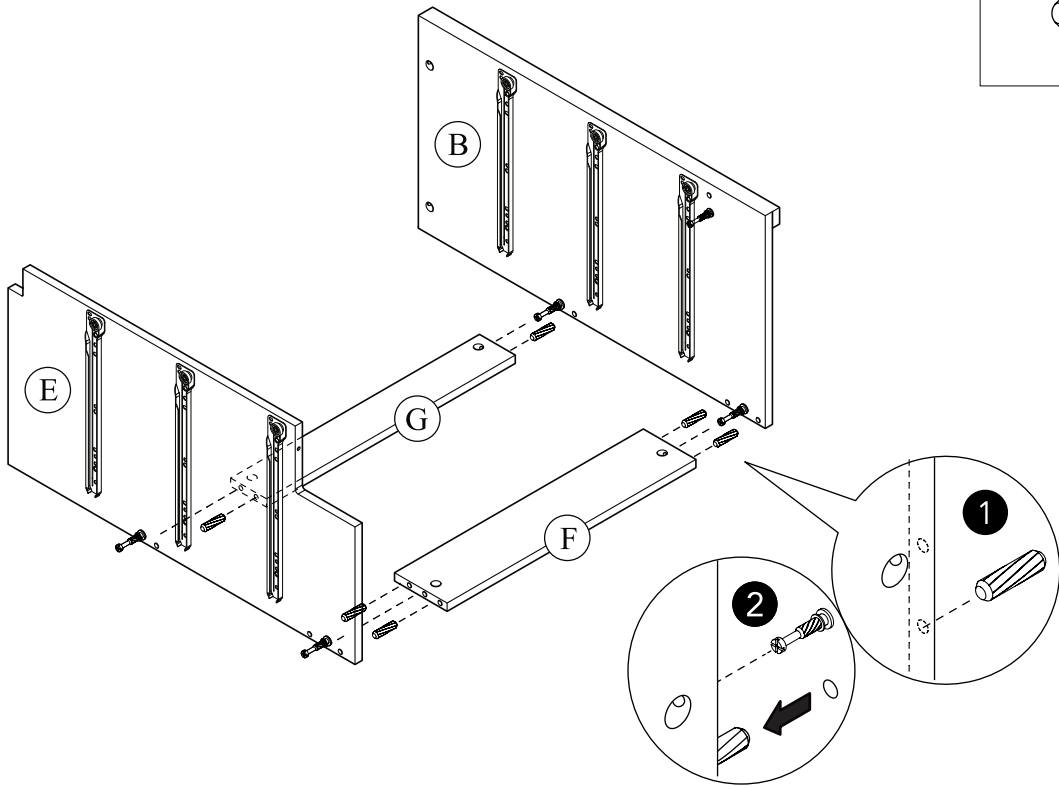
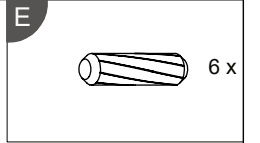

STEP 6

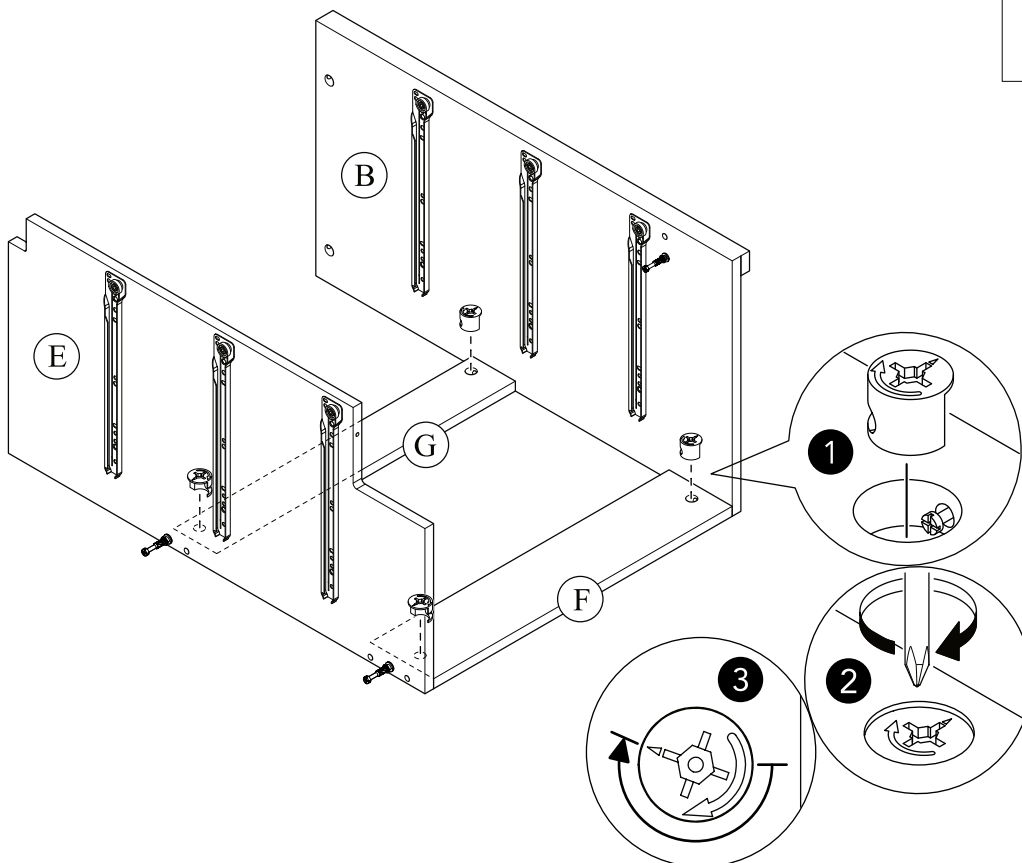
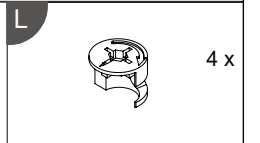

STEP 7

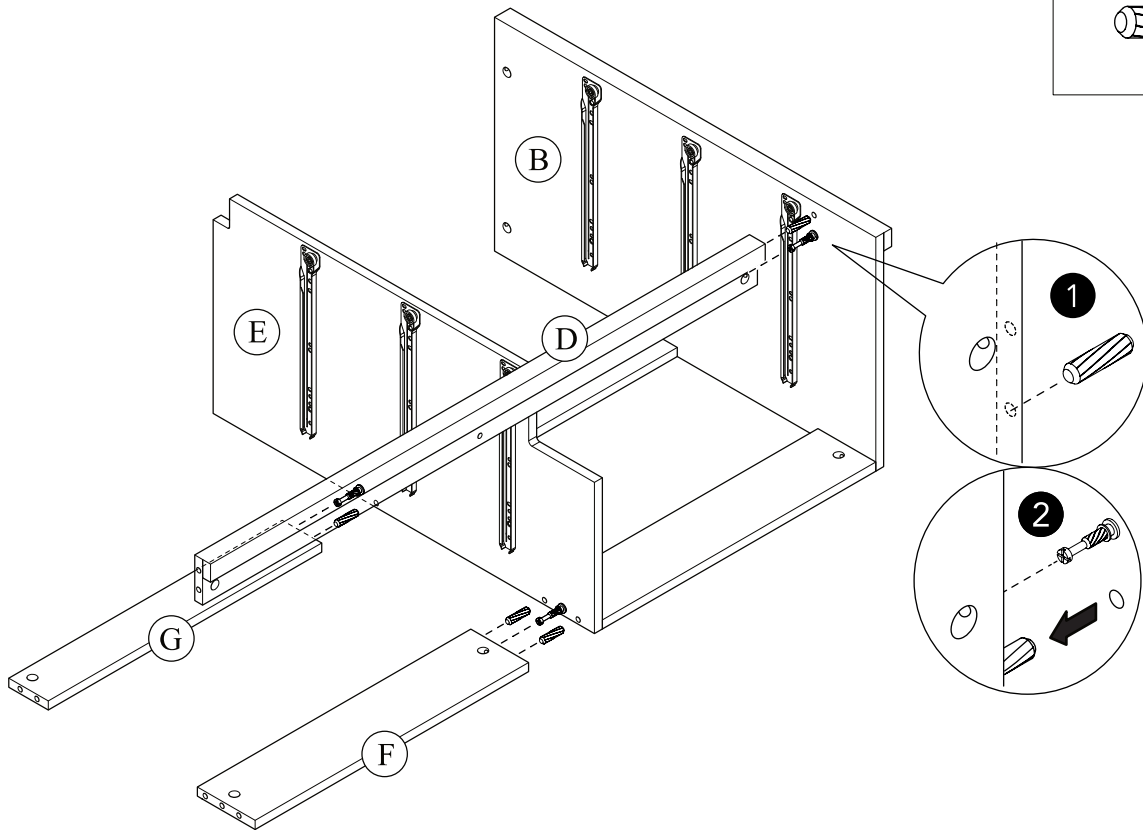

STEP 8

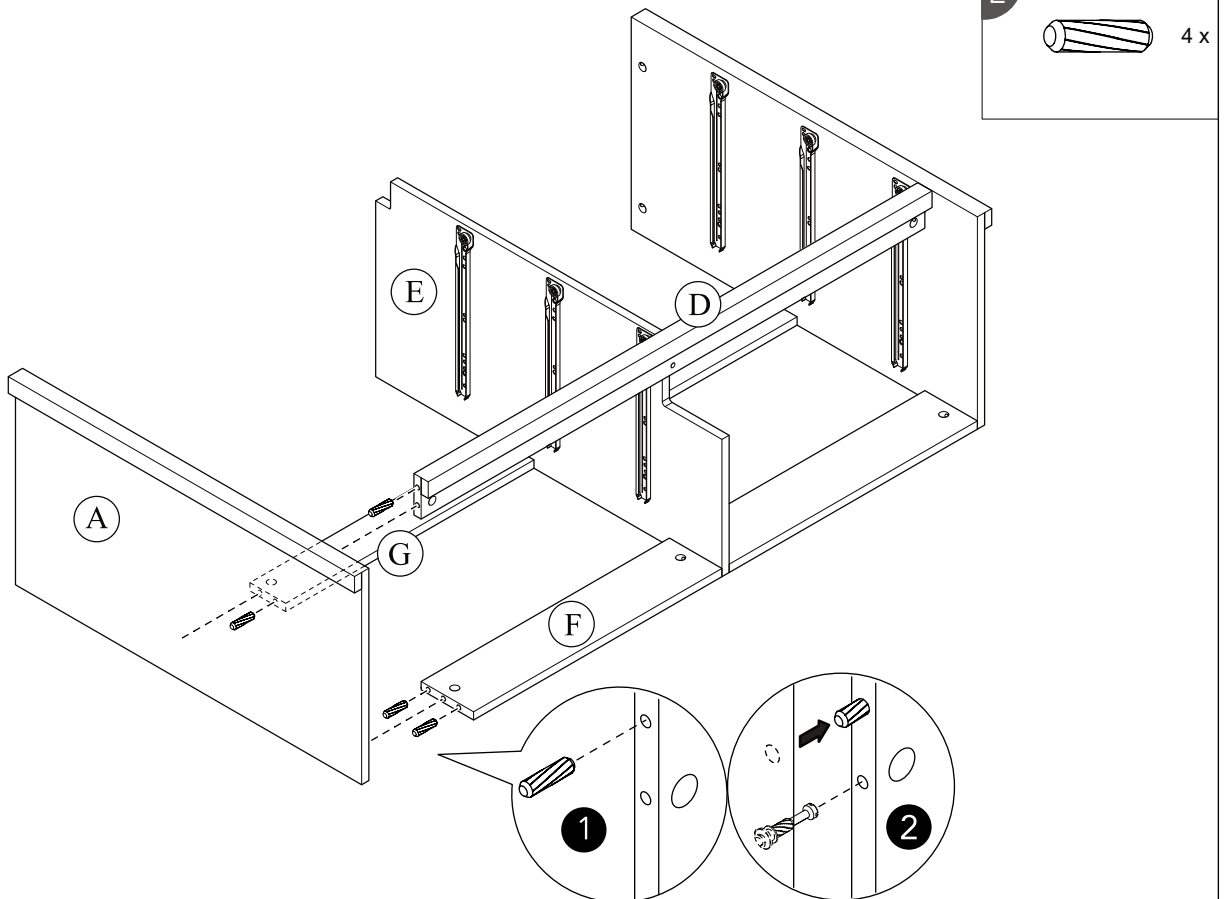

STEP 9

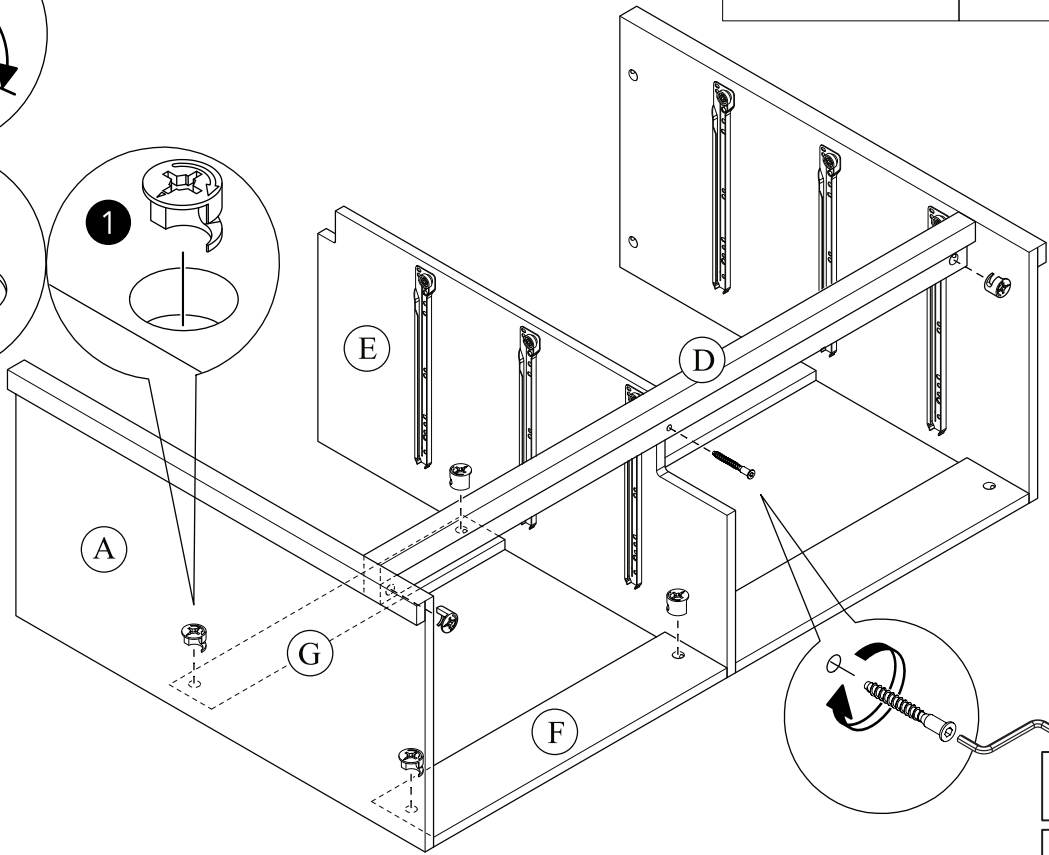
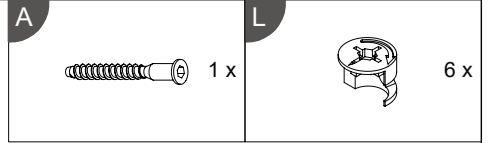
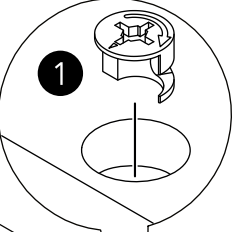
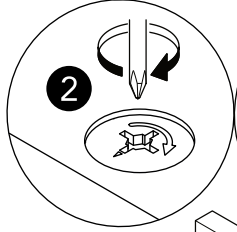
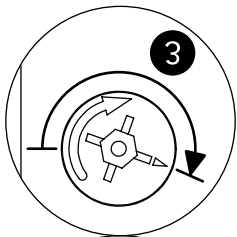

STEP 10

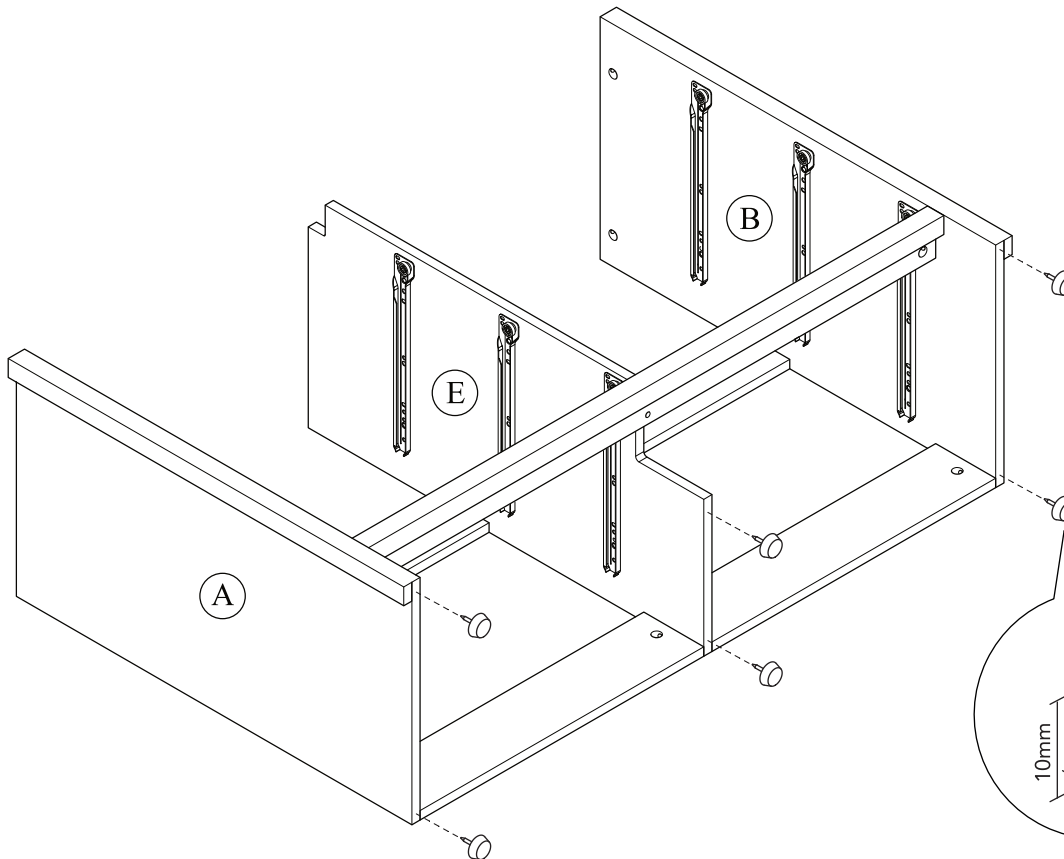
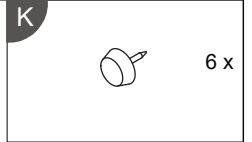

STEP 11

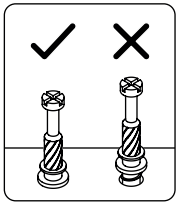
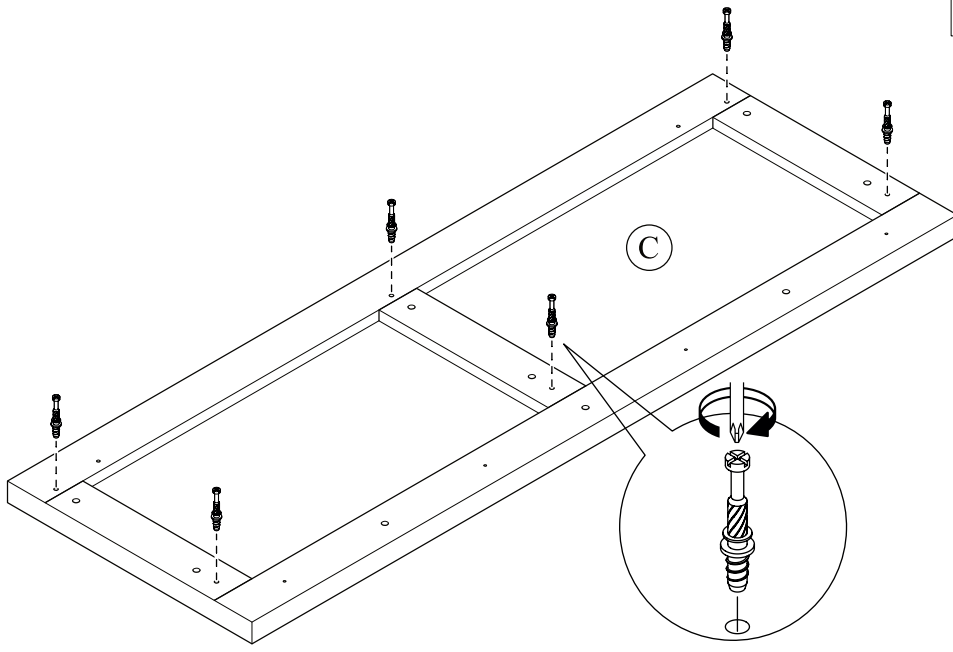
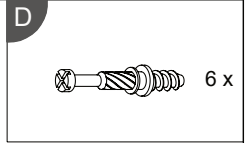

STEP 12

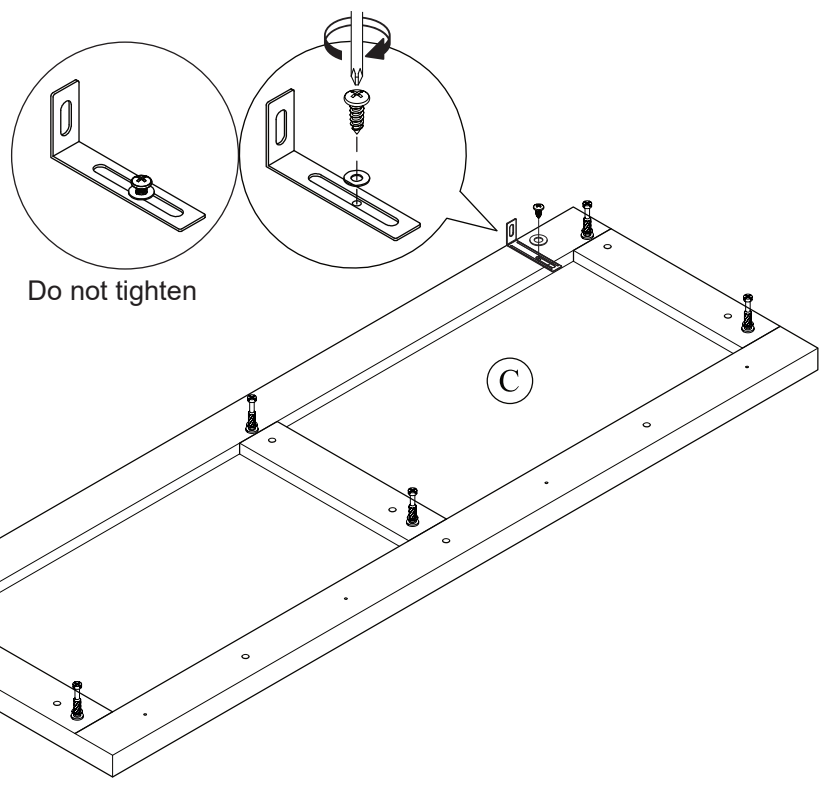
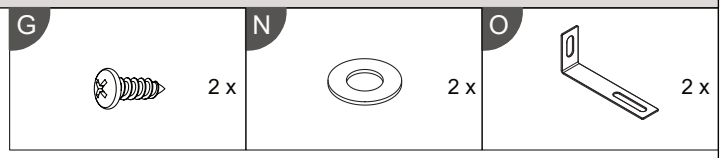

STEP 13

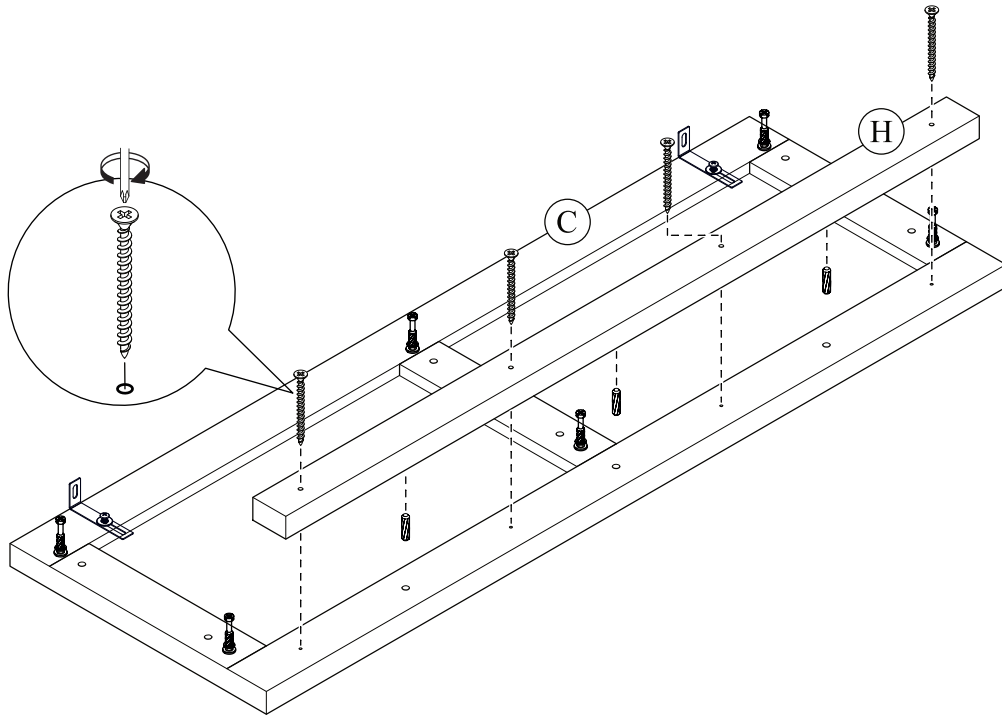
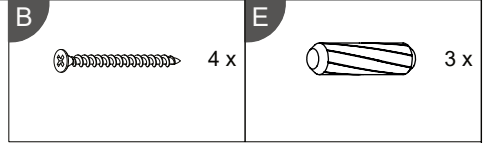

STEP 14

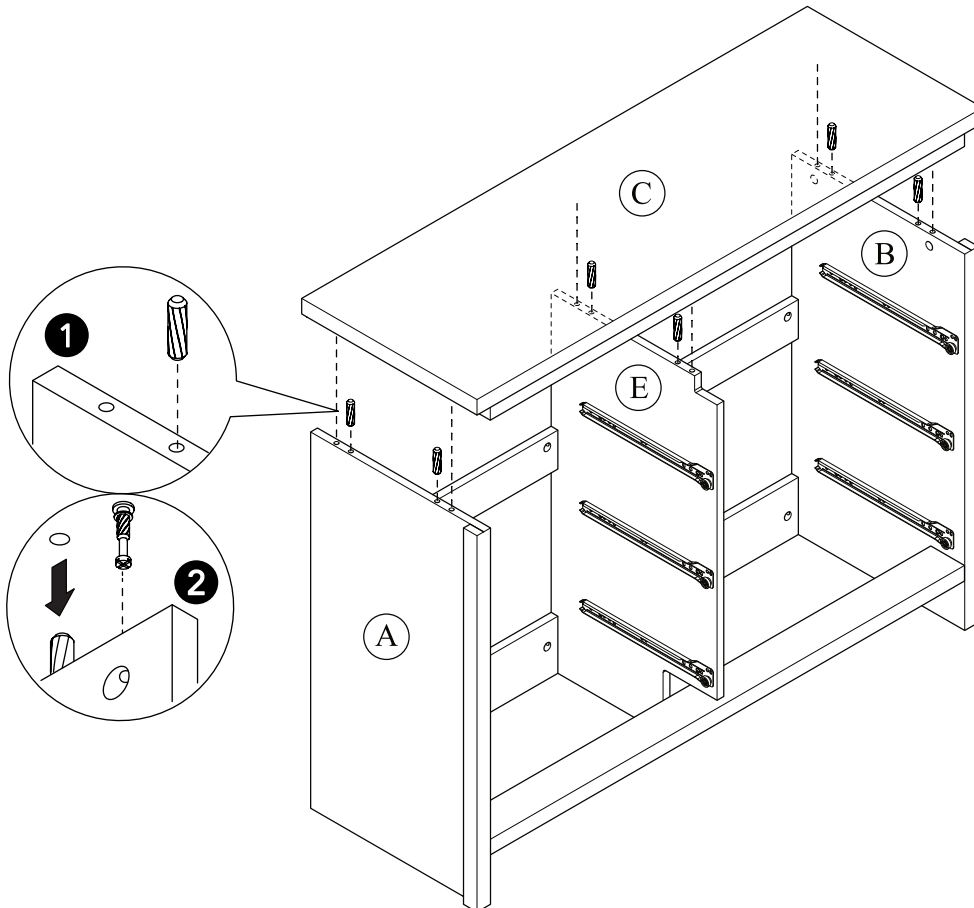
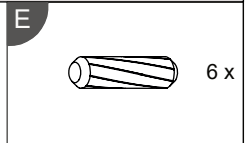

STEP 15

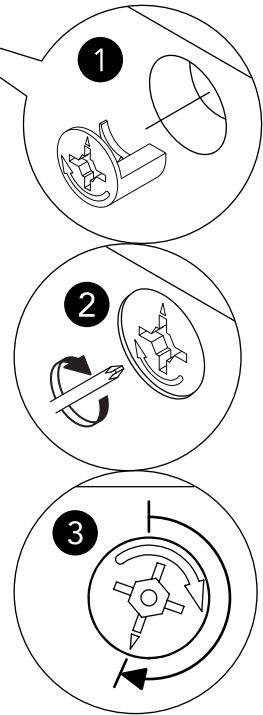
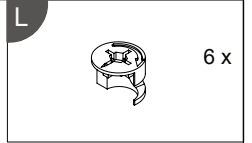
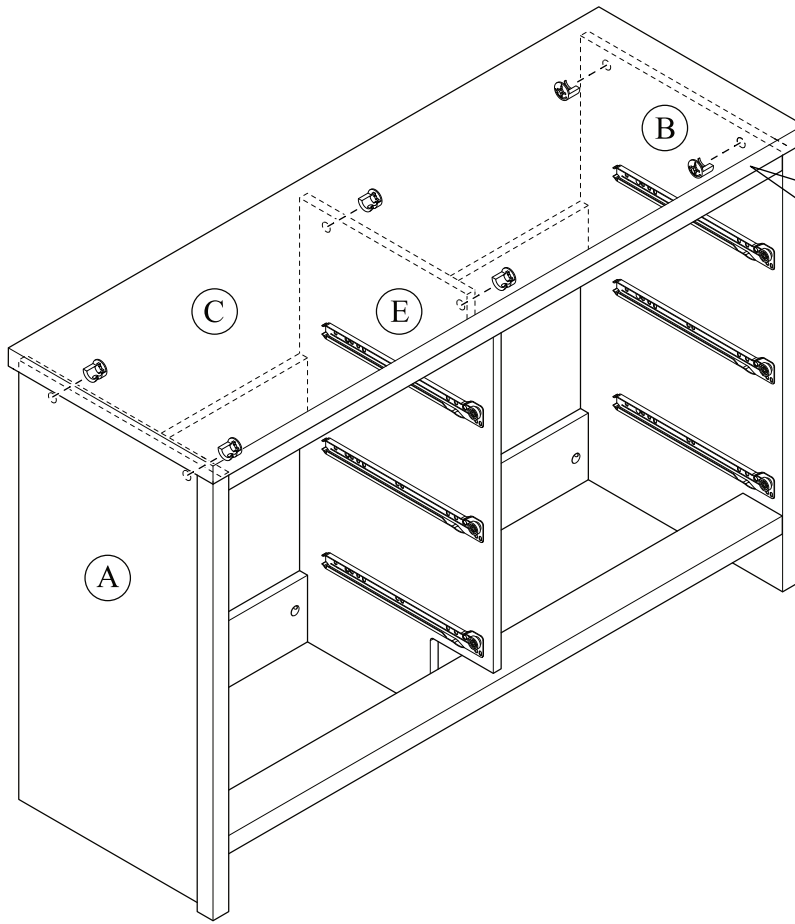

STEP 16

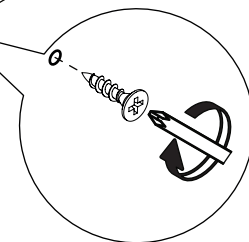
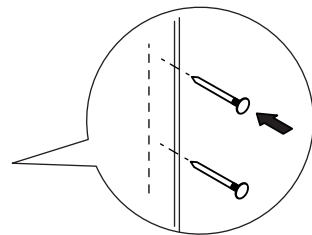
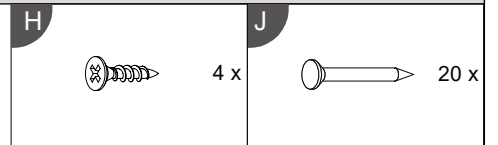
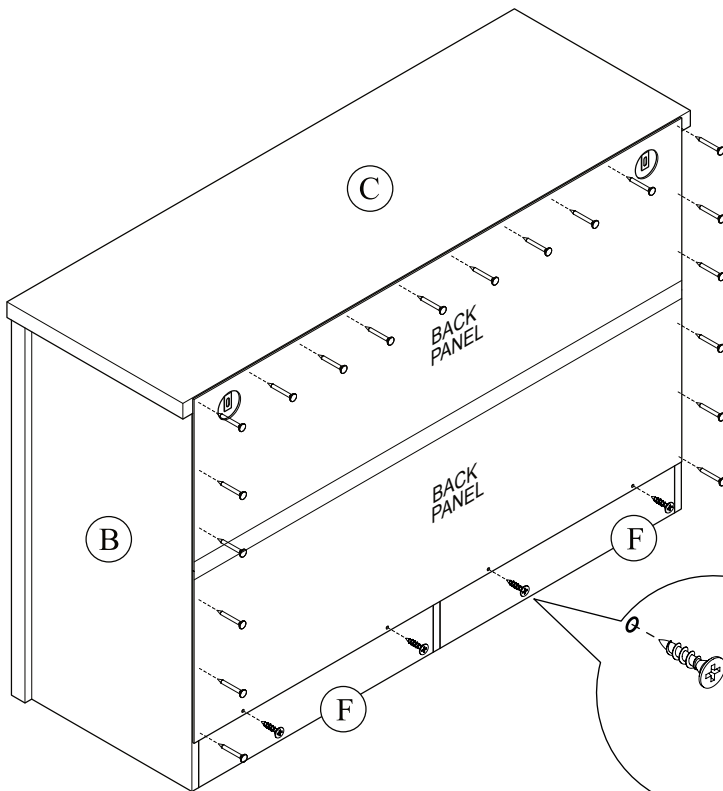

STEP 17

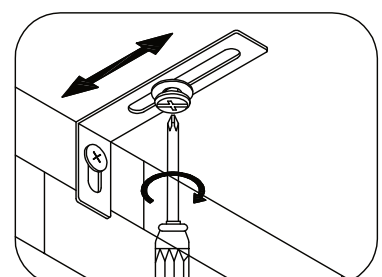
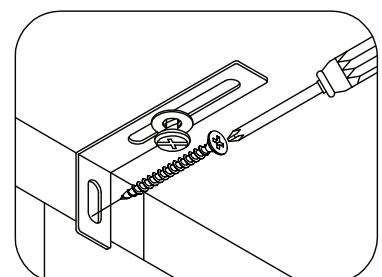
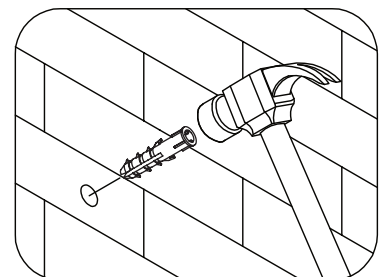
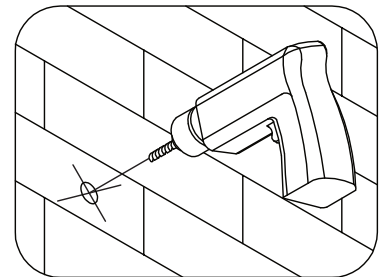
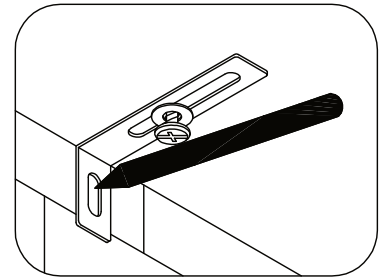
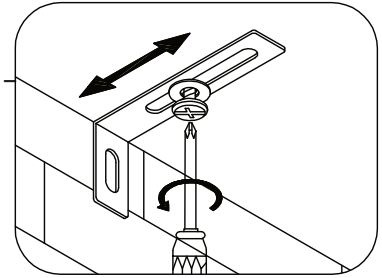
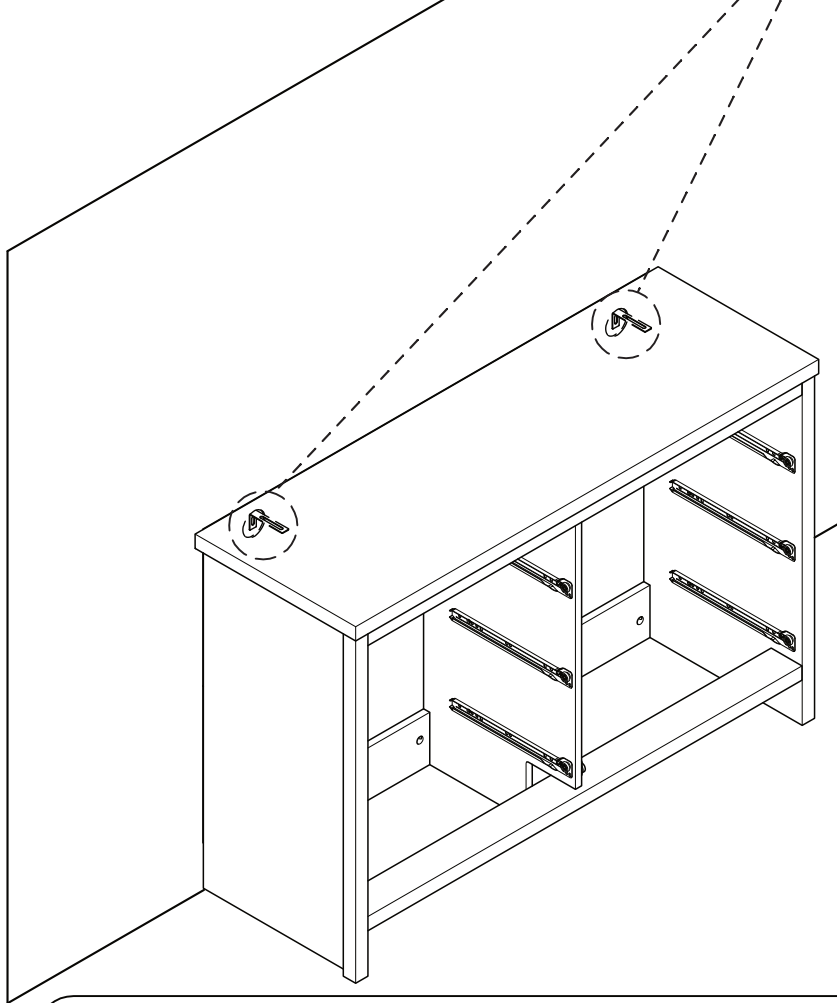
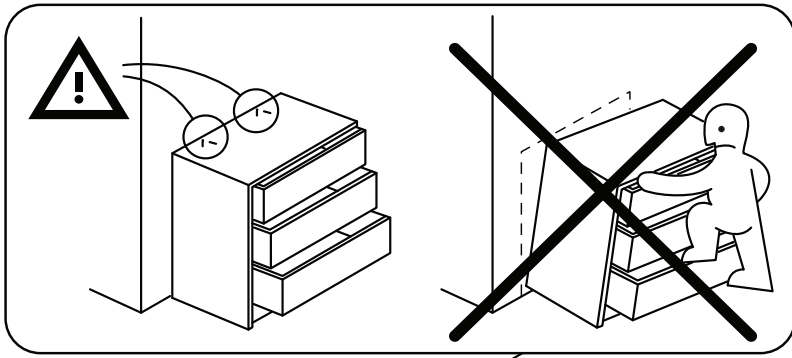

NOTE : Wall fixing are not supplied with this product as different wall materials require different types of fixing devices (such as Rawl plugs on brick work). You must use fixing devices suitable for the type of wall you intend to mount this product to. Please ensure that the head of any screw used has a diameter greater than the diameter of the mounting hole on the product and that the fixing is safe and secure before use.

The brackets and screws which to fix the strap on to the furniture are only supplied.

STEP 18

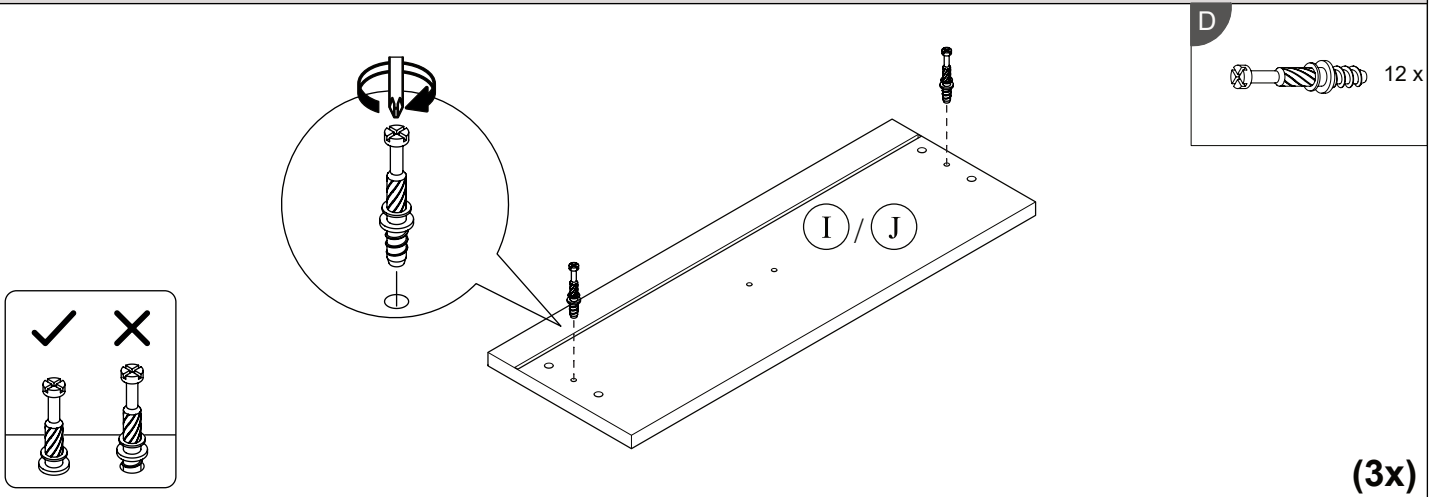

STEP 19

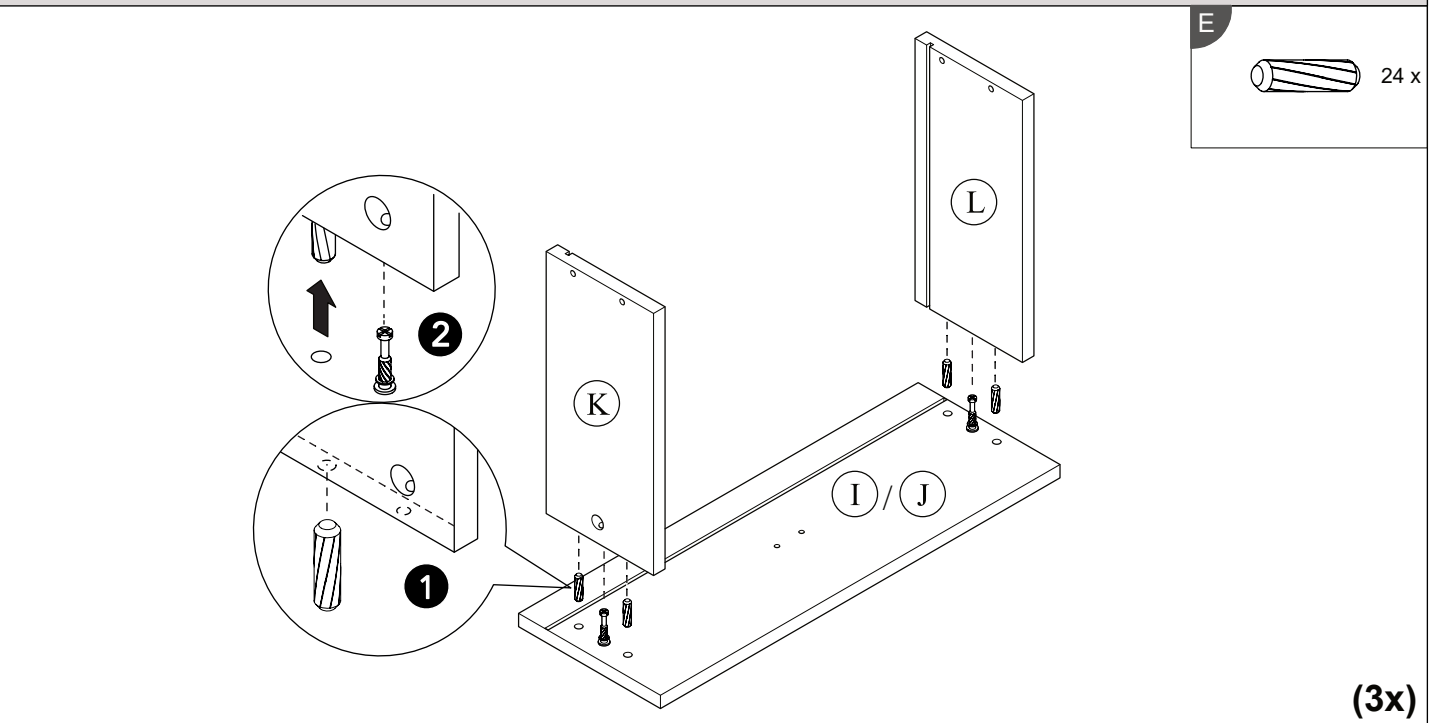

STEP 20

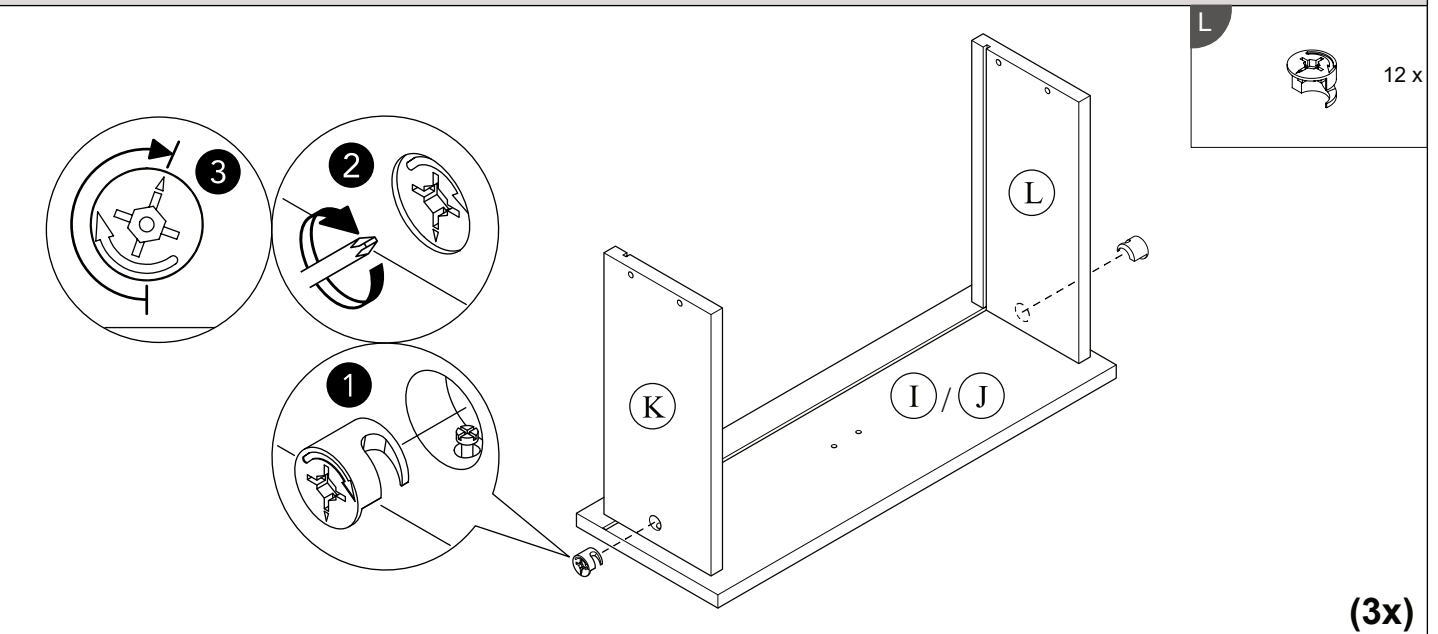

STEP 21

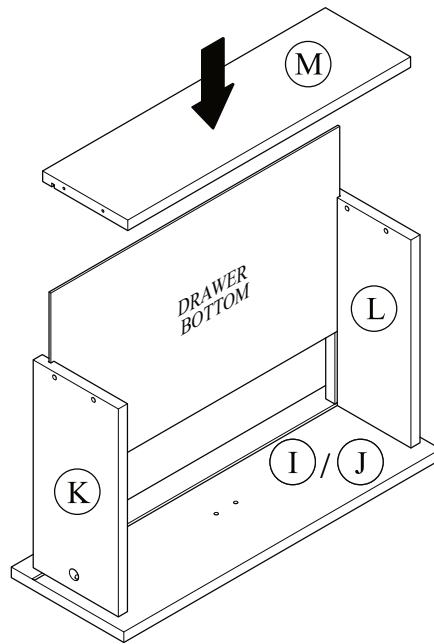

(3x)

STEP 22

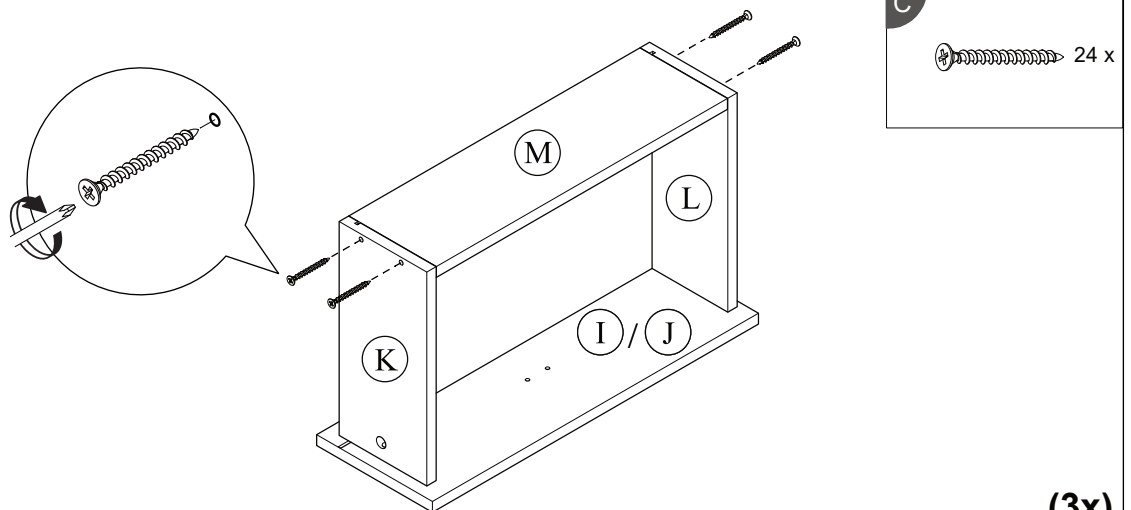

(3x)

STEP 23

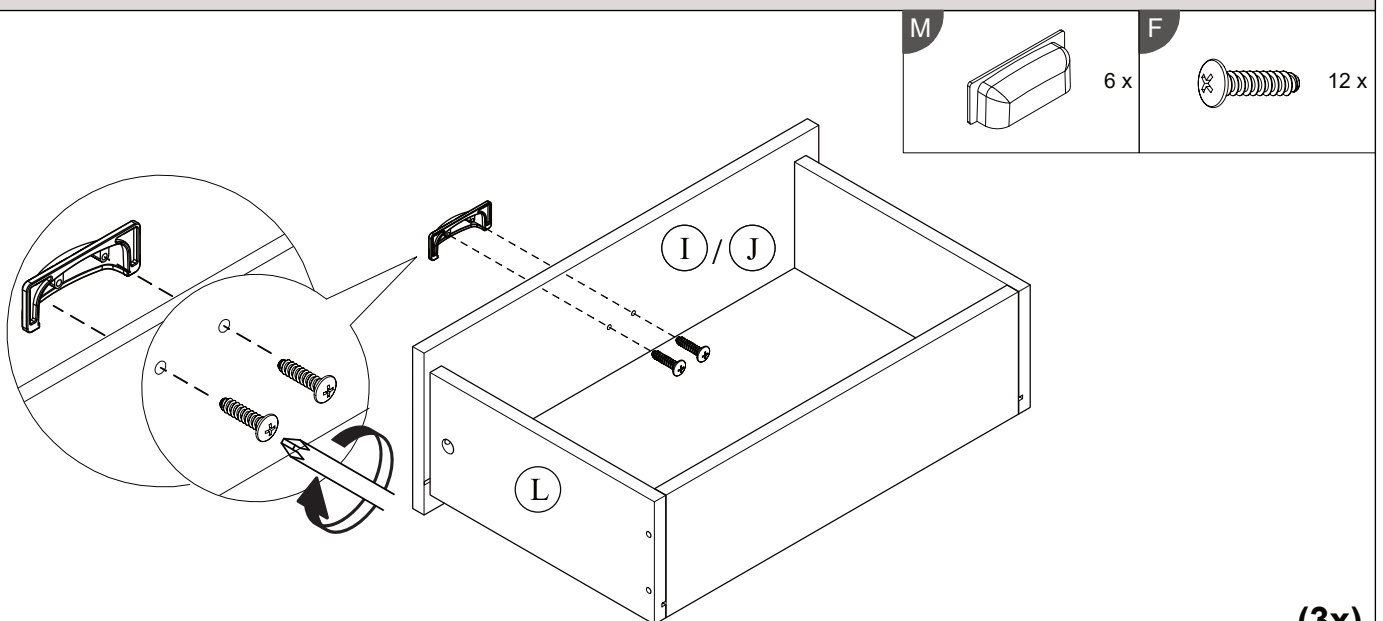

(3x)

STEP 24

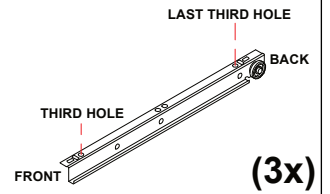
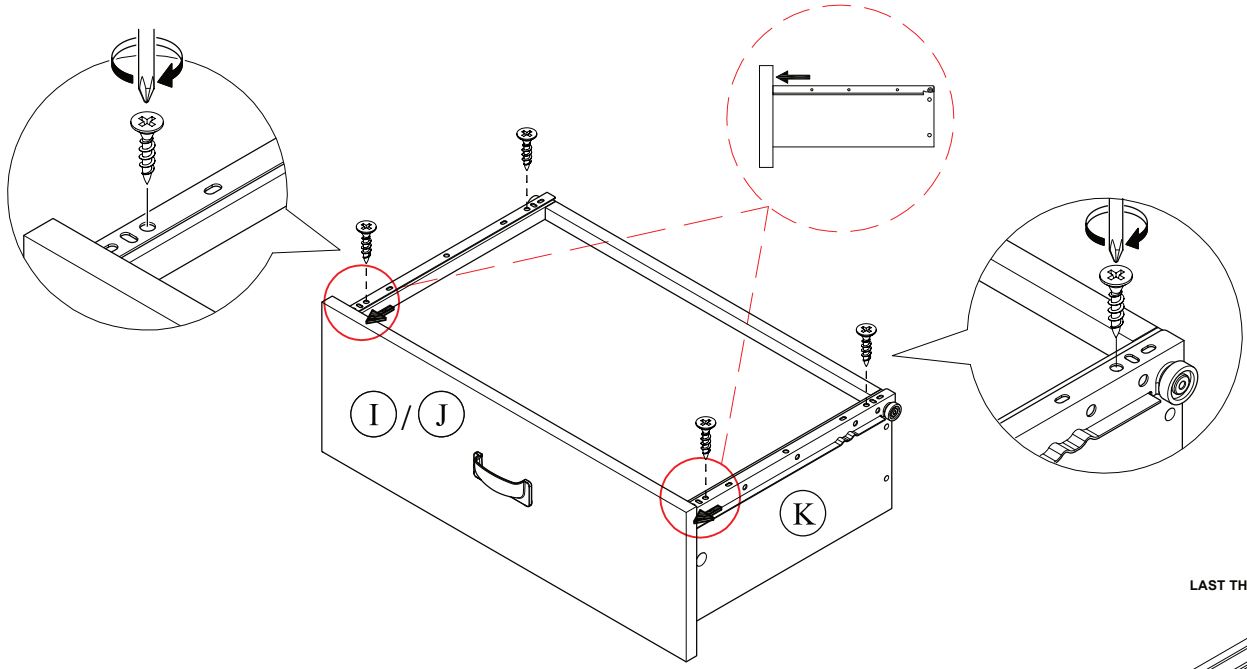
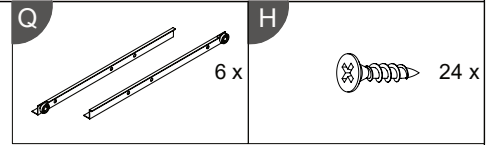

STEP 25

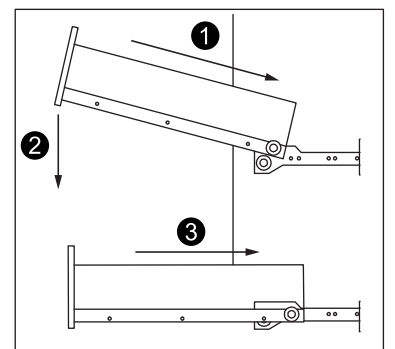
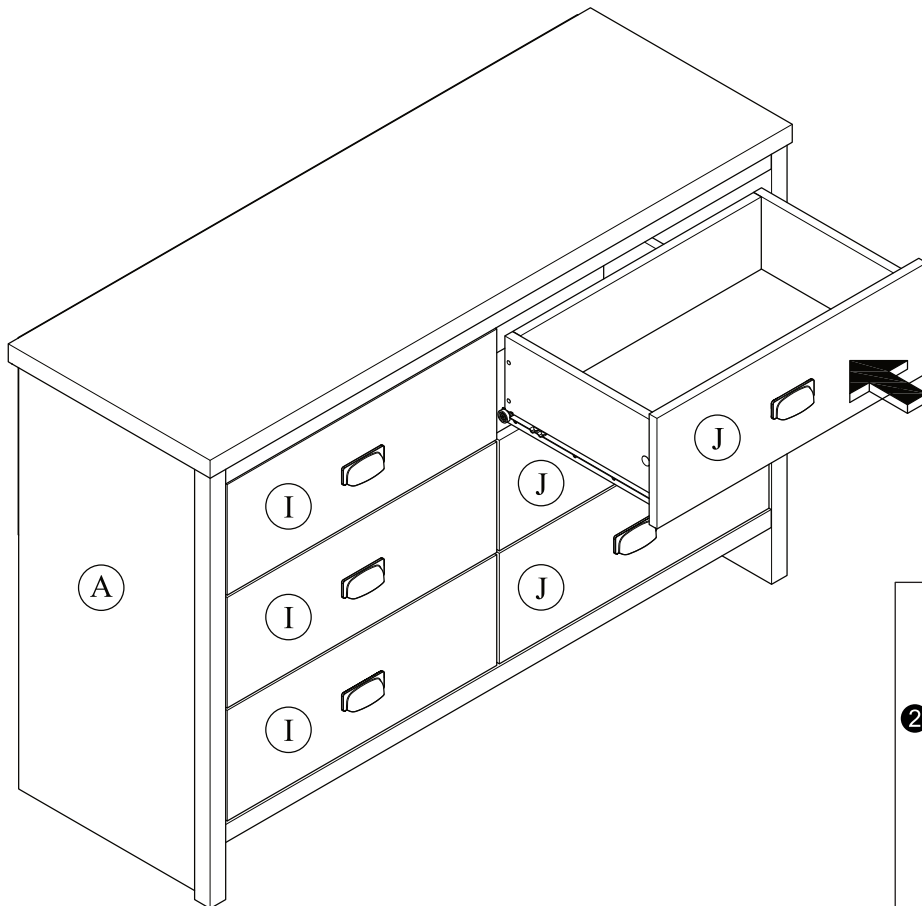

Complete Assembly

Your *INDUSTRIAL BOSTON 3+3 DRAWER CHEST* is now completely assembled.

Periodically check to ensure that the components are in their proper position, free from damage. Also, make sure the connectors are tight and secure.

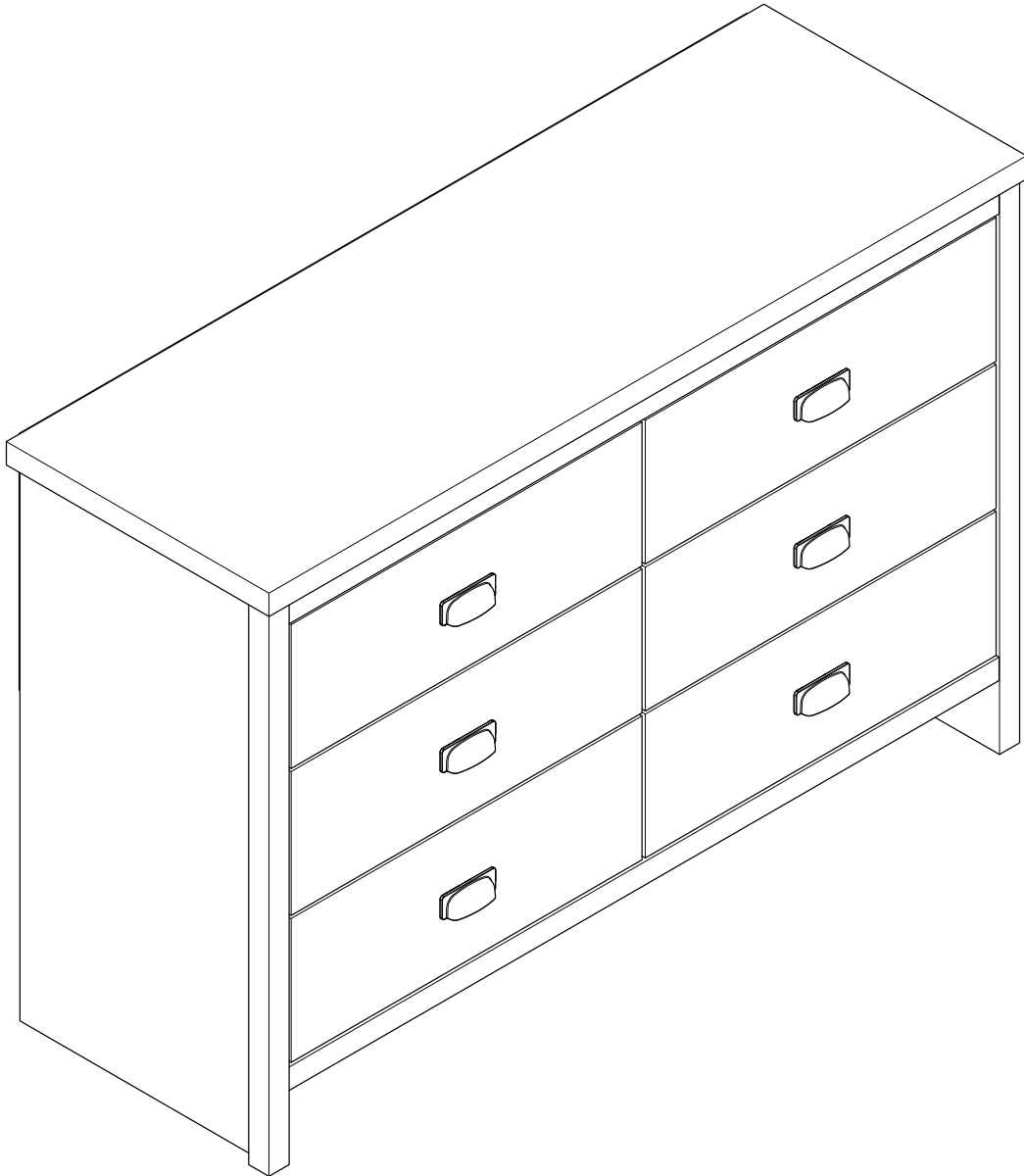

Keep instructions for future reference

