

MALVERN 8 DRAWER CHEST ASSEMBLY INSTRUCTIONS

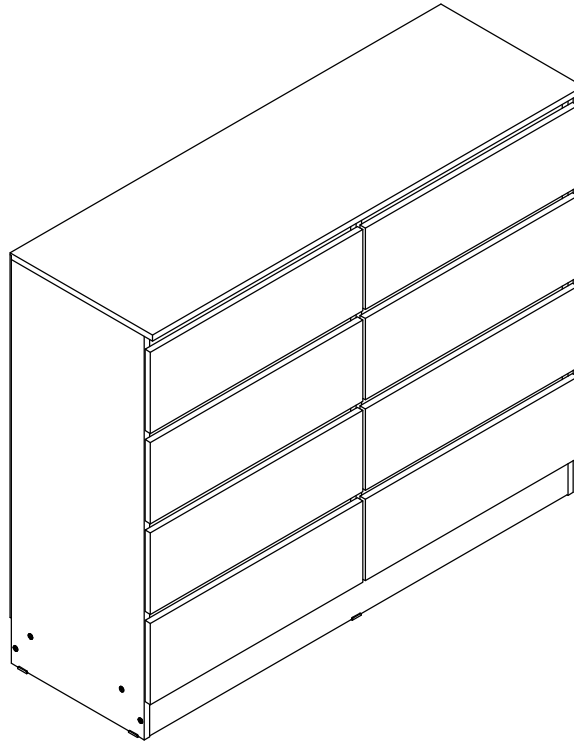

IMPORTANT FOR DOMESTIC USE ONLY PLEASE READ BEFORE YOU CONTINUE FURTHER

THE PRODUCT YOU HAVE PURCHASED WILL GIVE YOU MANY YEARS OF SERVICE IF YOU FOLLOW THE GUIDELINES FOR ITS SAFE ASSEMBLY AND PERIODIC MAINTENANCE AND CLEANING.

ASSEMBLE ON A SOFT CLEAN SURFACE.

DO NOT USE ANY TOOLS OTHER THAN THOSE SHOWN.

ANY SPANNERS OR ALLEN KEYS REQUIRED ARE INCLUDED WITH THE FITTINGS KIT.

DO NOT FOR ANY REASON USE A POWER TOOL TO ASSEMBLE THIS PRODUCT. ITS USE WILL INVALIDATE ANY CLAIM YOU MAY HAVE AND COULD MAKE THIS PRODUCT UNSAFE.

DEPENDING ON THE AMOUNT OF USE THIS PRODUCT RECEIVES IT MAY BE NECESSARY TO TIGHTEN UP THE FIXINGS FROM TIME TO TIME. THIS IS COMPLETELY NORMAL FOR ANY FLAT PACK FURNITURE. DO NOT OVERTIGHTEN FIXING.

FOR CLEANING, YOU MAY USE A DAMP CLOTH (NOT WET) DO NOT USE POLISH, DÉTERGENT OR CHEMICAL CLEANERS.



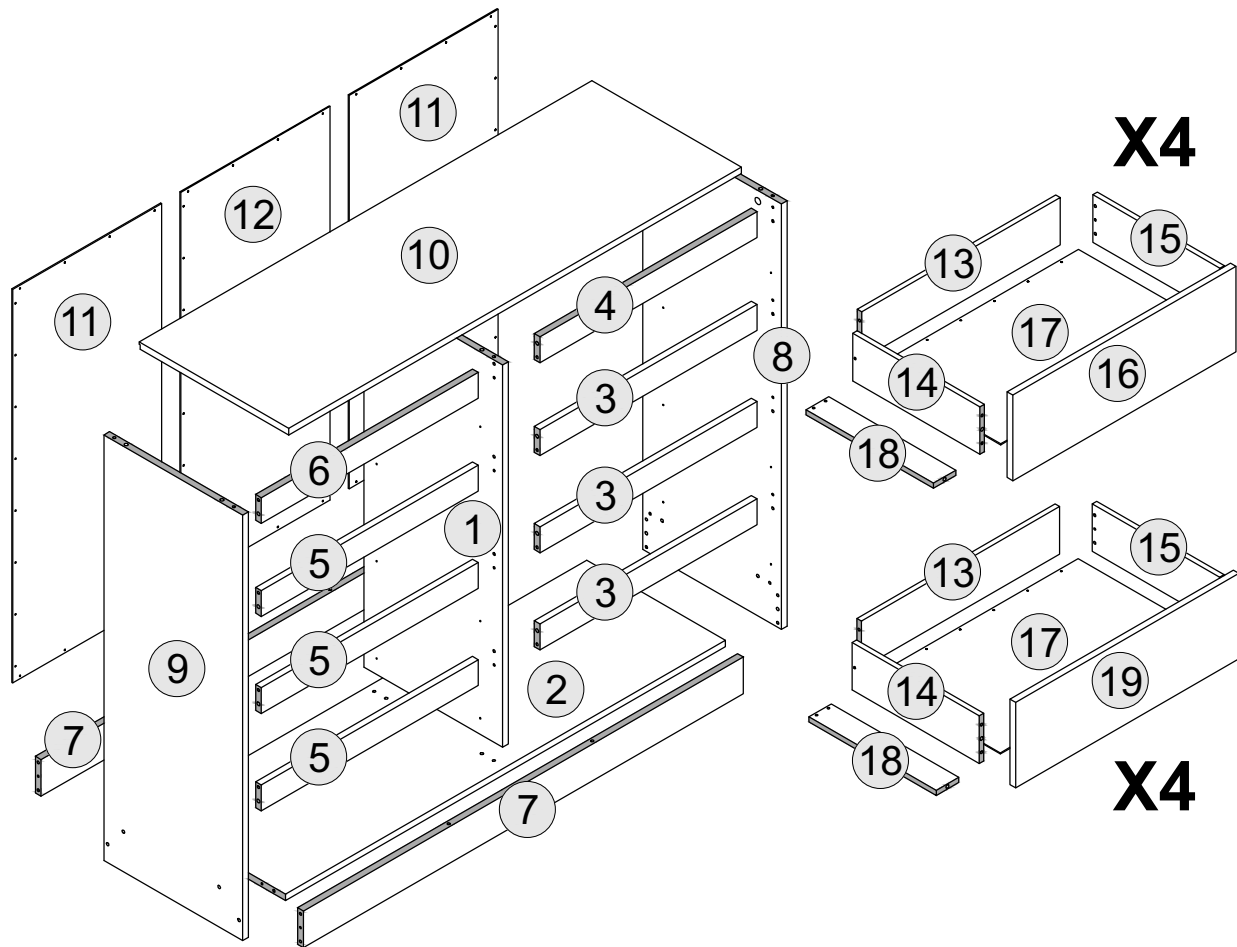













THE SURFACE OF THIS ITEM IS NOT HEAT RESISTANT. ALWAYS USE A PLACE MAT UNDER HOT OR COLD ITEMS TO PREVENT MARKING.



PART LIST

Part Number	Part Code	Part Description	Quantity	Carton
1	S100-102-167-EU1-01	Centre Panel	1	2/2
2	S100-102-167-EU1-02	Bottom Panel	1	1/2
3	S100-102-167-EU1-03	Crossbar - Right	3	1/2
4	S100-102-167-EU1-04	Top Crossbar - Right	1	1/2
5	S100-102-167-EU1-05	Crossbar - Left	3	1/2
6	S100-102-167-EU1-06	Top Crossbar - Left	1	1/2
7	S100-102-167-EU1-07	Base Apron	2	1/2
8	S100-102-167-EU1-08	Side Panel - Right	1	2/2
9	S100-102-167-EU1-09	Side Panel - Left	1	2/2
10	S100-102-167-EU1-10	Top Panel	1	1/2
11	S100-102-167-EU1-11	Back Panel	2	1/2
12	S100-102-167-EU1-12	Back Panel - Centre	1	1/2
13	S100-102-167-EU1-13	Drawer Back	8	2/2
14	S100-102-167-EU1-14	Drawer Side - Left	8	2/2
15	S100-102-167-EU1-15	Drawer Side - Right	8	2/2
16	S100-102-167-EU1-16	Drawer Front - Left	4	1/2
17	S100-102-167-EU1-17	Drawer Base	8	2/2
18	S100-102-167-EU1-18	Drawer Bottom Support Rail	8	2/2
19	S100-102-167-EU1-19	Drawer Front - Right	4	1/2

HARDWARE LIST

A		DOWEL 6 X 30MM	104 PCS
B		ALLEN KEY	1 PC
C		BOLT M6 X 50MM	8 PCS
D		SCREW M3.5 X 16MM	54 PCS
E		TACK	40 PCS
F		PLASTIC FOOT	6 PCS
G		SCREW M3.5 X 12MM	112 PCS
H		CAM BOLT + CAM NUT	46 SETS
I		DRAWER RUNNER A - L/R	16 PCS
J		DRAWER RUNNER B - L/R	16 PCS
K		SCREW M4 X 38MM	16 PCS
L		PLASTIC H STRIP	2 PCS
M		SCREW M4 X 25MM	16 PCS
N		SCREW M6 X 50MM	2 PCS
O		ANTI - TIP STRAP	2 PCS
P		SCREW M4 X 16MM	2 PCS

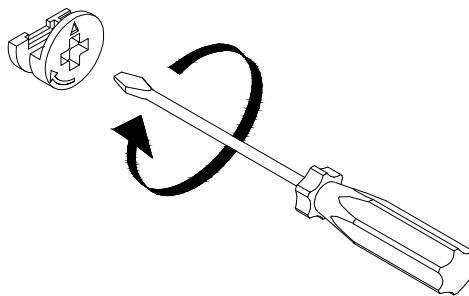

(SCREWDRIVER NOT PROVIDED)

USE A FLAT HEAD SCREWDRIVER TO TIGHTEN THE CAM NUTS. A QUARTER TURN CLOCKWISE IS ALL THAT IS NEEDED.

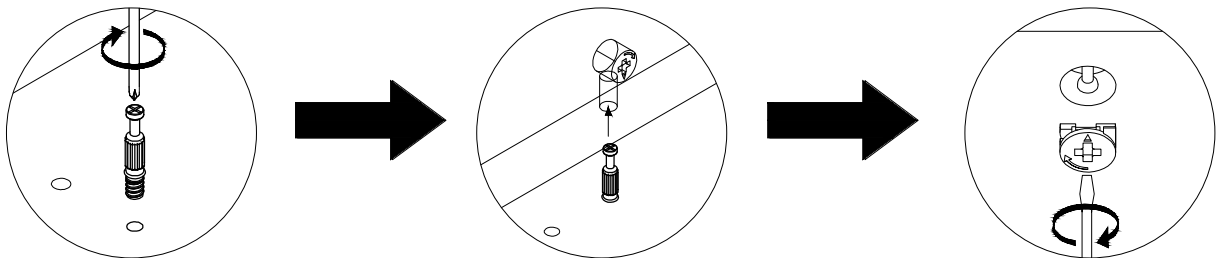

STEP 1 - USE A CROSS SLOT SCREWDRIVER TO TIGHTEN THE CAM BOLT INTO THE HOLE.

STEP 2 - ALIGN THE CAM BOLT WITH THE HOLE AND PUSH TOGETHER UNTIL FLUSH. (MAKE SURE THE ARROW OF THE CAM LOCK IS POINTING TOWARD ON THE EDGE OF THE PANEL.)

STEP 3 - THE HEAD OF THE BOLT GOES INTO THE WIDE MOUTH OF THE CAM LOCK. YOU THEN TURN THE LOCK SO THE NARROW PART CLOSES OVER THE BOLT.

STEP 1

PARTS REQUIRED

1 - CENTRE PANEL x1

HARDWARE REQUIRED

G  16

H  04

I  04

TOOLS REQUIRED

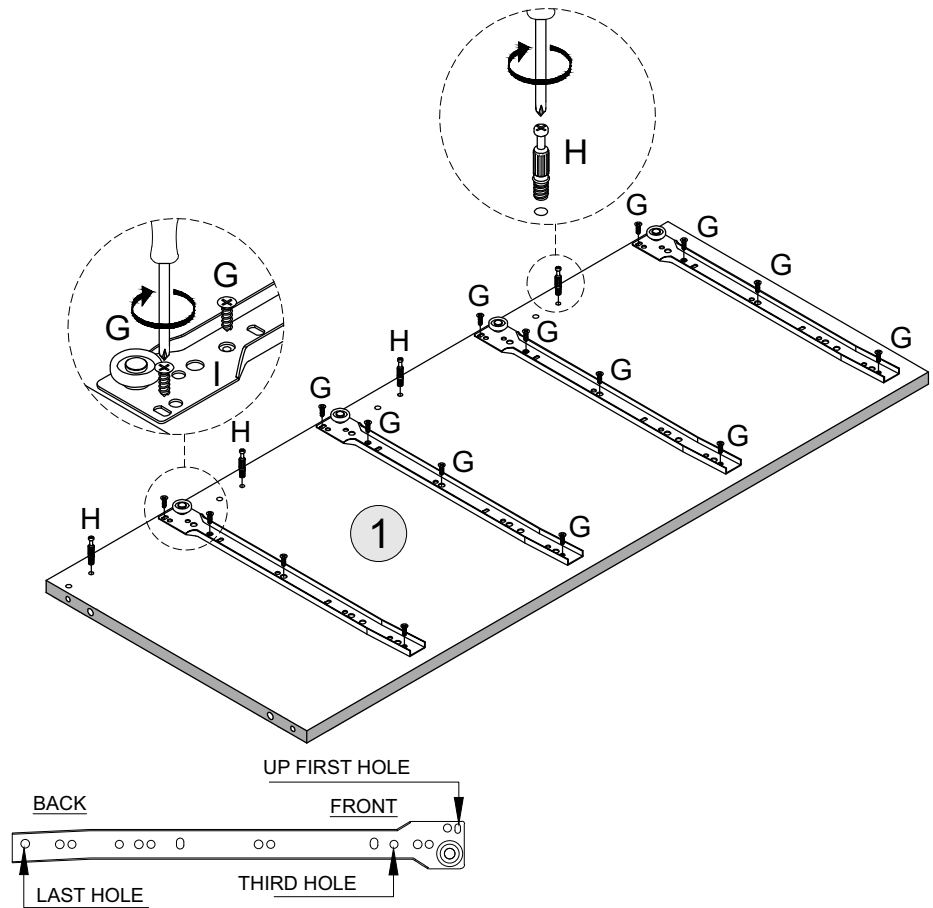
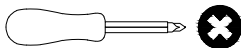

STEP 2

PARTS REQUIRED

1 - CENTRE PANEL x1

HARDWARE REQUIRED

A  04

G  16

H  04

H  02

I  04

TOOLS REQUIRED

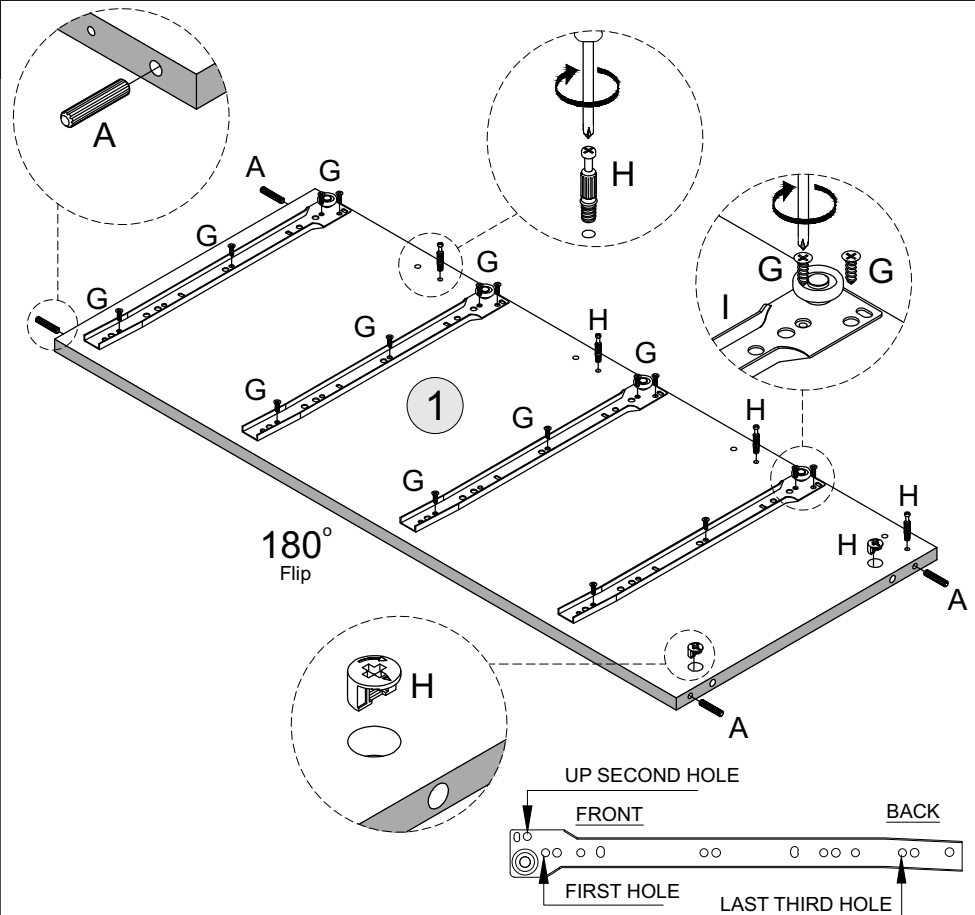
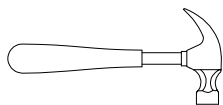
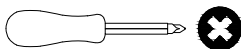

STEP 3

PARTS REQUIRED

9 - SIDE PANEL - LEFT x1

HARDWARE REQUIRED

A  02

G  16

H  04

H  02

I  04

TOOLS REQUIRED

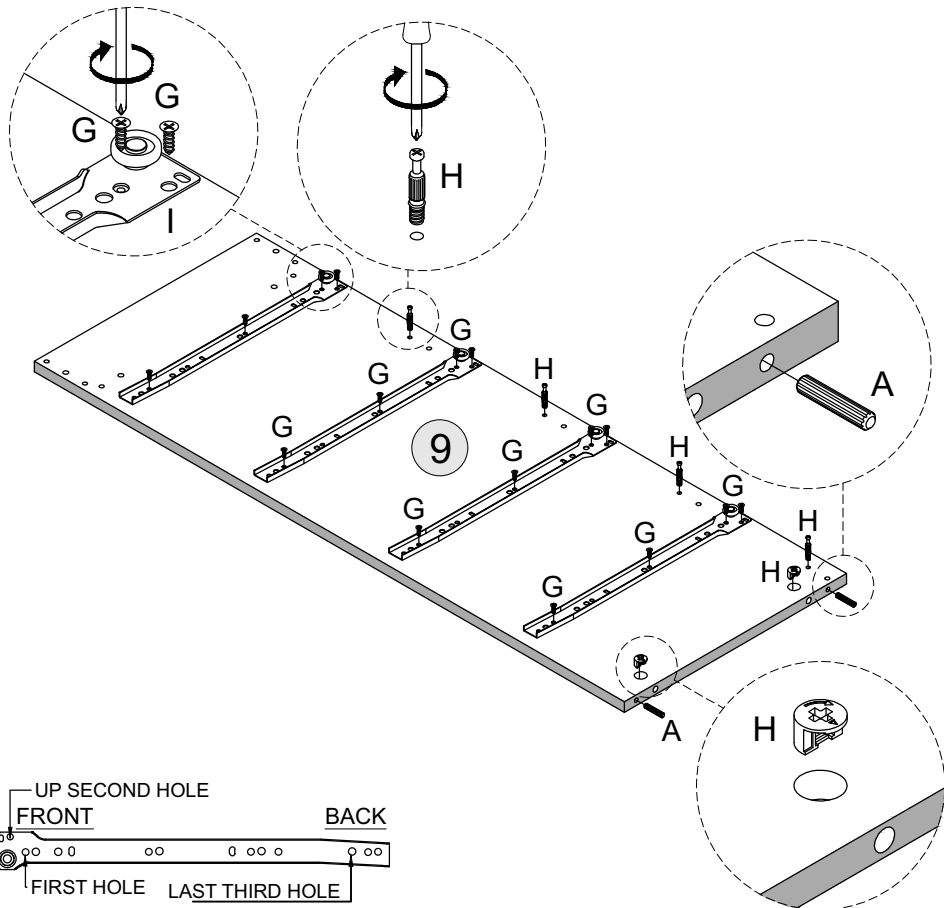
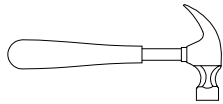
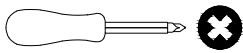

STEP 4

PARTS REQUIRED

8 - SIDE PANEL - RIGHT x1

HARDWARE REQUIRED

A  02

G  16

H  04

H  02

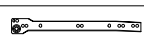
I  04

TOOLS REQUIRED

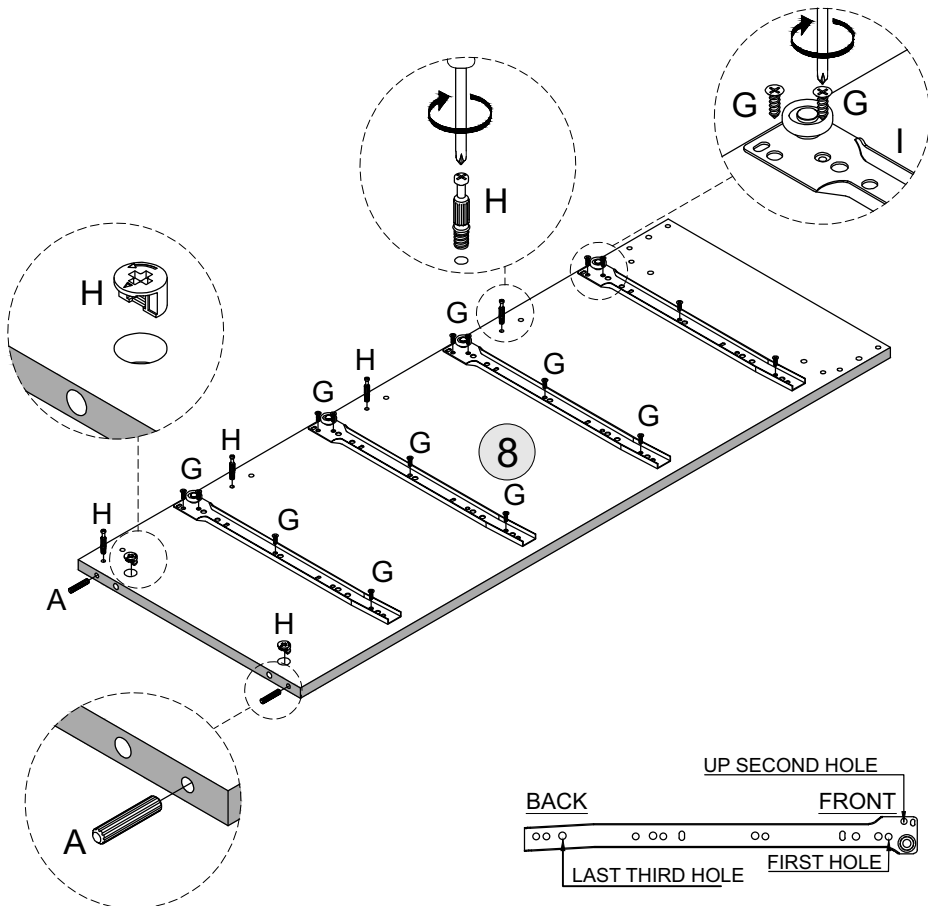
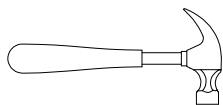
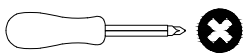



STEP 5

PARTS REQUIRED

2 - BOTTOM PANEL	x1
10 - TOP PANEL	x1

HARDWARE REQUIRED

A		04
H		06

TOOLS REQUIRED

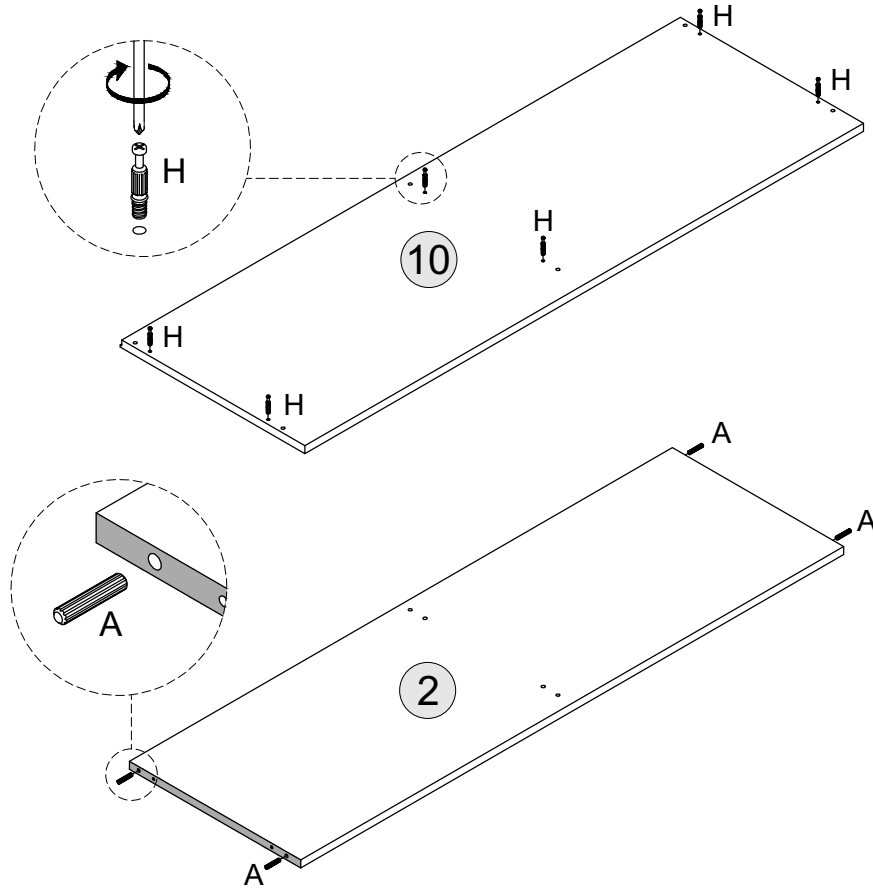
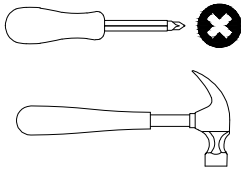



STEP 6

PARTS REQUIRED

3 - CROSSBAR - RIGHT	x3
4 - TOP CROSSBAR - RIGHT	x1
5 - CROSSBAR - LEFT	x3
6 - TOP CROSSBAR - LEFT	x1
7 - BASE APRON	x2

HARDWARE REQUIRED

A		28
H		16

TOOLS REQUIRED

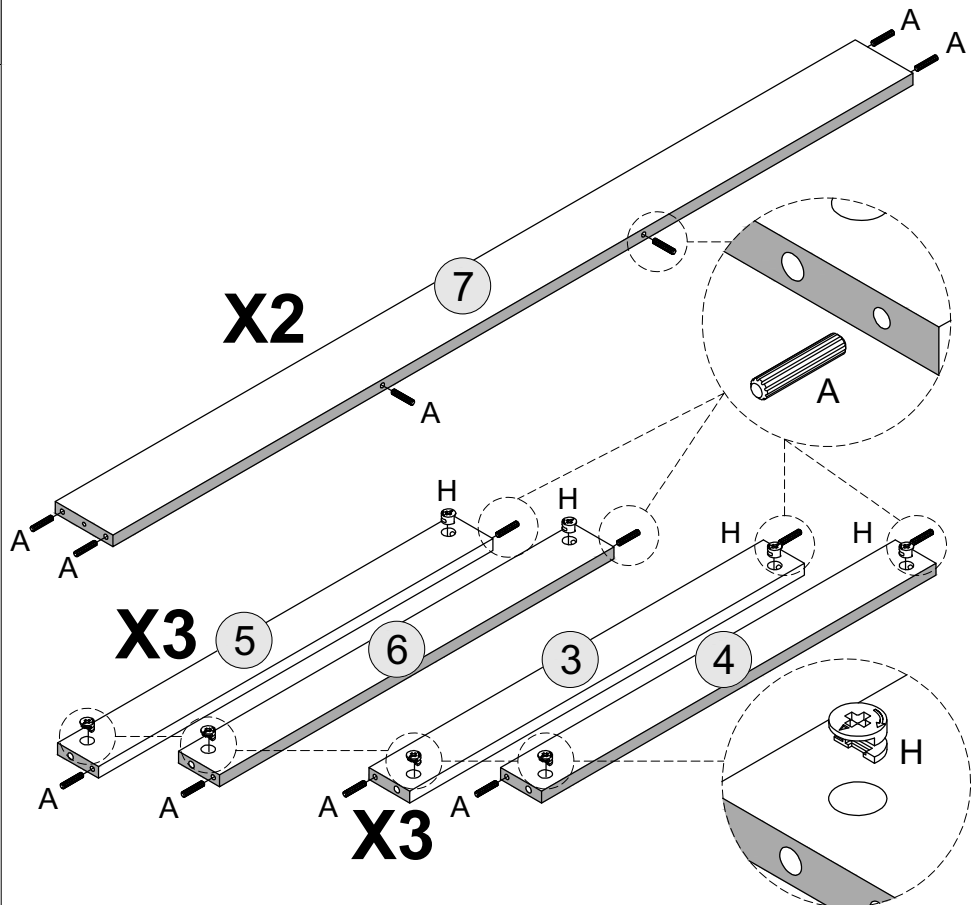
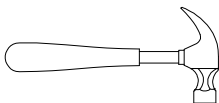

STEP 7

PARTS REQUIRED

- 1 - CENTRE PANEL x1
- 2 - BOTTOM PANEL x1

HARDWARE REQUIRED

- N  02

TOOLS REQUIRED

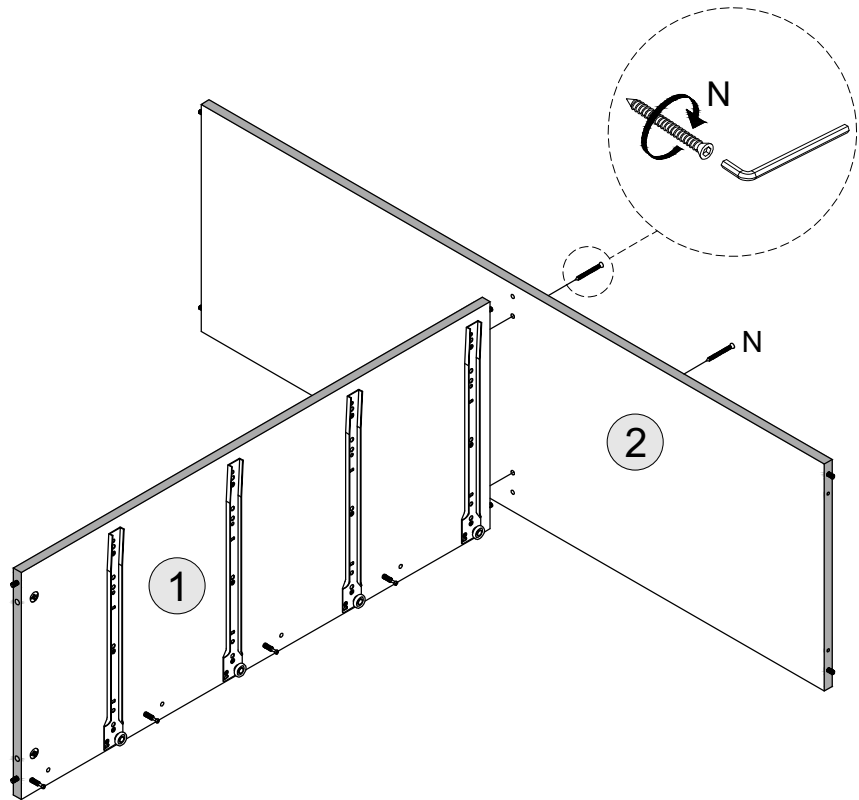

STEP 8

PARTS REQUIRED

- 3 - CROSSBAR - RIGHT x3
- 4 - TOP CROSSBAR - RIGHT x1

HARDWARE REQUIRED

TOOLS REQUIRED

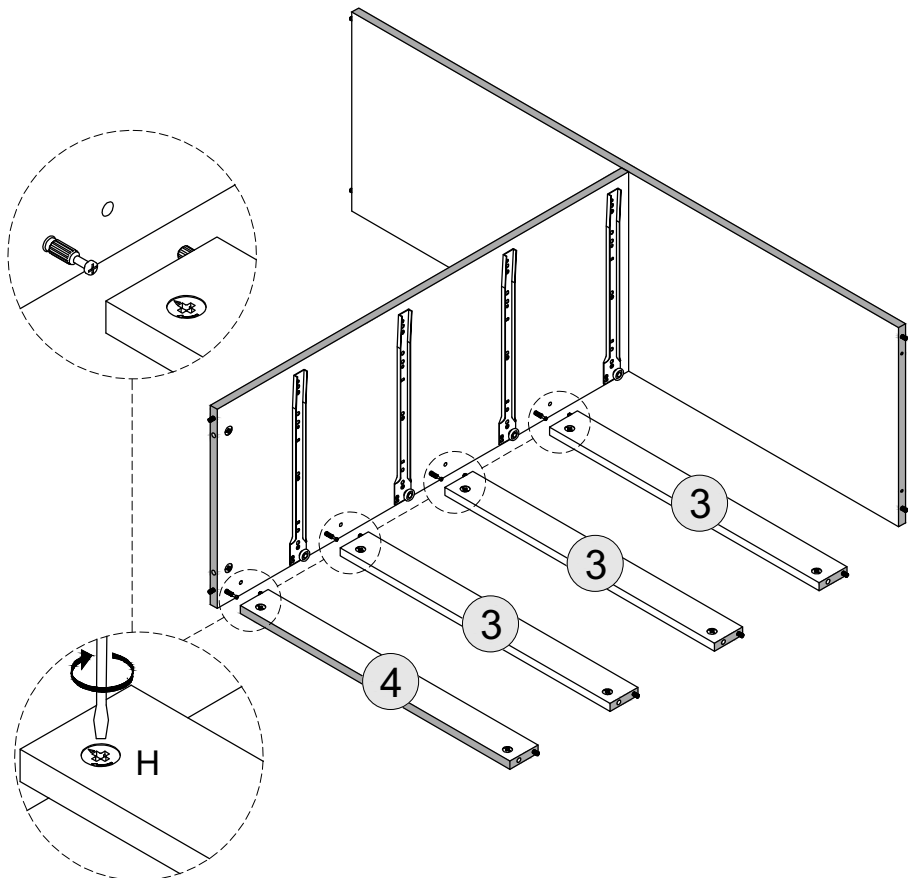
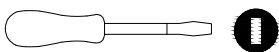

STEP 9

PARTS REQUIRED

5 - CROSSBAR - LEFT x3

6 - TOP CROSSBAR - LEFT x1

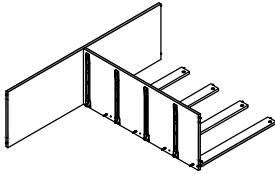

HARDWARE REQUIRED

TOOLS REQUIRED

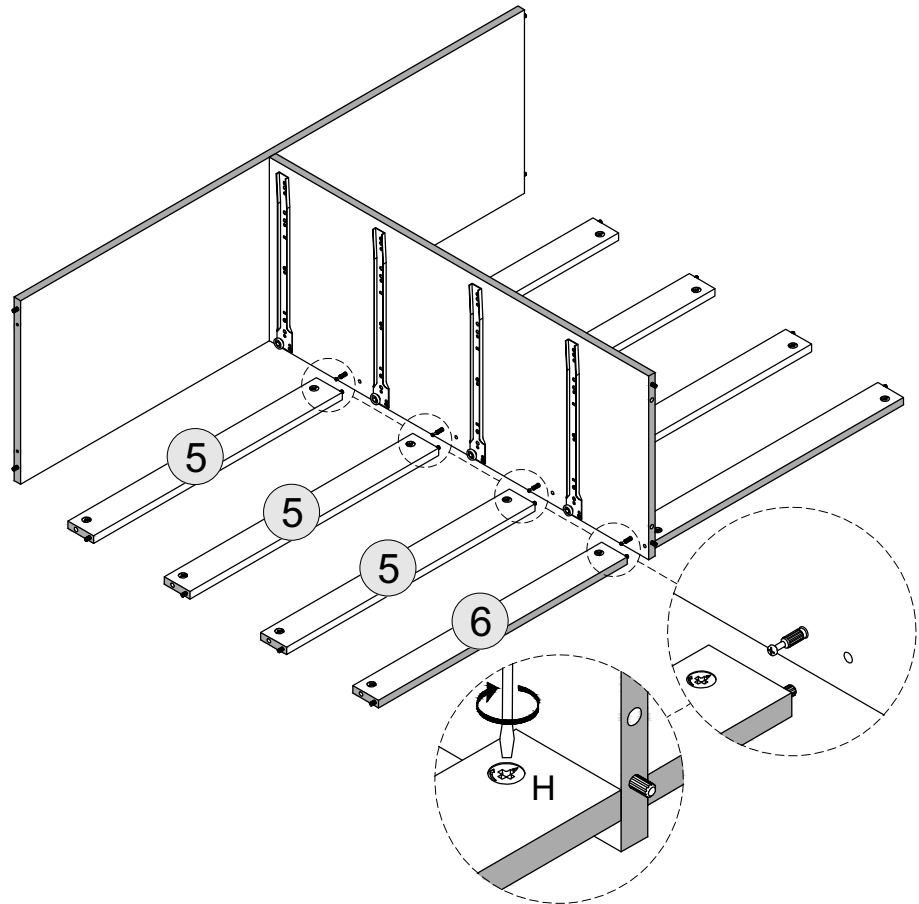
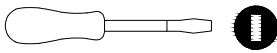

STEP 10

PARTS REQUIRED

7 - BASE APRON x2

8 - SIDE PANEL - RIGHT x1

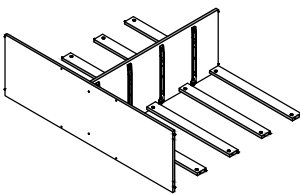

HARDWARE REQUIRED

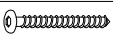
C  04

TOOLS REQUIRED

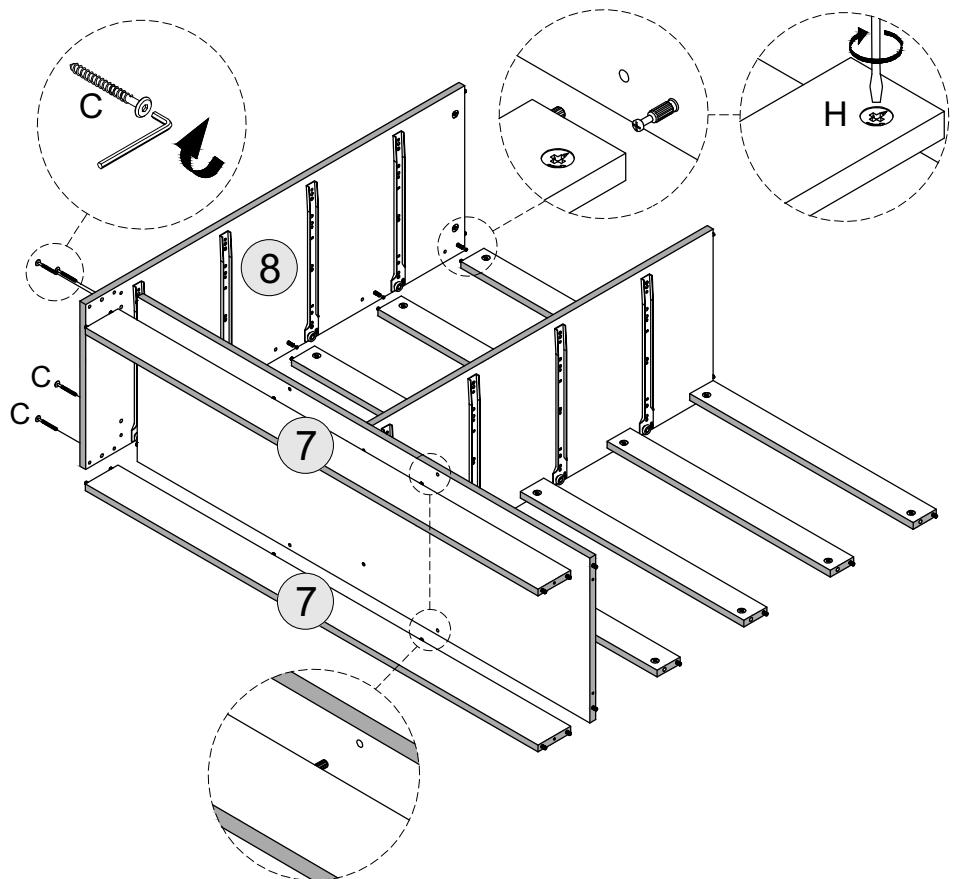
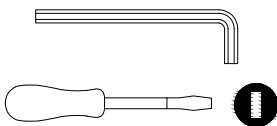

STEP 11

PARTS REQUIRED

9 - SIDE PANEL - LEFT x1

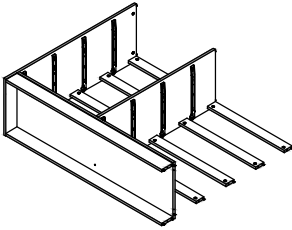

HARDWARE REQUIRED

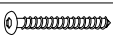
C  04

TOOLS REQUIRED

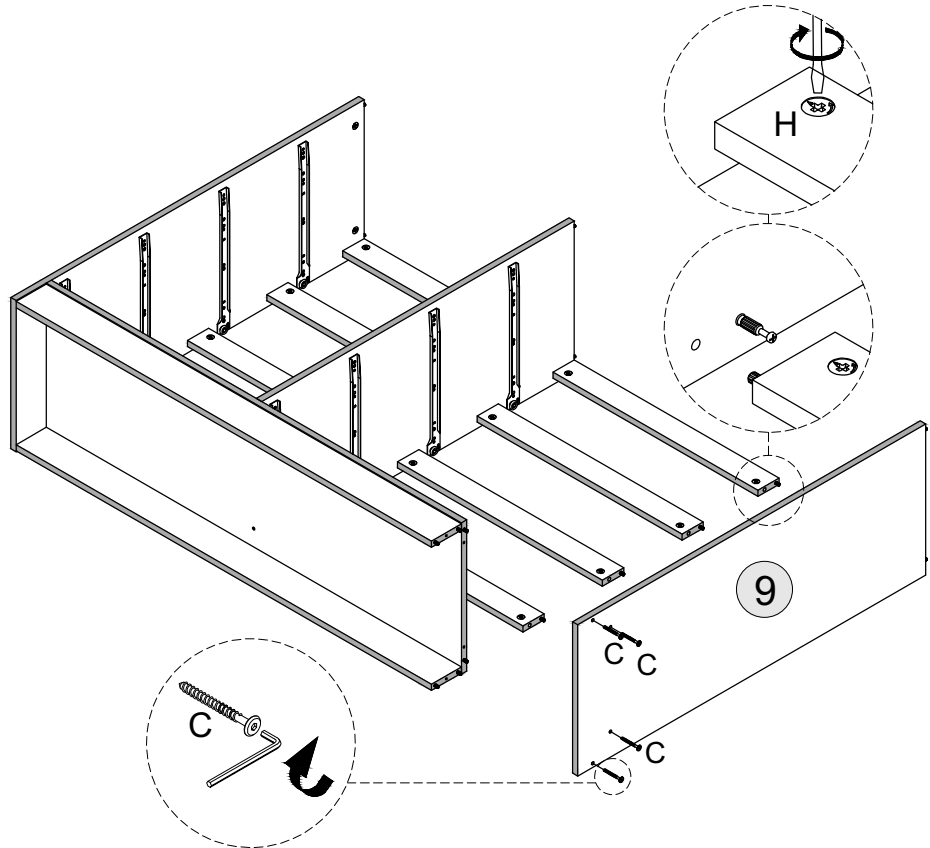
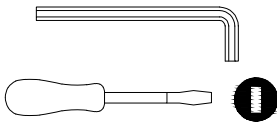

STEP 12

PARTS REQUIRED

10 - TOP PANEL x1

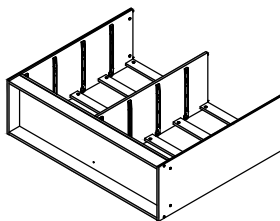

HARDWARE REQUIRED

D  06

F  06

TOOLS REQUIRED

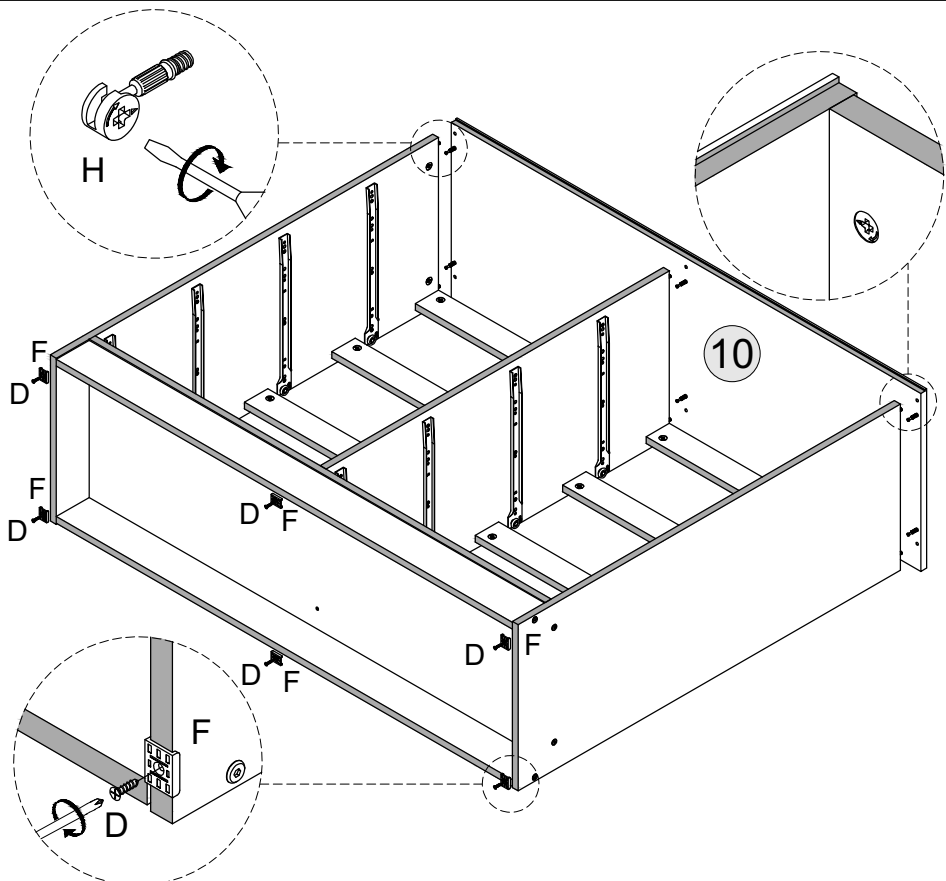
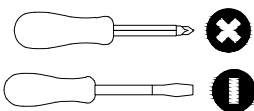

STEP 13

PARTS REQUIRED

11 - BACK PANEL	x2
12 - BACK PANEL - CENTRE	x1

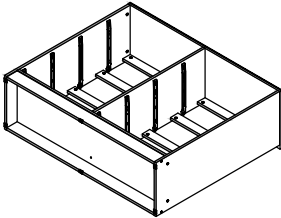

HARDWARE REQUIRED

E		40
L		02

TOOLS REQUIRED

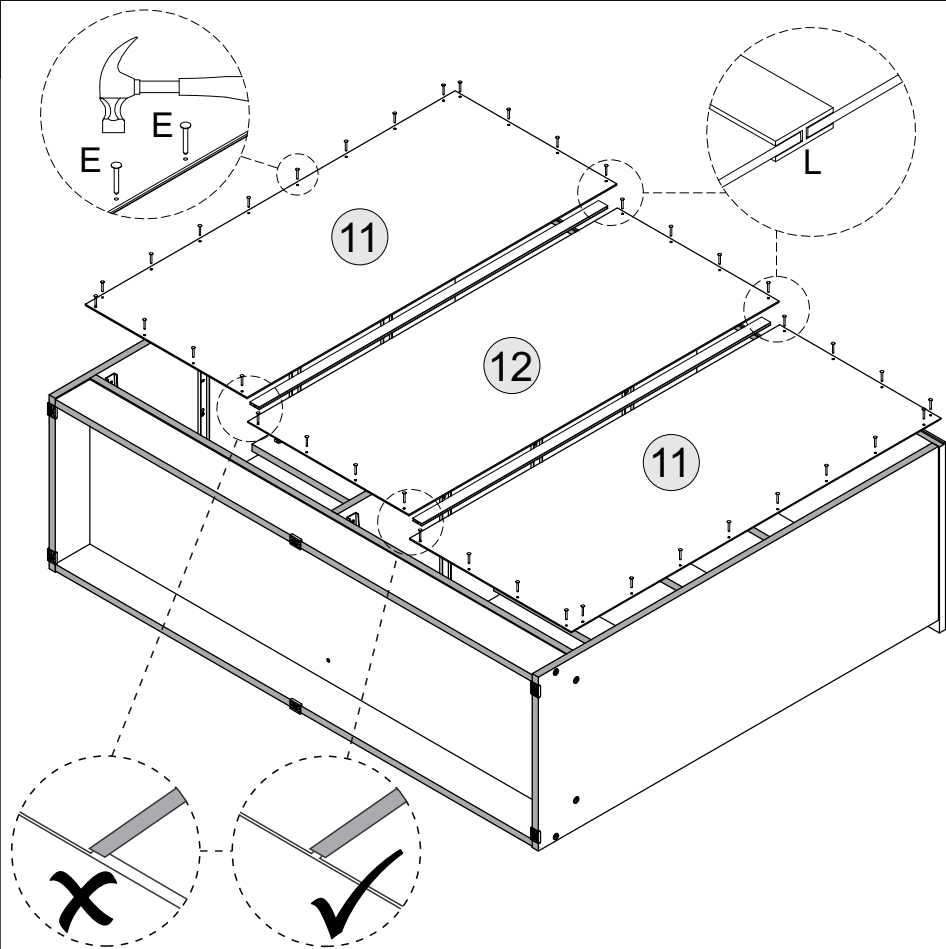
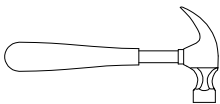

STEP 14

PARTS REQUIRED

13 - DRAWER BACK	x8
14 - DRAWER SIDE-LEFT	x8
15 - DRAWER SIDE-RIGHT	x8
16 - DRAWER FRONT - LEFT	x4
19 - DRAWER FRONT - RIGHT	x4

HARDWARE REQUIRED

A		64
H		24
H		16
K		16

TOOLS REQUIRED

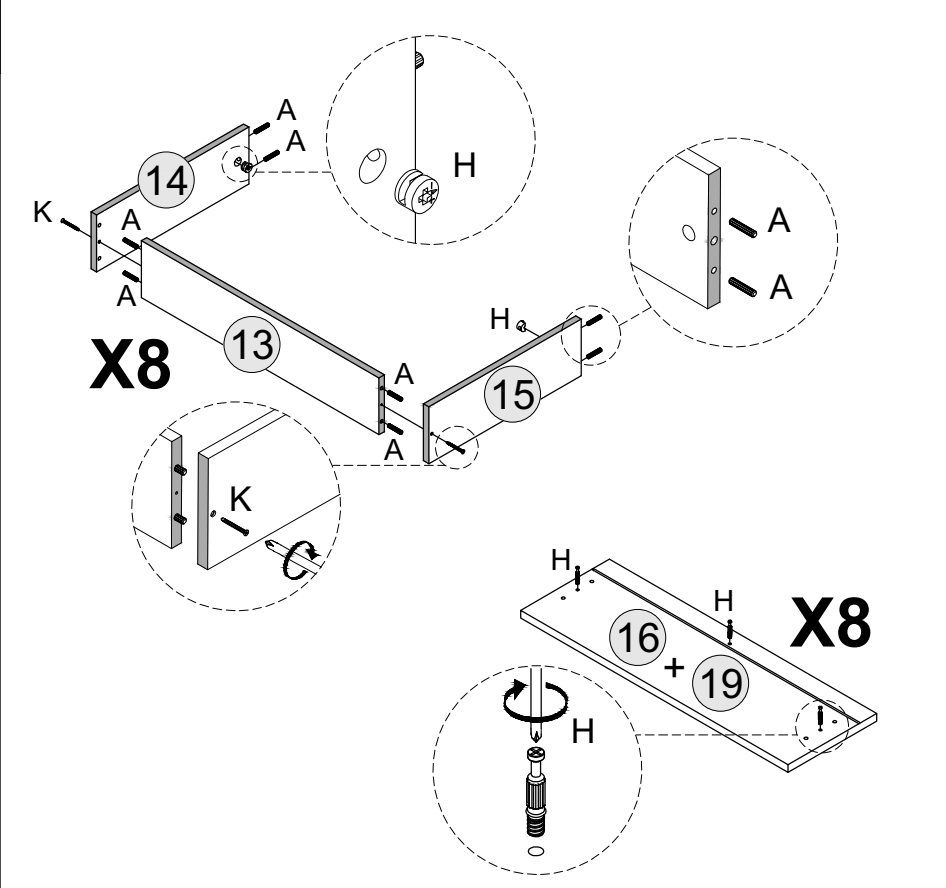
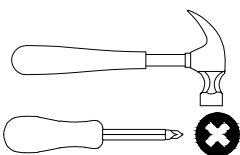

STEP 15

PARTS REQUIRED

17 - DRAWER BASE x8

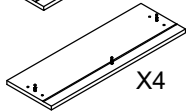
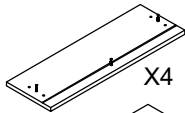
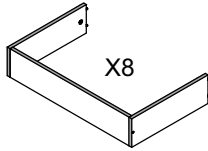

HARDWARE REQUIRED

G  48

TOOLS REQUIRED

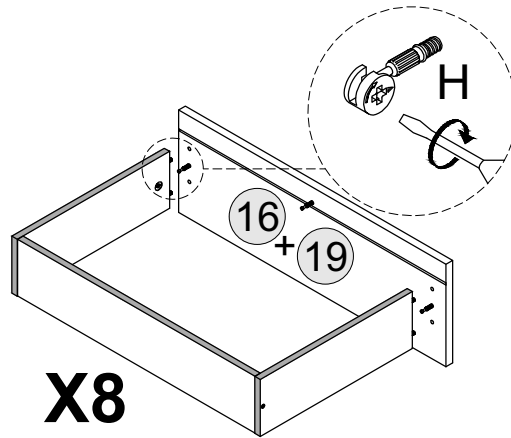
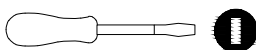
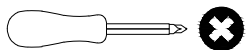

X8

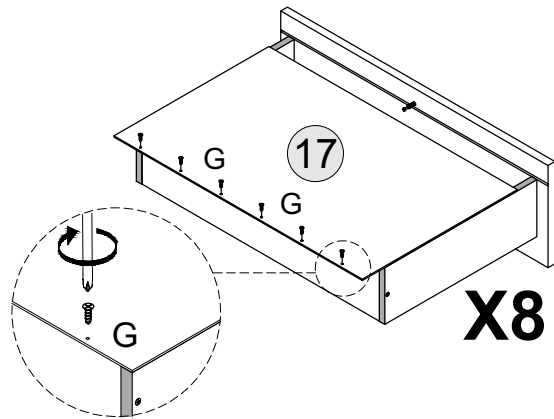

X8

STEP 16

PARTS REQUIRED

18 - DRAWER BOTTOM SUPPORT RAIL x8

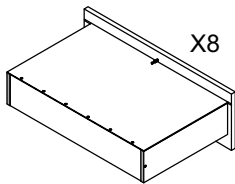

HARDWARE REQUIRED

D  48

H  08

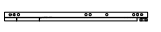
J  16

M  16

TOOLS REQUIRED

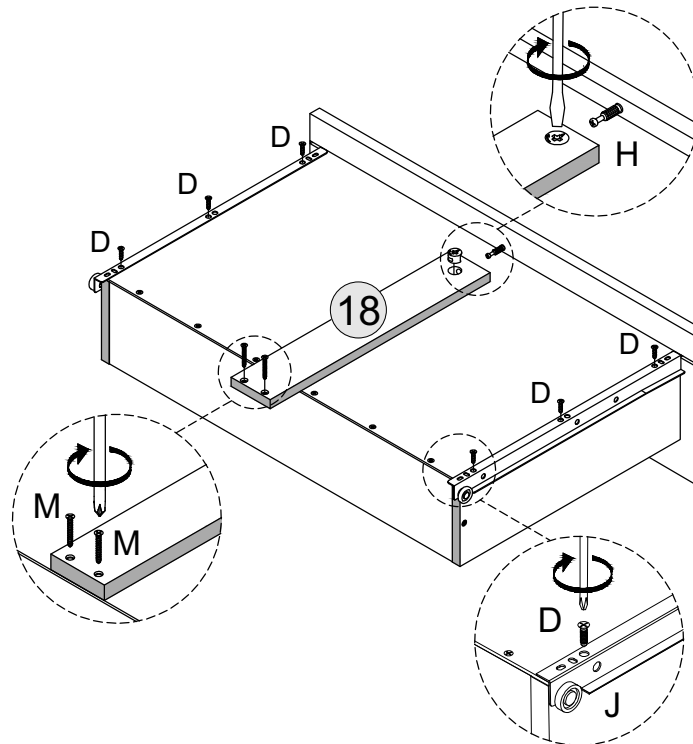
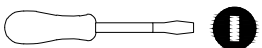
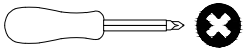

X8

STEP 17

PARTS REQUIRED

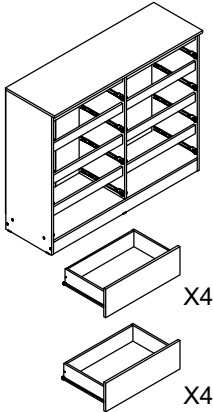

HARDWARE REQUIRED

TOOLS REQUIRED

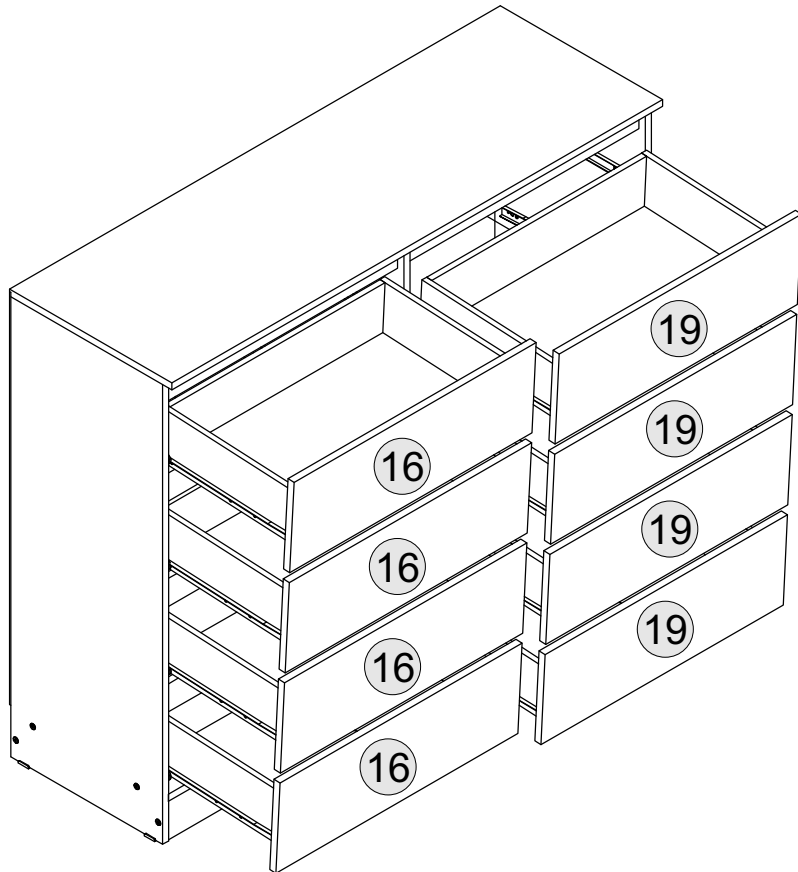

STEP 18

PARTS REQUIRED

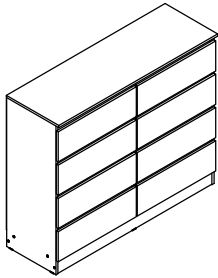

HARDWARE REQUIRED

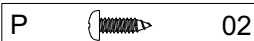

TOOLS REQUIRED

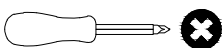

WARNING

Serious or fatal injuries can occur from furniture tipping over. To prevent the furniture from tipping over we recommend that it is permanently fixed to the wall.

Wall fixings are not supplied with this product as different wall materials require different types of fixing devices. Please make sure you use fixings suitable for the walls in your home.

