

BERGEN 2 DOOR 2 DRAWER SIDEBBOARD

OAK EFFECT/WHITE/GREY

ASSEMBLY INSTRUCTIONS

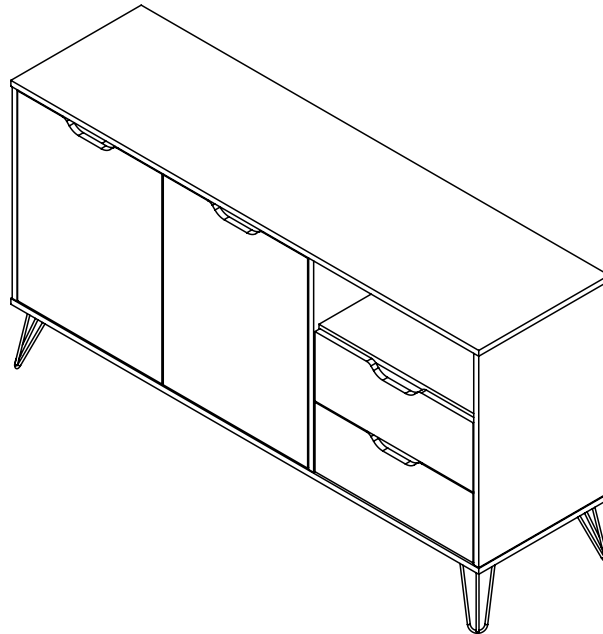

IMPORTANT FOR DOMESTIC USE ONLY

PLEASE READ BEFORE YOU CONTINUE FURTHER

CARE AND MAINTENANCE

After unpacking this product please keep the original packaging in case it needs to be returned for any reason.

- Please ensure all fittings and parts are present before commencing with assembly.
- Never drag or push products as this could cause damage to the joints making it inferior.
- We strongly recommend that you keep children away from your work area.
- We recommend that you lay a blanket or sheet on the floor to avoid damage to both your floor and the product.
- Assemble this product as close to its final position as possible.
- Do not place this product next to a radiator or in direct sunlight.
- Do not drag or push items across your high gloss furniture as this may cause the surface to scratch
- Wood is a natural product and may expand if subjected to damp and may shrink or crack if subjected to heat. Therefore it is recommended that room temperature is maintained, with no sudden temperature fluctuations.
- Make sure any spillage is wiped off immediately.
- Do not place hot or chilled items directly on to the surface, use a place mat or marking will occur.
- For general cleaning use a soft cotton or micro fibre cloth, and do not use detergents of any kind.
- From time to time it may be necessary to tighten fittings, regular inspections should be carried out.
- Do not place on a wet or damp floor as staining may occur to your floor.

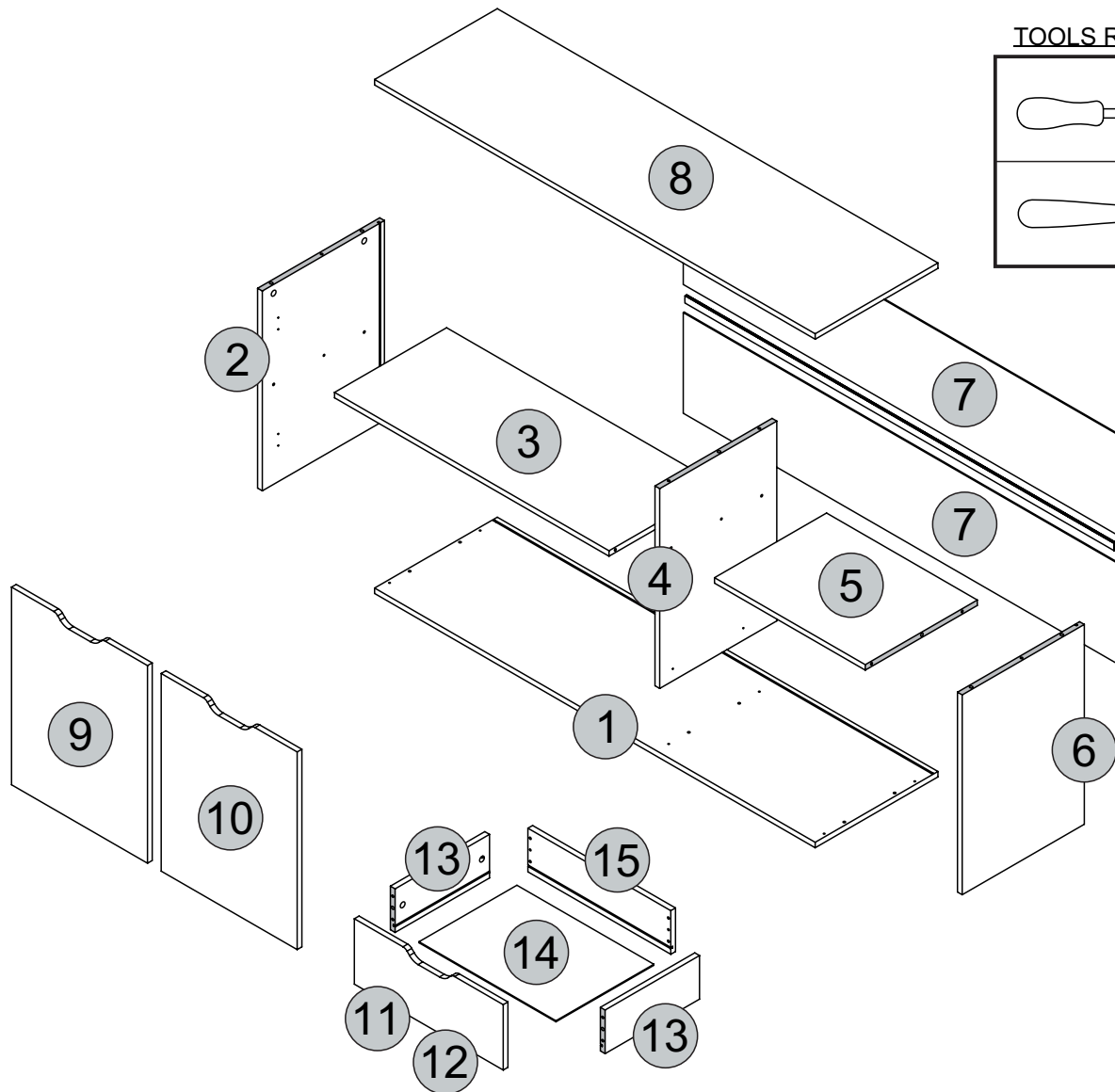

TOOLS REQUIRED

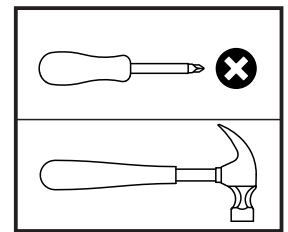











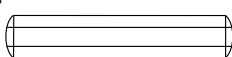
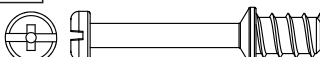
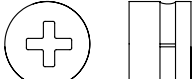
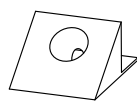
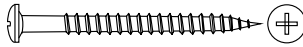

PARTS LIST

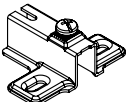
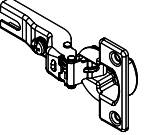
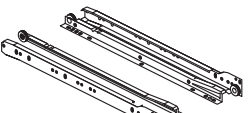
Please Note:

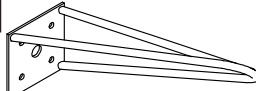
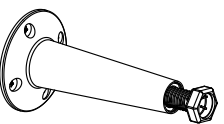
The below parts have all been stamped with the part number to help identify them during assembly.

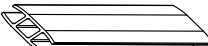
Part Number	Part Code	Part Description	Quantity	Carton
1	S400-405-032-AY1 - 01	Base Panel	1	2/2
2	S400-405-032-AY1 - 02	Left Side Panel	1	2/2
3	S400-405-032-AY1 - 03	Shelf Panel	1	2/2
4	S400-405-032-AY1 - 04	Division Panel	1	2/2
5	S400-405-032-AY1 - 05	Fixed Shelf	1	1/2
6	S400-405-032-AY1 - 06	Right Side Panel	1	2/2
7	S400-405-032-AY1 - 07	Back Panel	2	2/2
8	S400-405-032-AY1 - 08	Top Panel	1	2/2
9	S400-405-032-AY1 - 09	Left Door	1	1/2
10	S400-405-032-AY1 - 10	Right Door	1	1/2
11	S400-405-032-AY1 - 11	Lower Drawer Front	1	1/2
12	S400-405-032-AY1 - 12	Drawer Front	1	1/2
13	S400-405-032-AY1 - 13	Drawer Side	4	1/2
14	S400-405-032-AY1 - 14	Drawer Bottom	2	2/2
15	S400-405-032-AY1 - 15	Drawer Back Panel	2	1/2

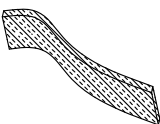
FITTINGS LIST

<p>A</p>  <p>2/+ Dowel Ø6,0 x 30mm (34x)</p>	<p>B</p>  <p>2/+ Cam Bolt (17x)</p>	<p>C</p>  <p>2/+ Cam Nut (17x)</p>	<p>D</p>  <p>2/+ Plastic Corner (16x)</p>
<p>E</p>  <p>1/+ Pan Head Screw Ø3,5 x 40mm (6x)</p>	<p>F</p>  <p>2/+ Pan Head Screw Ø3 x 16mm (16x)</p>	<p>G</p>  <p>2/+ Pan Head Screw Ø3,5 x 12mm (20x)</p>	<p>H</p>  <p>2/+ Pan Head Screw Ø4 x 14mm (36x)</p>
<p>I</p>  <p>Hinge Plate (4x)</p>	<p>J</p>  <p>Hinge (4x)</p>	<p>K</p>  <p>Drawer Runners (2x)</p>	<p>L</p>  <p>3/+ Hole Plugs (13x)</p>
<p>M</p>  <p>Metal Leg (4x)</p>	<p>N</p>  <p>Adjustable Leg (1x)</p>	<p>O</p>  <p>Glue (2x)</p>	<p>P</p>  <p>Back Panel Strip (1x)</p>
<p>Q</p>  <p>Washer (4x)</p>	<p>R</p>  <p>Strap (2x)</p>	<p>S</p>  <p>Pan Head Screw Ø4 x 20mm (1x)</p>	

TIPS FOR FITTINGS CAM-LOCKS

WHEN FITTING CAM NUT, ENSURE STARTING POSITION IS CORRECT BEFORE YOU INSERT CONNECTING CAM BOLT. TURN CLOCKWISE UNTIL SECURE



↑
CORRECT



WRONG



WRONG



X

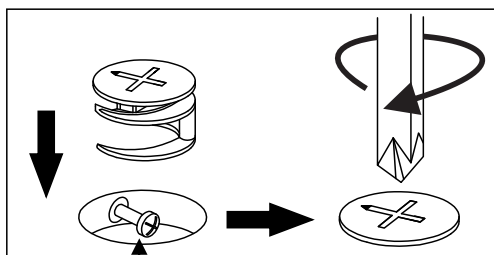

Cam bolt head needs to be in centre

CAMBOLT

Tighten until shoulder is flush with panel. Do not overtighten or undertighten (see example below)

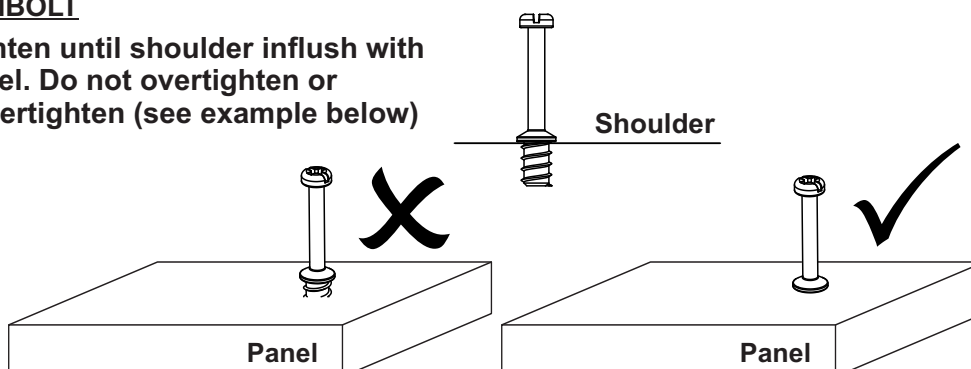

STEP 1

PARTS REQUIRED

8 - TOP PANEL x1

HARDWARE REQUIRED

B  05

TOOLS REQUIRED

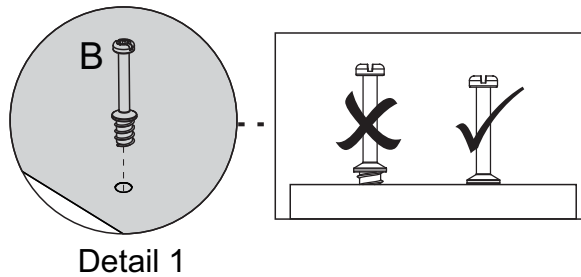
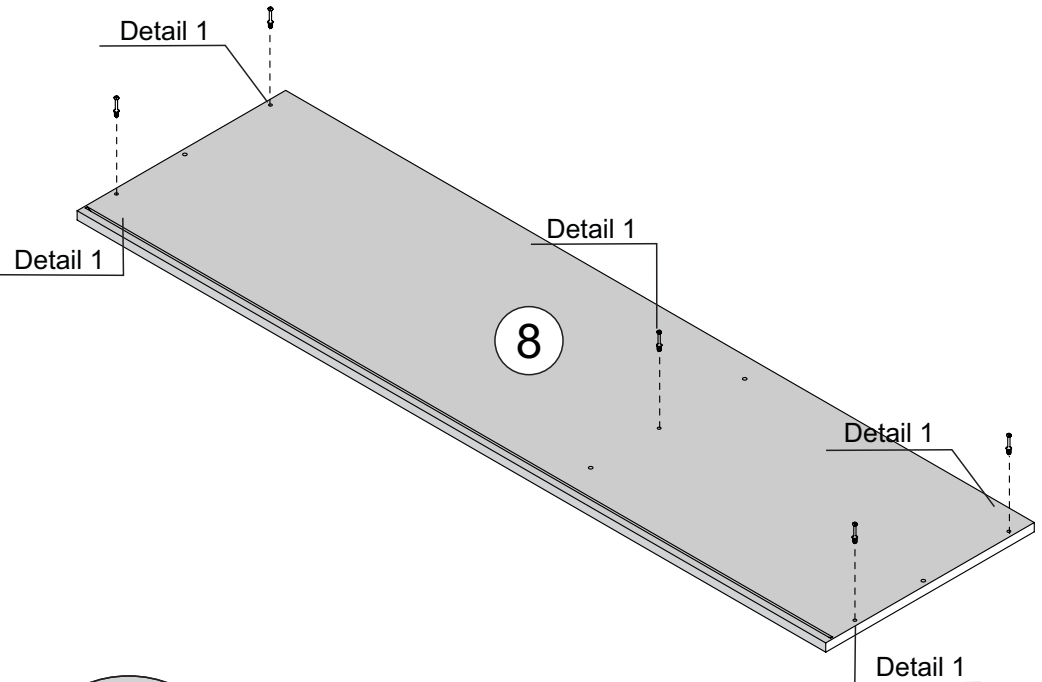
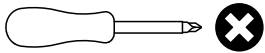

STEP 2

PARTS REQUIRED

3- SHELF PANEL x1

HARDWARE REQUIRED

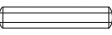
A  04

O  GLUE 01

TOOLS REQUIRED

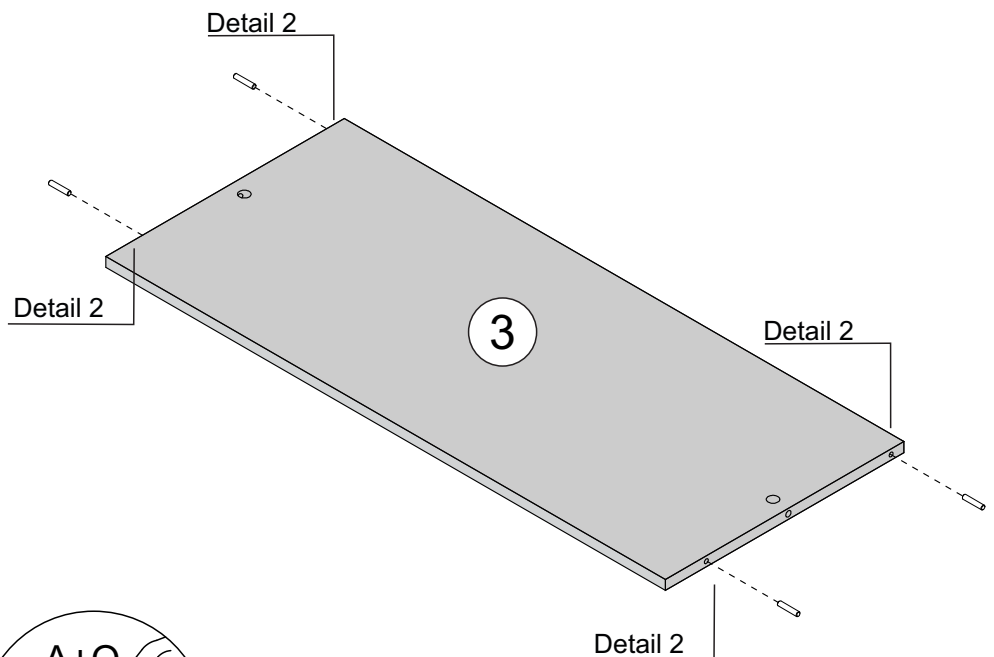
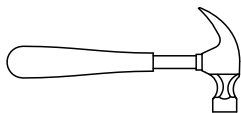

STEP 3

PARTS REQUIRED

5 - FIXED SHELF x1

HARDWARE REQUIRED

A  04

O  01

TOOLS REQUIRED

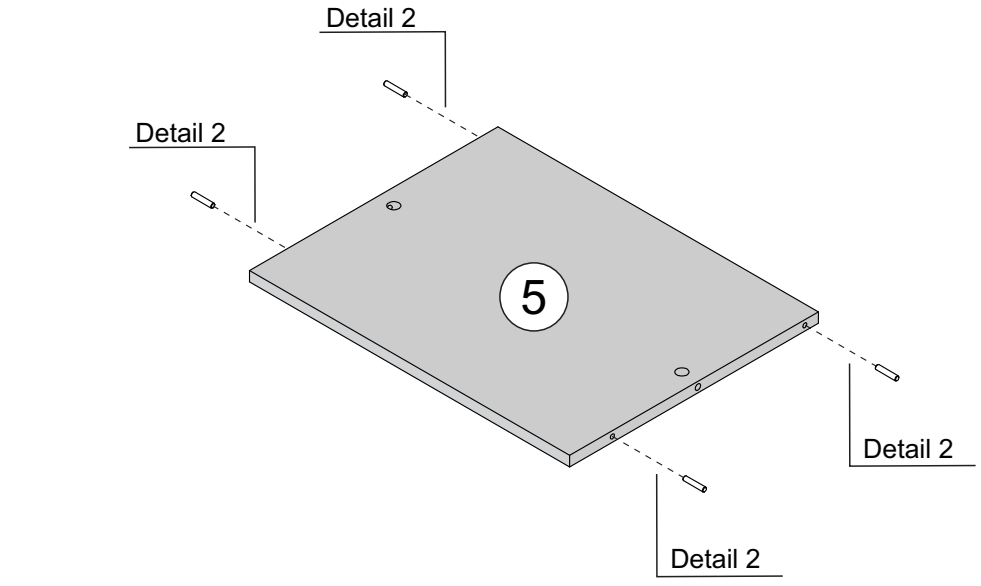
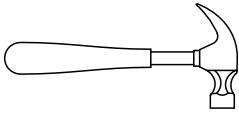

Detail 2

STEP 4

PARTS REQUIRED

2 - LEFT SIDE PANEL x1

HARDWARE REQUIRED

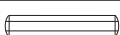
A  03

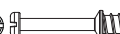
B  01

H  04

I  02

O  01

TOOLS REQUIRED

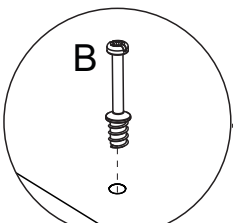
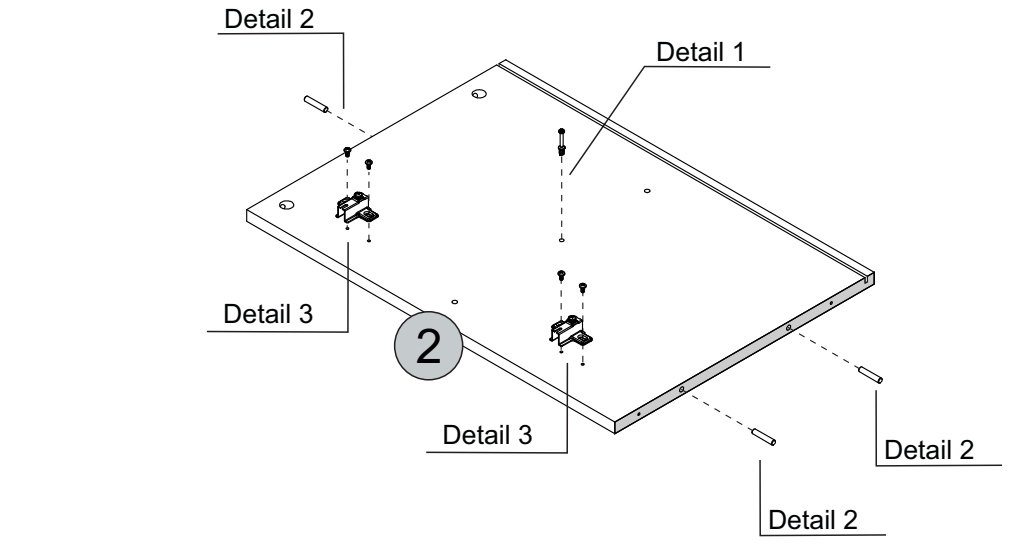
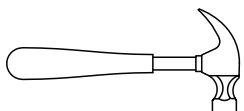
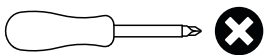

Detail 1

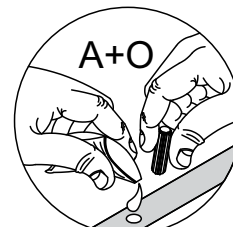
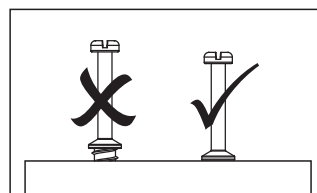

Detail 2

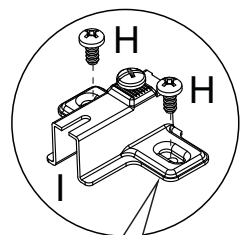

Please note:
Pre-marked
Holes





Detail 3

STEP 5

PARTS REQUIRED

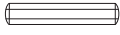
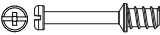
6 - RIGHT SIDE PANEL x1

HARDWARE REQUIRED

- A  03
- B  01
- G  06
- K  02
- O  01

TOOLS REQUIRED

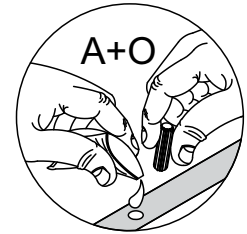
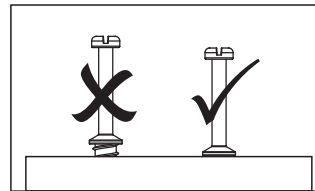
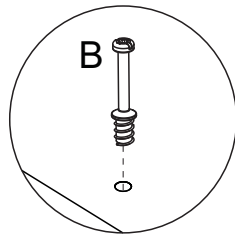
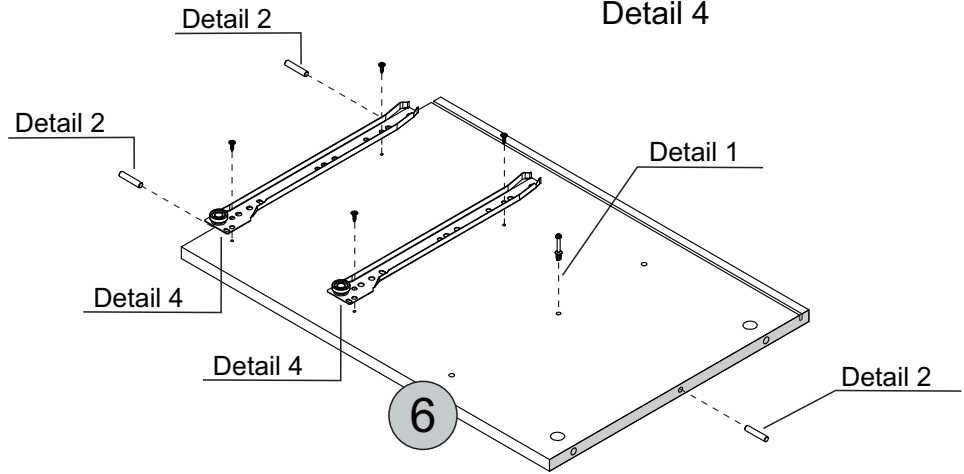
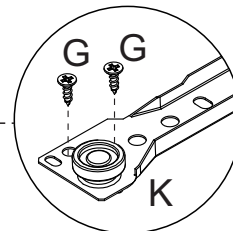
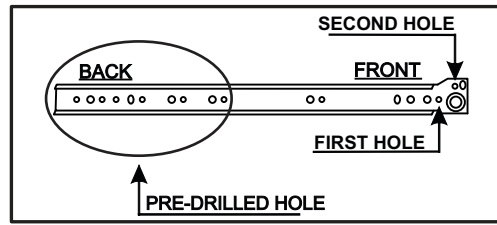
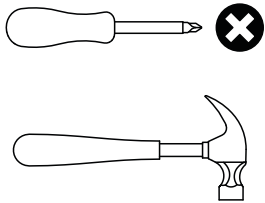

Detail 1





Detail 2

STEP 6

PARTS REQUIRED

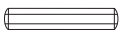
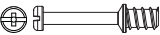
4 - DIVISION PANEL x1

HARDWARE REQUIRED

- A  04
- B  01
- H  04
- I  02
- O  01

TOOLS REQUIRED

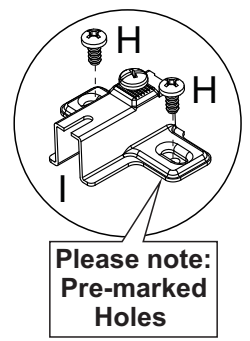
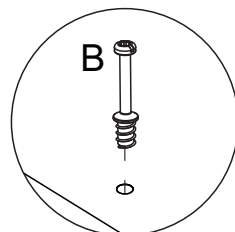
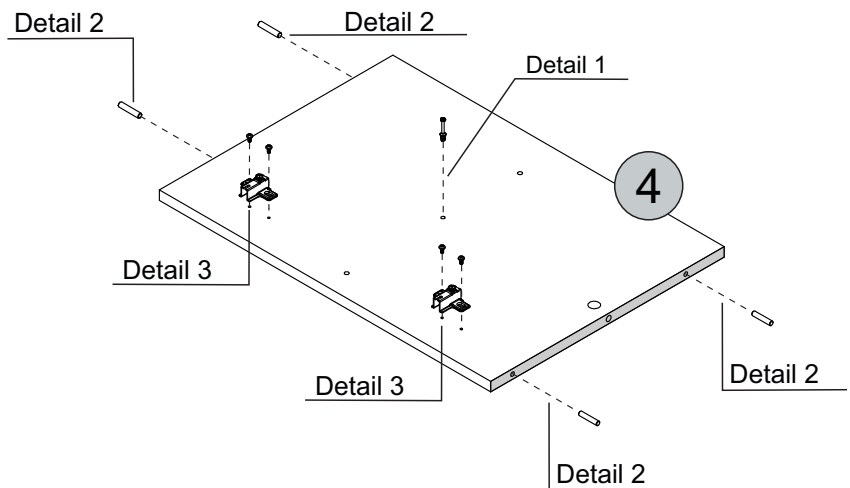
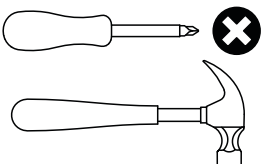

Please note:
Pre-marked
Holes

Detail 1

Detail 2

Detail 3

STEP 7

PARTS REQUIRED

4 - DIVISION PANEL x1

HARDWARE REQUIRED

G  06

K  02

TOOLS REQUIRED

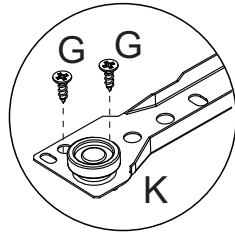
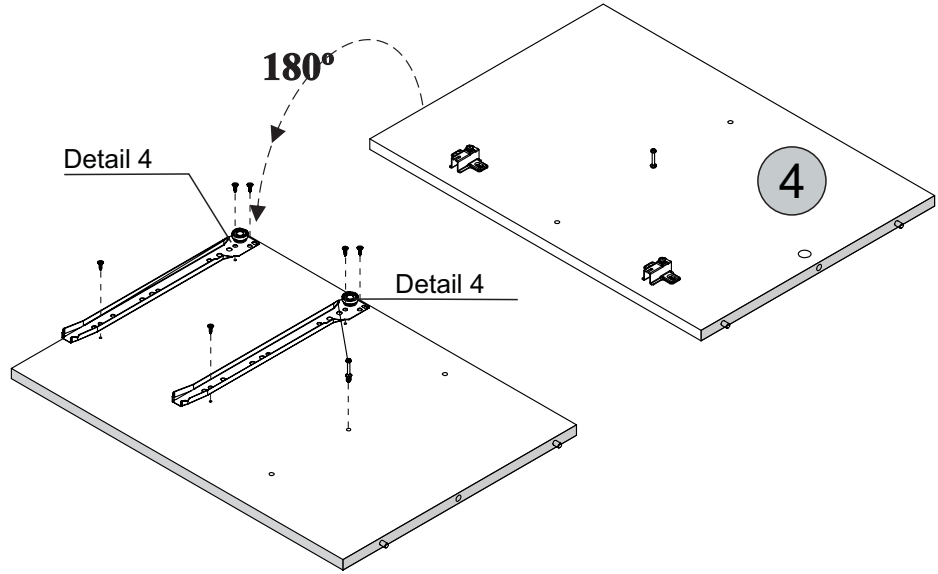
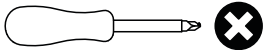

Detail 4

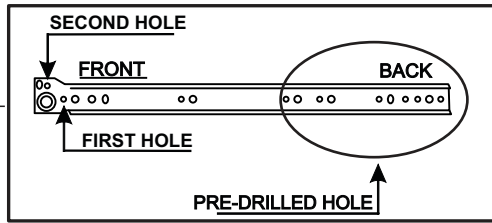

STEP 8

PARTS REQUIRED

2 - LEFT SIDE PANEL x1

3 - SHELF PANEL x1

HARDWARE REQUIRED

C  01

O  01

TOOLS REQUIRED

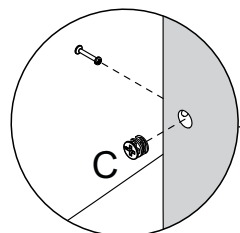
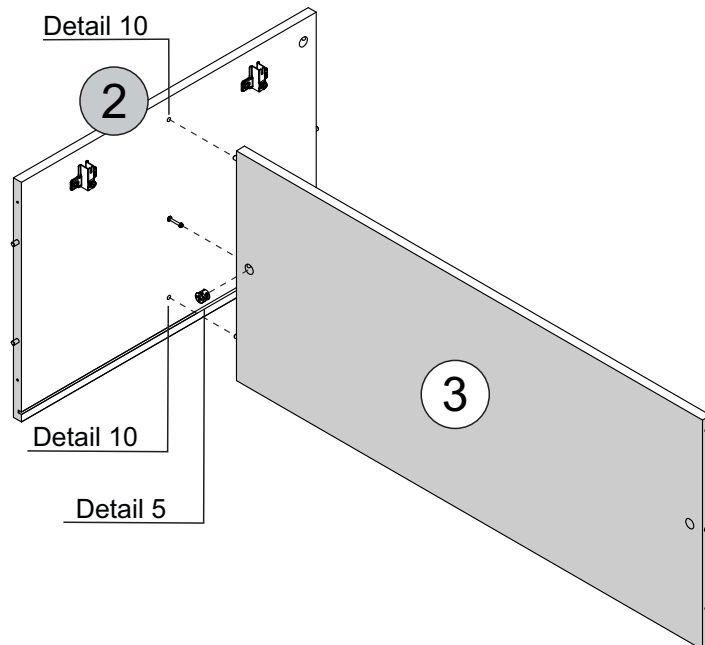
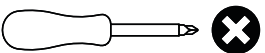

Detail 5

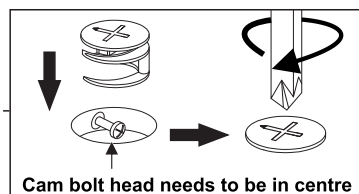

Cam bolt head needs to be in centre



Detail 10



STEP 9

PARTS REQUIRED

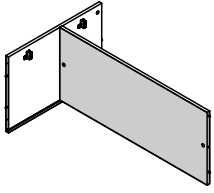
4 - DIVISION PANEL x1



HARDWARE REQUIRED

C   01

O  01

TOOLS REQUIRED

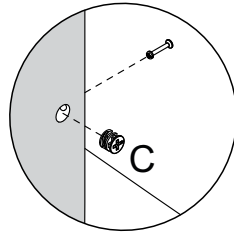
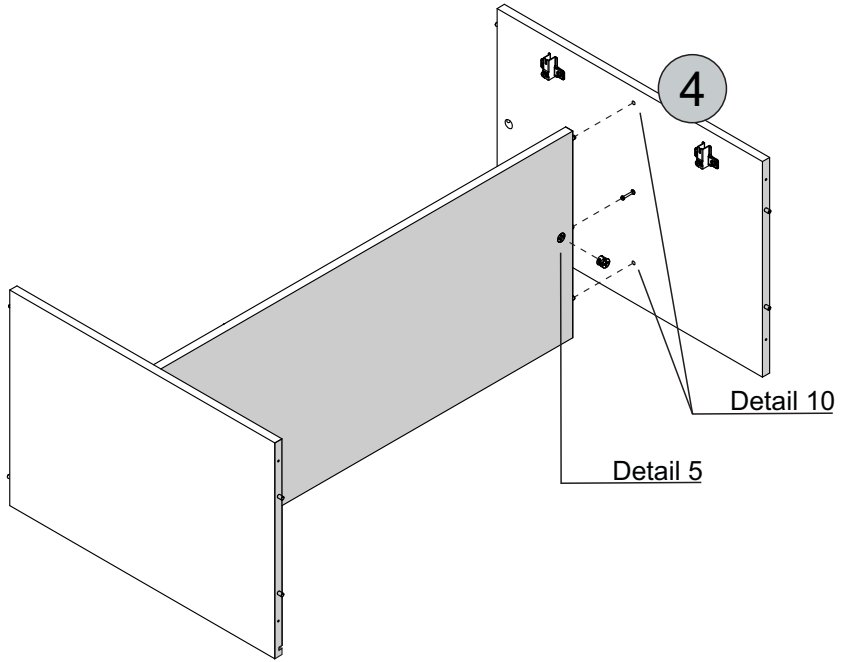
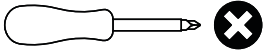

Detail 5

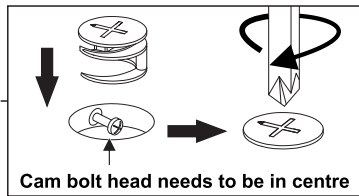

Detail 10



STEP 10

PARTS REQUIRED

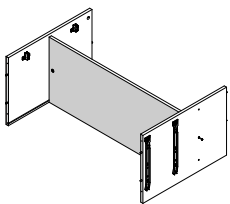
5 - FIXED SHELF x1



HARDWARE REQUIRED

C   01

O  01

TOOLS REQUIRED

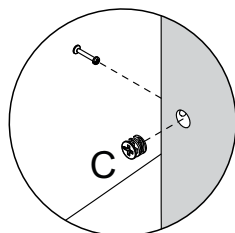
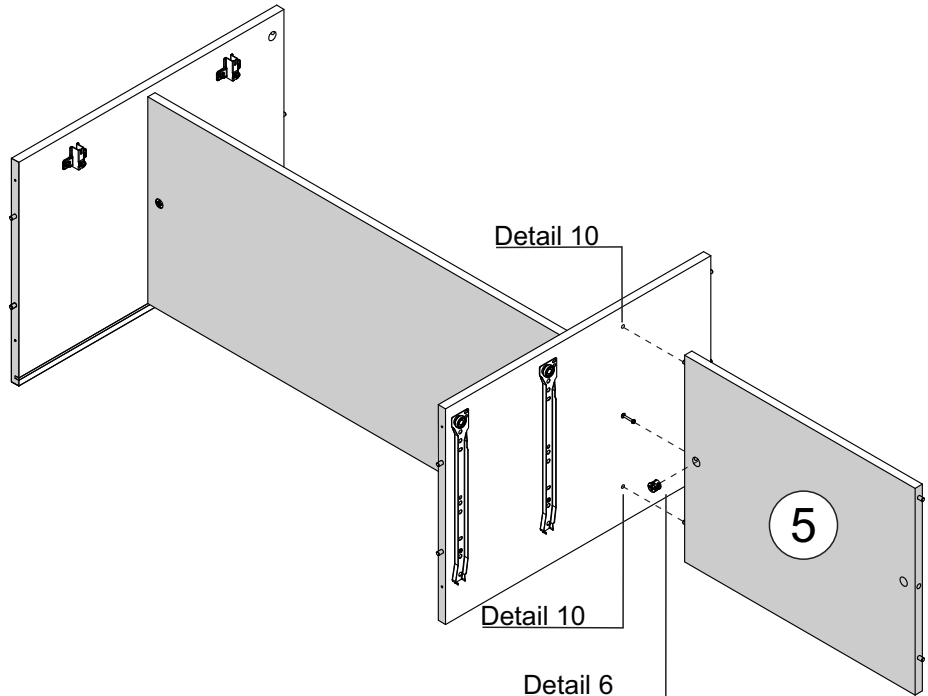
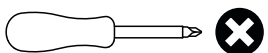

Detail 5

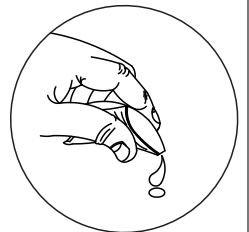
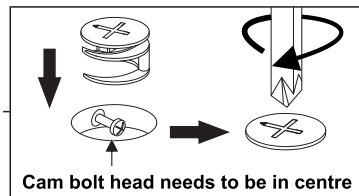

Detail 10

STEP 11

6 - RIGHT SIDE PANEL x1

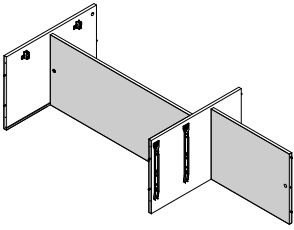

HARDWARE REQUIRED

C   01

O  GLUE 01

TOOLS REQUIRED

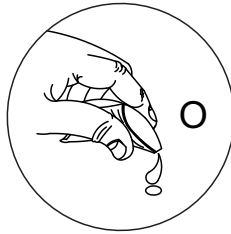
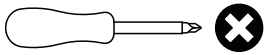

Detail 10

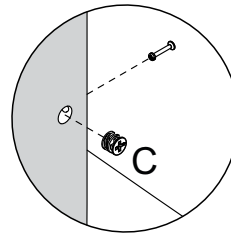
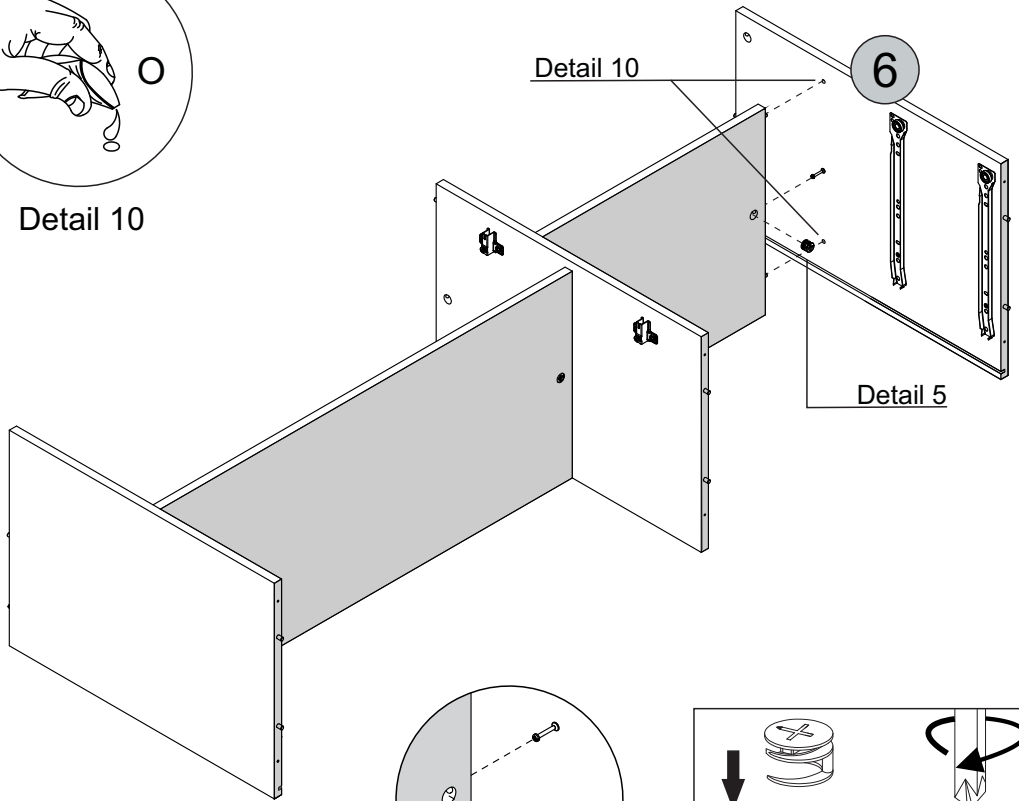

Detail 5

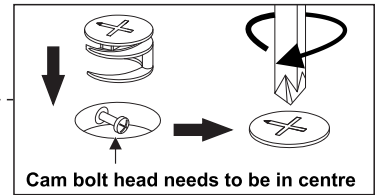

STEP 12

PARTS REQUIRED

1 - BASE PANEL x1

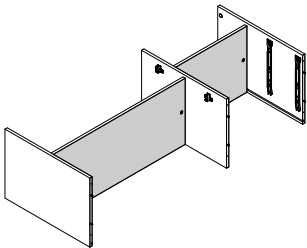

HARDWARE REQUIRED

E  06

O  GLUE 01

TOOLS REQUIRED

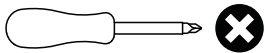

Detail 10

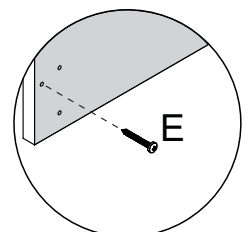
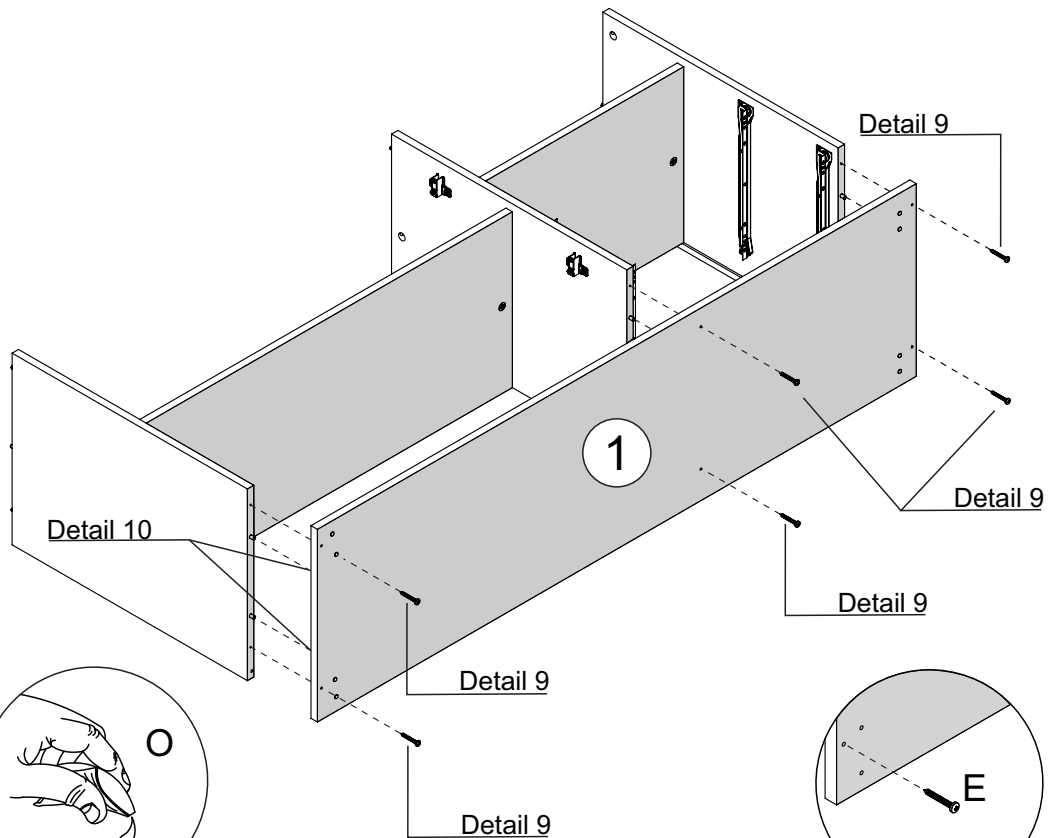

Detail 9

STEP 13

PARTS REQUIRED

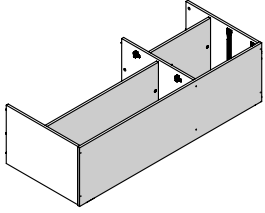

HARDWARE REQUIRED

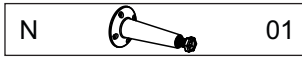
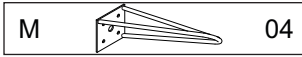

TOOLS REQUIRED

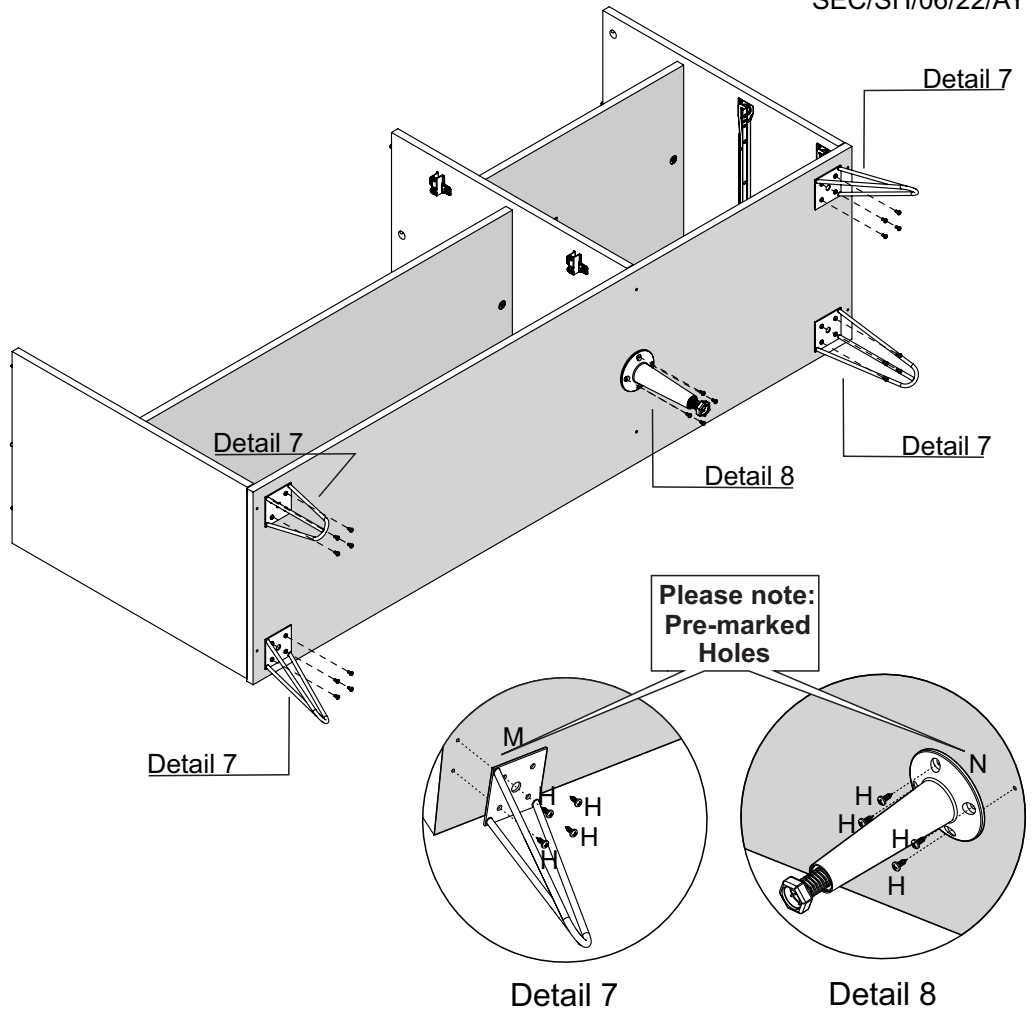
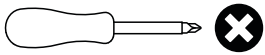

STEP 14

PARTS REQUIRED

7 - BACK PANEL x2

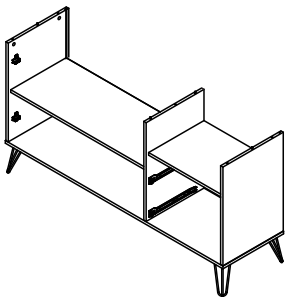

HARDWARE REQUIRED

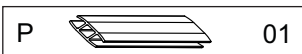

TOOLS REQUIRED

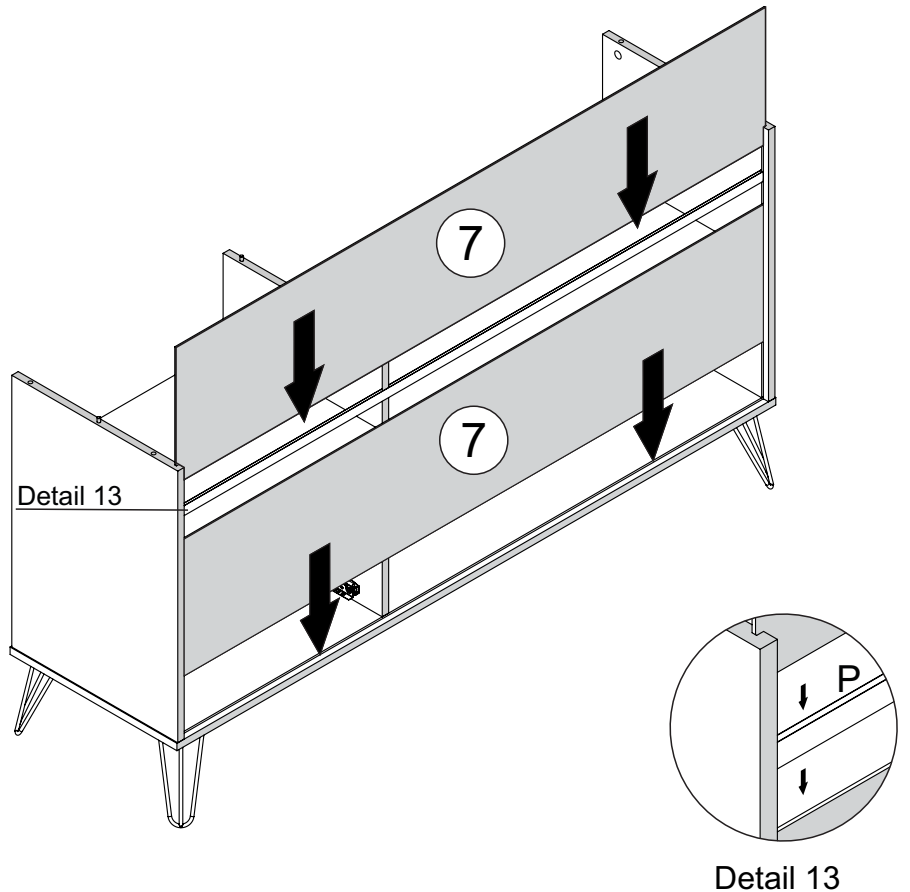

STEP 15

PARTS REQUIRED

8 - TOP PANEL x1

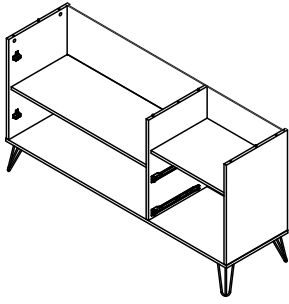

HARDWARE REQUIRED

C 05

L 05

O 01

TOOLS REQUIRED

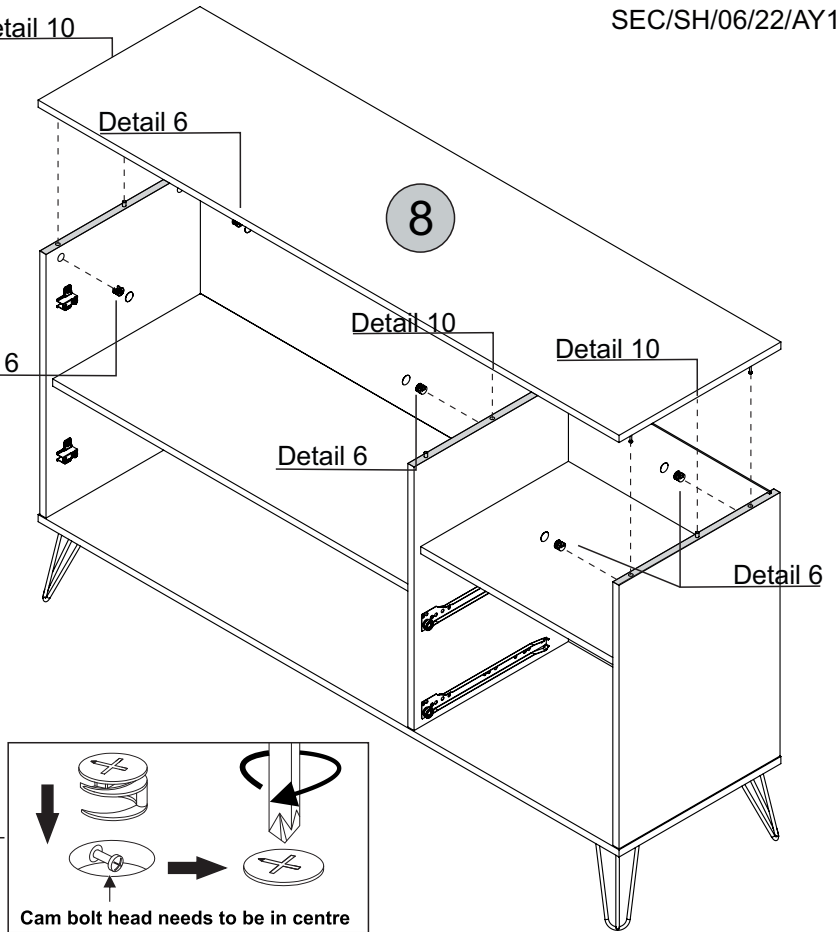
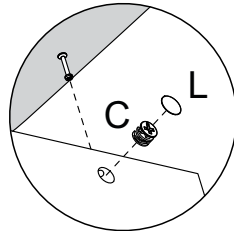
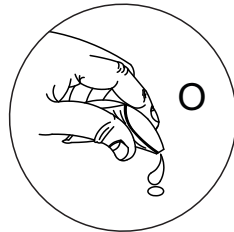
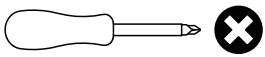

STEP 16

PARTS REQUIRED

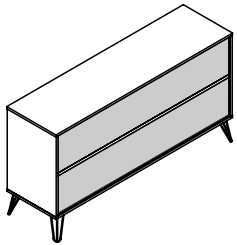

HARDWARE REQUIRED

D 16

F 16

TOOLS REQUIRED

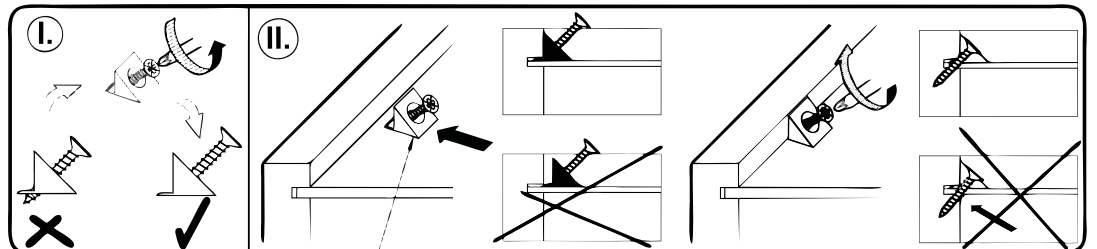
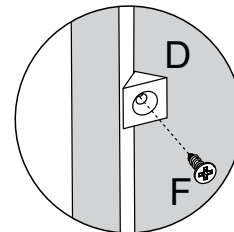
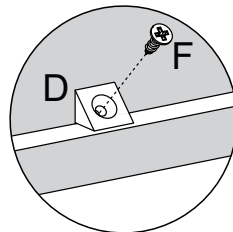
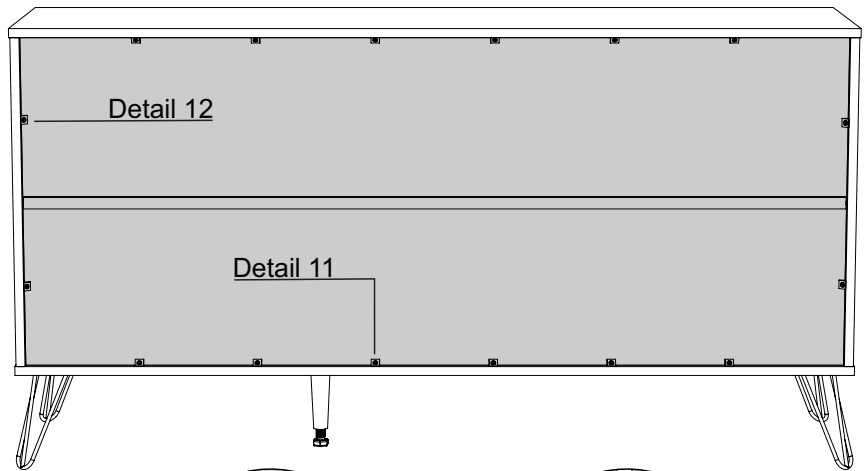
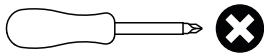

STEP 17

PARTS REQUIRED

9 - LEFT DOOR x1

10 - RIGHT DOOR x1

HARDWARE REQUIRED

H  08

J  04

TOOLS REQUIRED

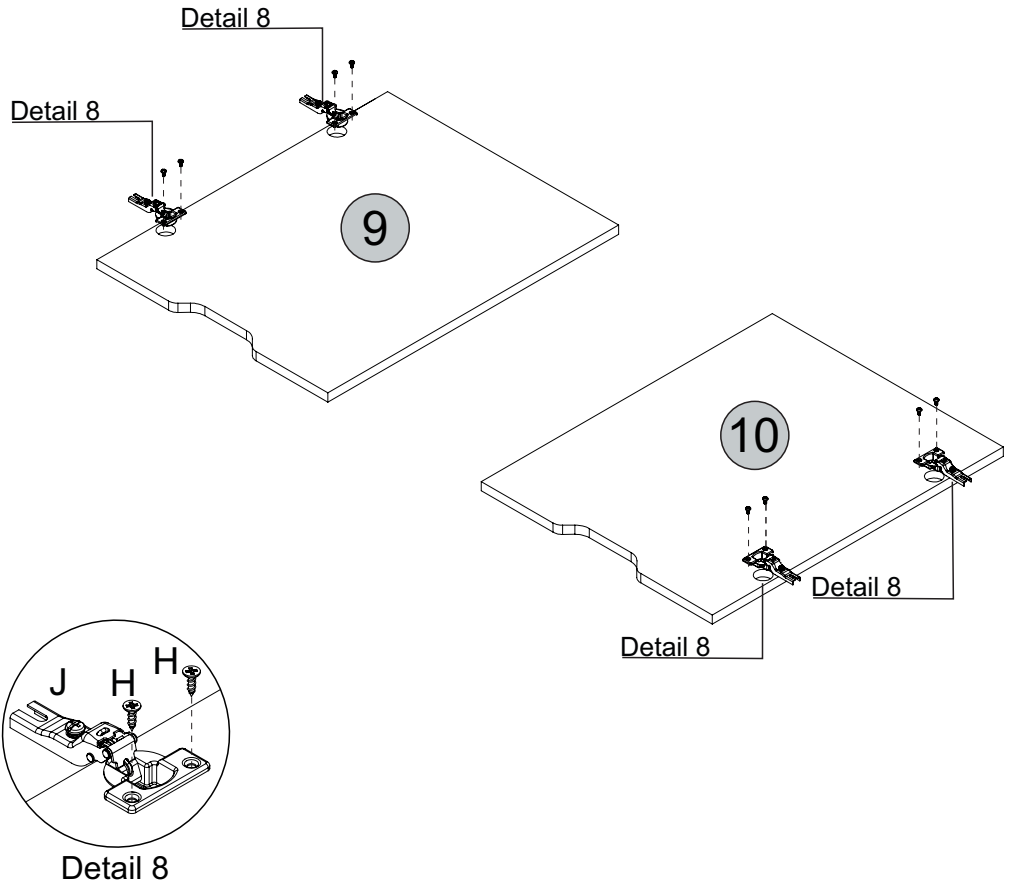
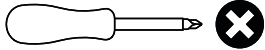

STEP 18

PARTS REQUIRED

9 - LEFT DOOR x1

10 - RIGHT DOOR x1

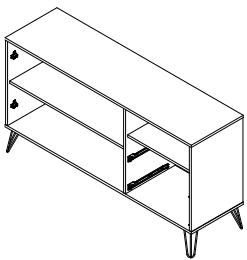

HARDWARE REQUIRED

TOOLS REQUIRED

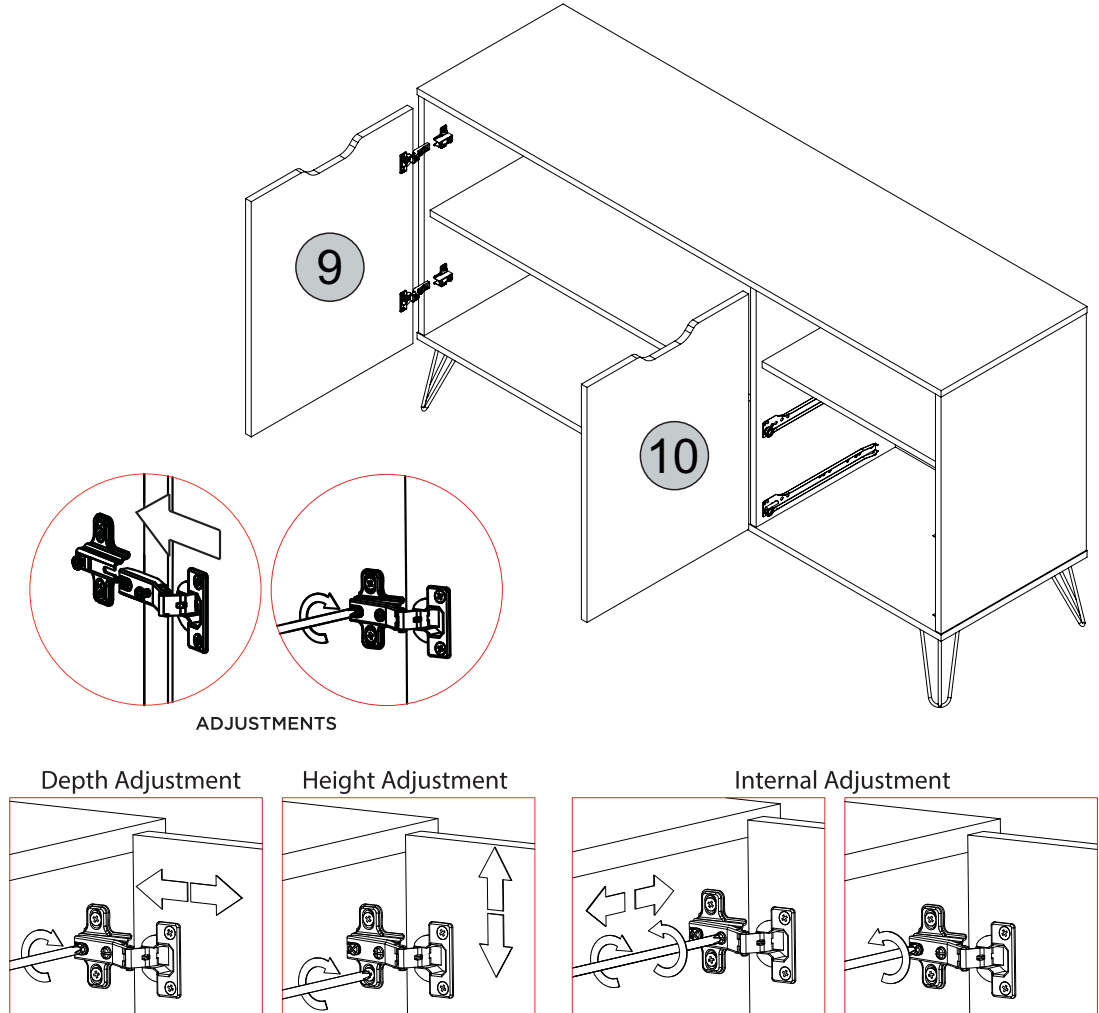



STEP 19

PARTS REQUIRED

- 11 - LOWER DRAWER FRONT x1
- 12 - DRAWER FRONT x1
- 13 - DRAWER SIDE x4
- 15 - DRAWER BACK x2

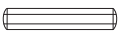
HARDWARE REQUIRED

- A  16
- B  08
- O  01

TOOLS REQUIRED

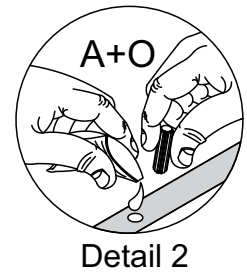
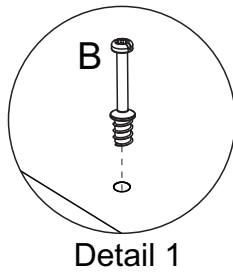
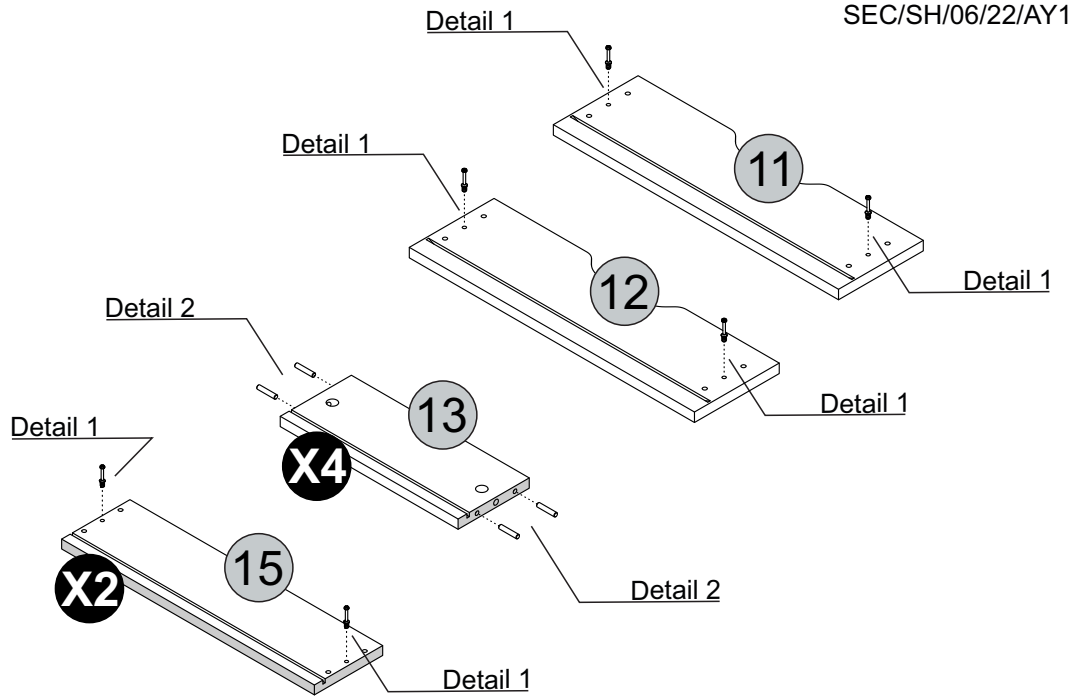
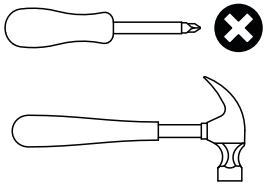



STEP 20

PARTS REQUIRED

- 13 - DRAWER SIDE x4
- 14 - DRAWER BOTTOM x2
- 15 - DRAWER BACK x2

HARDWARE REQUIRED

- C   04
- L  04

TOOLS REQUIRED

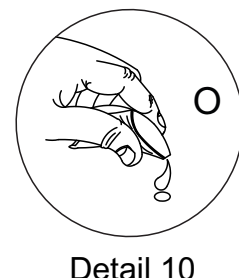
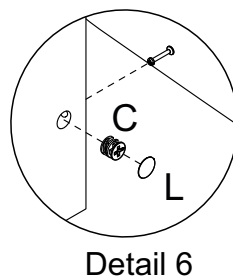
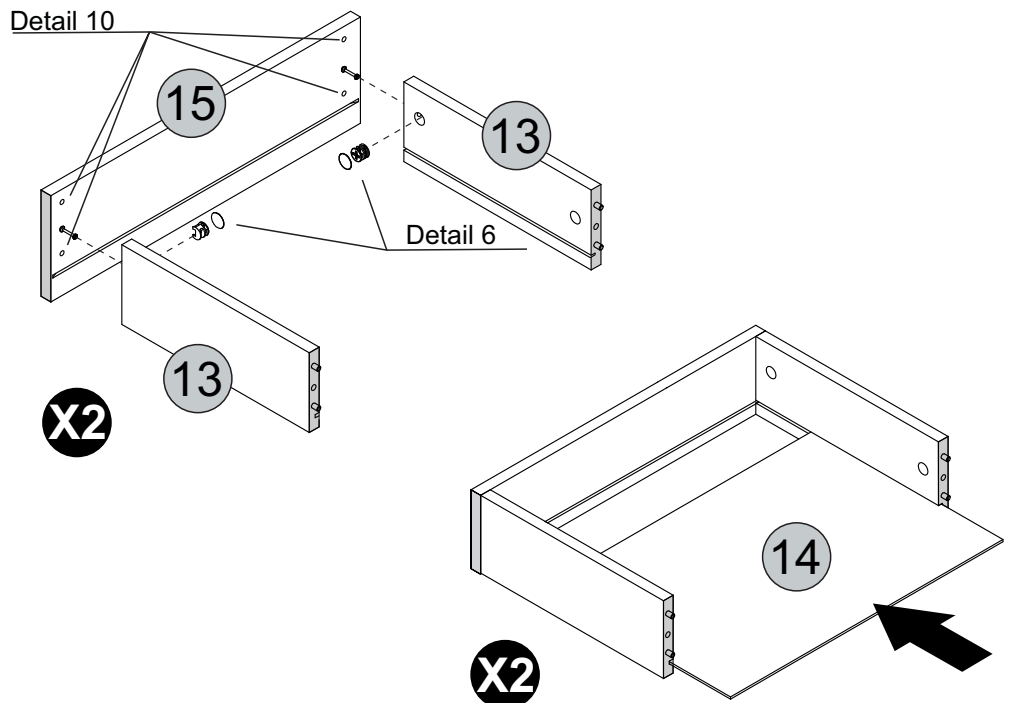
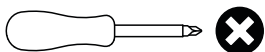

STEP 21

PARTS REQUIRED

11 - LOWER DRAWER FRONT x2

12 - DRAWER FRONT x2

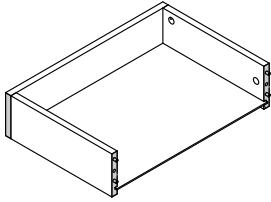

HARDWARE REQUIRED

C  04

L  04

TOOLS REQUIRED

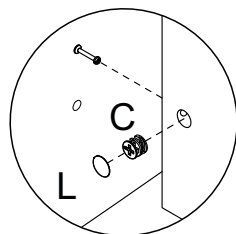
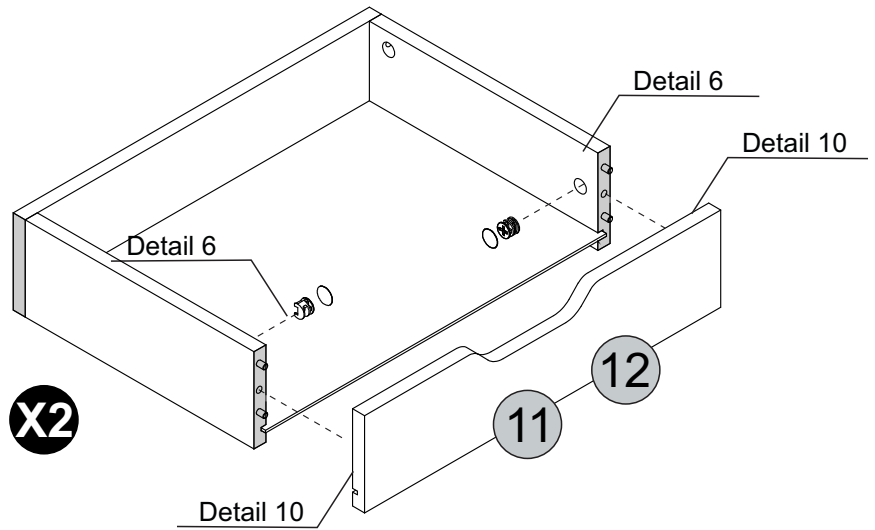
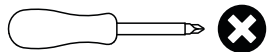

Detail 6

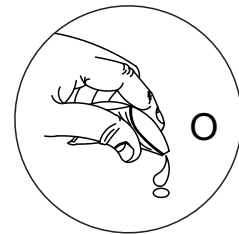
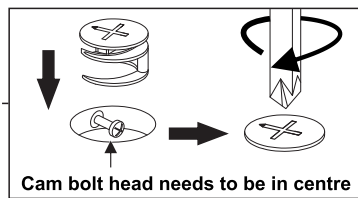

Detail 10

STEP 22

PARTS REQUIRED

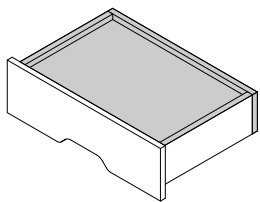

HARDWARE REQUIRED

G  08

K  04

TOOLS REQUIRED

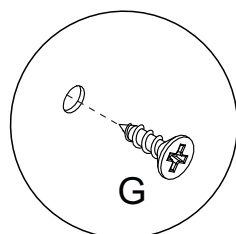
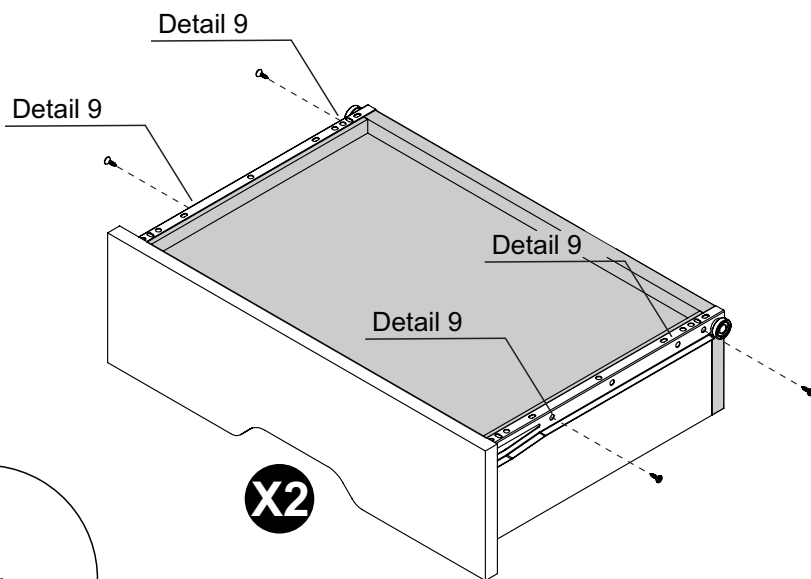
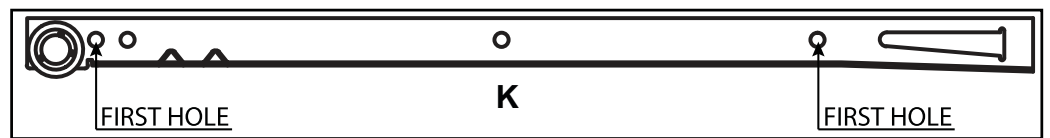
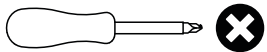

Detail 9

STEP 21

SEC/SH/06/22/AY1

PARTS REQUIRED

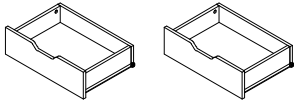
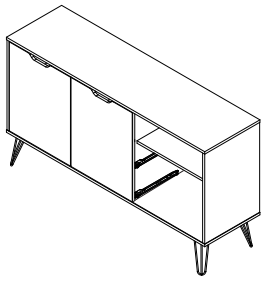

HARDWARE REQUIRED

TOOLS REQUIRED

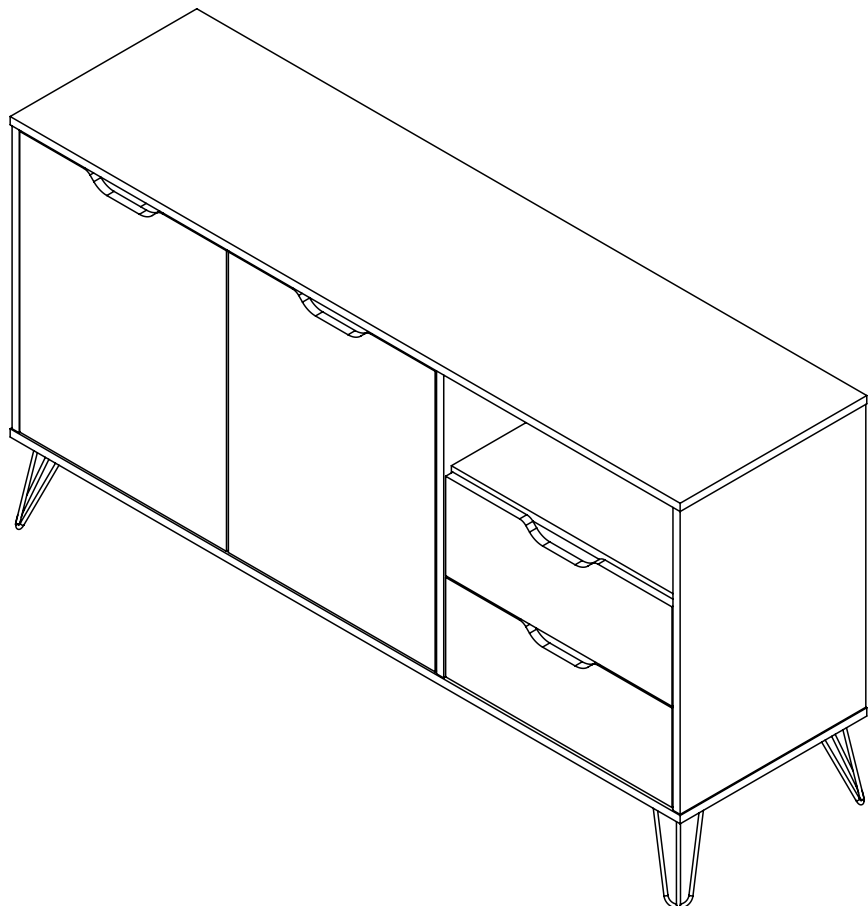
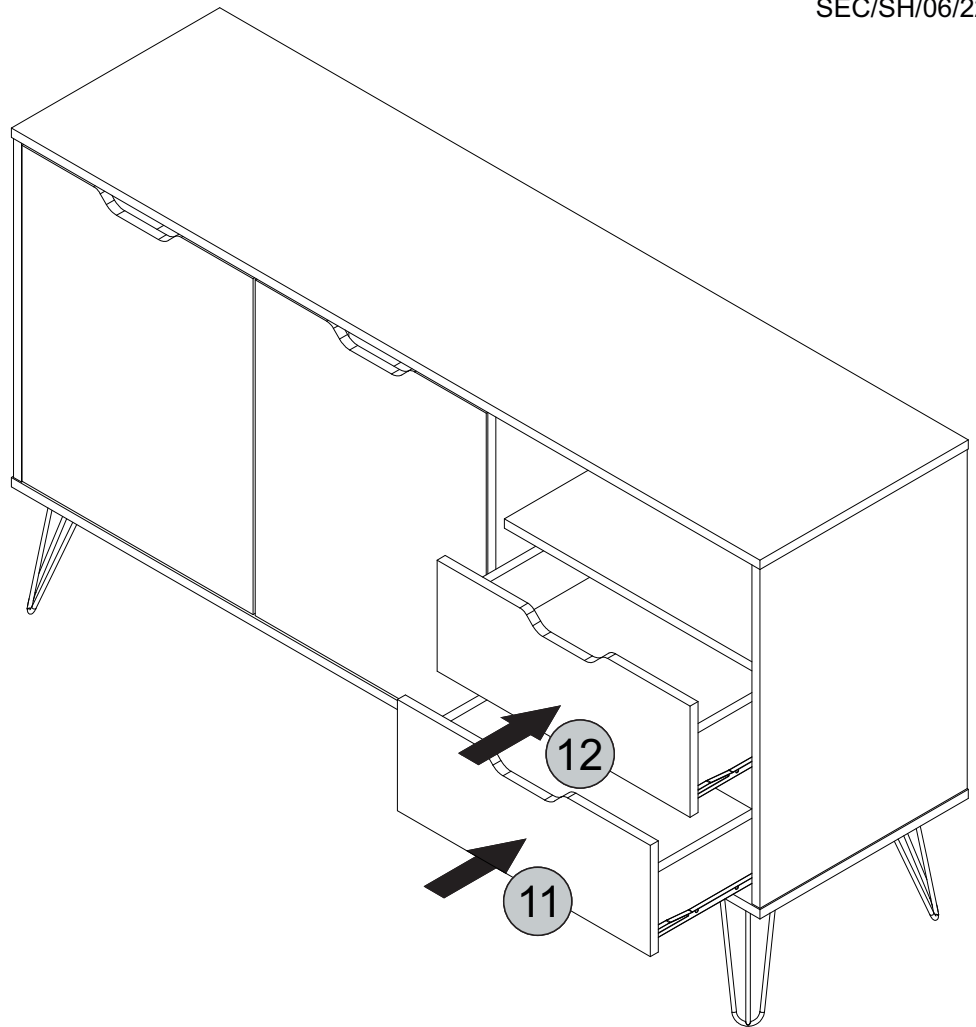



WARNING

Serious or fatal injuries can occur from furniture tipping over. To prevent the furniture from tipping over we recommend that it is permanently fixed to the wall.

Wall fixings are not supplied with this product as different wall materials require different types of fixing devices.

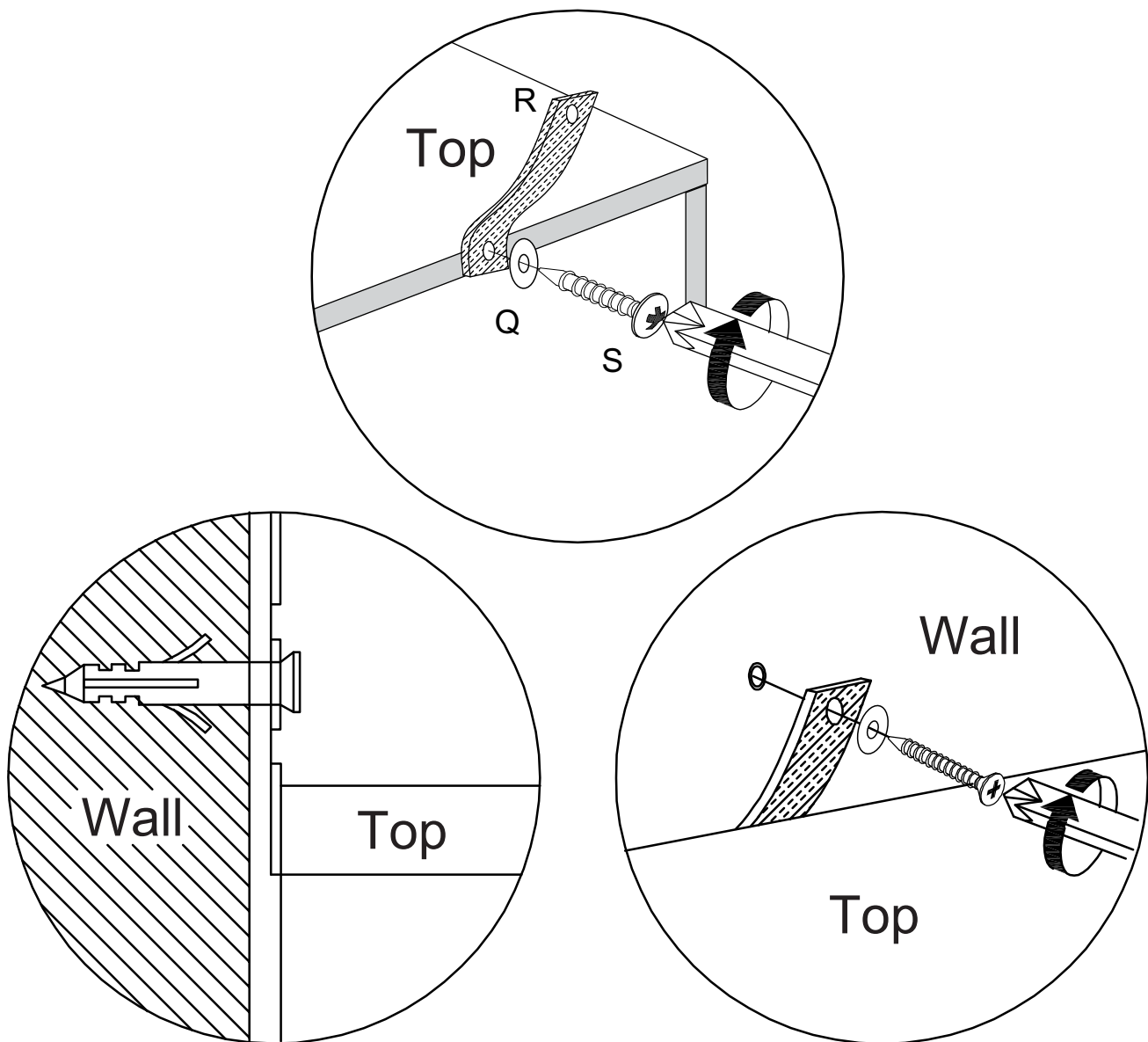
Please make sure you use fixings suitable for the walls in your home.

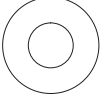
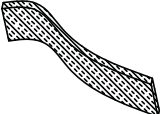

Q  Washer (4x)	R  Strap (2x)	S  Pan Head Screw Ø4 x 14mm (2x)
--	---	---