

DIXIE 2 DOOR WARDROBE ASSEMBLY INSTRUCTIONS

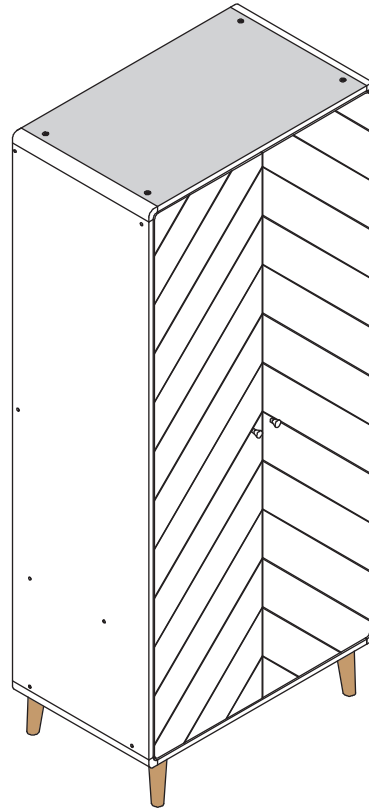

**FOR DOMESTIC USE ONLY
IMPORTANT**

PLEASE READ BEFORE YOU CONTINUE FURTHER

THE PRODUCT YOU HAVE PURCHASED WILL GIVE YOU MANY YEARS OF SERVICE IF YOU FOLLOW THE GUIDELINES FOR ITS SAFE ASSEMBLY AND PERIODIC MAINTENANCE AND CLEANING.

ASSEMBLE ON A SOFT CLEAN SURFACE.

DO NOT USE ANY TOOLS OTHER THAN THOSE SHOWN.

ANY SPANNERS OR ALLEN KEYS REQUIRED ARE INCLUDED WITH THE FITTING KIT.

DO NOT FOR ANY REASON USE A POWER TOOL TO ASSEMBLE THIS PRODUCT. ITS USE WILL INVALIDATE ANY CLAIM YOU MAY HAVE AND COULD MAKE THIS PRODUCT UNSAFE.

DEPENDING ON THE AMOUNT OF USE THIS PRODUCT RECEIVES, IT MAY BE NECESSARY TO TIGHTEN UP THE FIXINGS FROM TIME TO TIME. THIS IS COMPLETELY NORMAL FOR ANY FLAT PACK FURNITURE. DO NOT OVERTIGHTEN FIXINGS.

FOR CLEANING, YOU MAY USE A DAMP CLOTH (NOT WET). DO NOT USE POLISH, DETERGENT OR CHEMICAL CLEANERS.



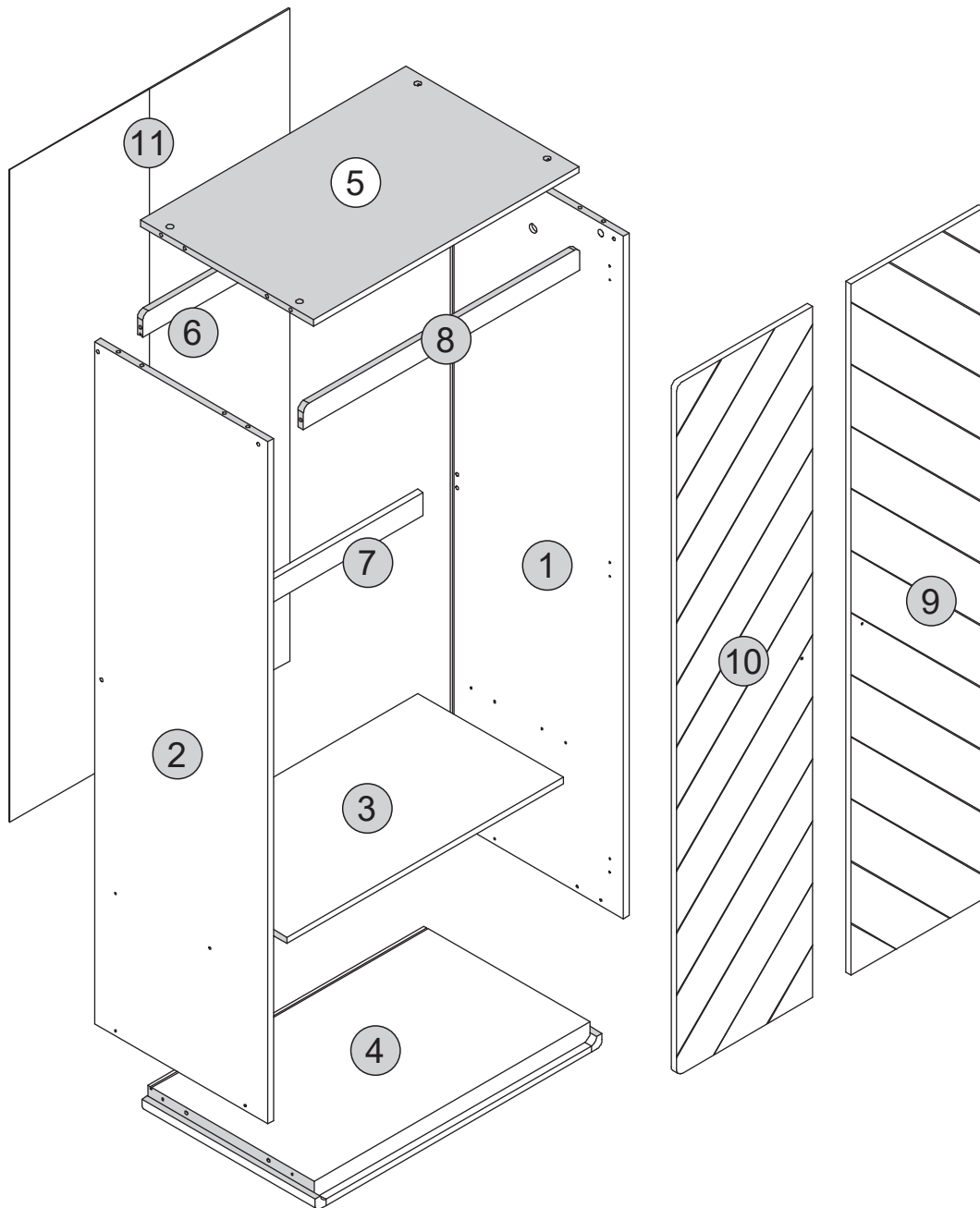













THIS SURFACE OF THIS ITEM IS NOT HEAT RESISTANT. ALWAYS USE A PLACE MAT UNDER HOT OR COLD ITEMS TO PREVENT MARKING.



PART LIST

Part Number	Part Code	Part Description	Quantity	Carton
1	S100-101-176-ZF1-01	Right Side Panel	1	1/2
2	S100-101-176-ZF1-02	Left Side Panel	1	1/2
3	S100-101-176-ZF1-03	Shelf Panel	1	2/2
4	S100-101-176-ZF1-04	Bottom Panel	1	2/2
5	S100-101-176-ZF1-05	Top Panel	1	2/2
6	S100-101-176-ZF1-06	Back Support Panel	1	2/2
7	S100-101-176-ZF1-07	Centre Support Panel	1	2/2
8	S100-101-176-ZF1-08	Front Support Panel	1	2/2
9	S100-101-176-ZF1-09	Right Door	1	1/2
10	S100-101-176-ZF1-10	Left Door	1	1/2
11	S100-101-176-ZF1-11	Back Panel	1	1/2

HARDWARE LIST

No	Part Name		Qty	Carton
A	M8x30mm Wooden Dowel		x18	1
B	Minifix Cam Bolt <small>(8032t)</small>		x8	1
C	Minifix Cam Nut <small>(1512)</small>		x8	1
D	M6.3x40mm Unitar Screw		x14	1
E	M3.5x16mm Screw		x28	1
F	M4x20mm Screw		x20	1
G	M4x25mm Screw		x2	1
H	Handle		x2	1
I	End Hinges <small>(M11)</small>		x6	1
J	PVC L-Bracket		x1	1
K	Screw Cover <small>(Sticker 22mm)</small>		x18	1
L	PVC Leg 160mm		x4	2
M	Corner Support <small>(AC101)</small>		x2	1
N	Allen Key M4		x1	1
O	Joining Panel <small>(470x30x30mm)</small>		x2	1
P	Wall Fixing <small>(4x20mm=1pc)</small>		x1	1
Q	Hanging Rail <small>(764mm)</small>		x1	1

TIPS FOR FITTINGS CAM-LOCKS

WHEN FITTING CAM NUT. ENSURE STARTING POSITION IS CORRECT BEFORE YOU INSERT CONNECTING CAM BOLT TURN CLOCKWISE UNTIL SECURE

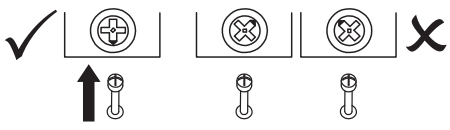

CORRECT
WRONG

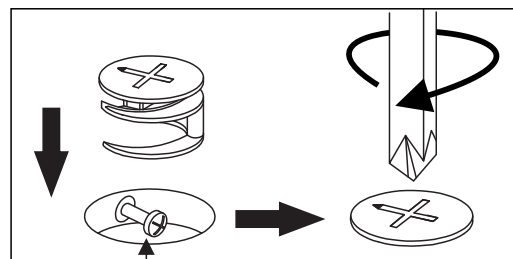

Cam bolt head needs to be in centre

CAMBOLT

Tighten until shoulder in flush with panel. Do not overtighten or undertighten (see example below)

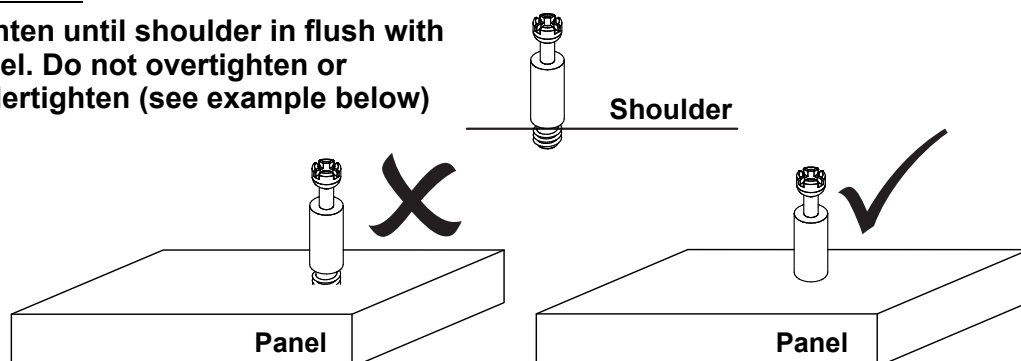

STEP 1

PARTS REQUIRED

3 - SHELF PANEL x1

4 - BOTTOM PANEL x1

5 - TOP PANEL x1

7 - SUPPORT PANEL x1

HARDWARE REQUIRED

A  18

B  08

E  01
3.5x16mm

J  01

O  02

TOOLS REQUIRED

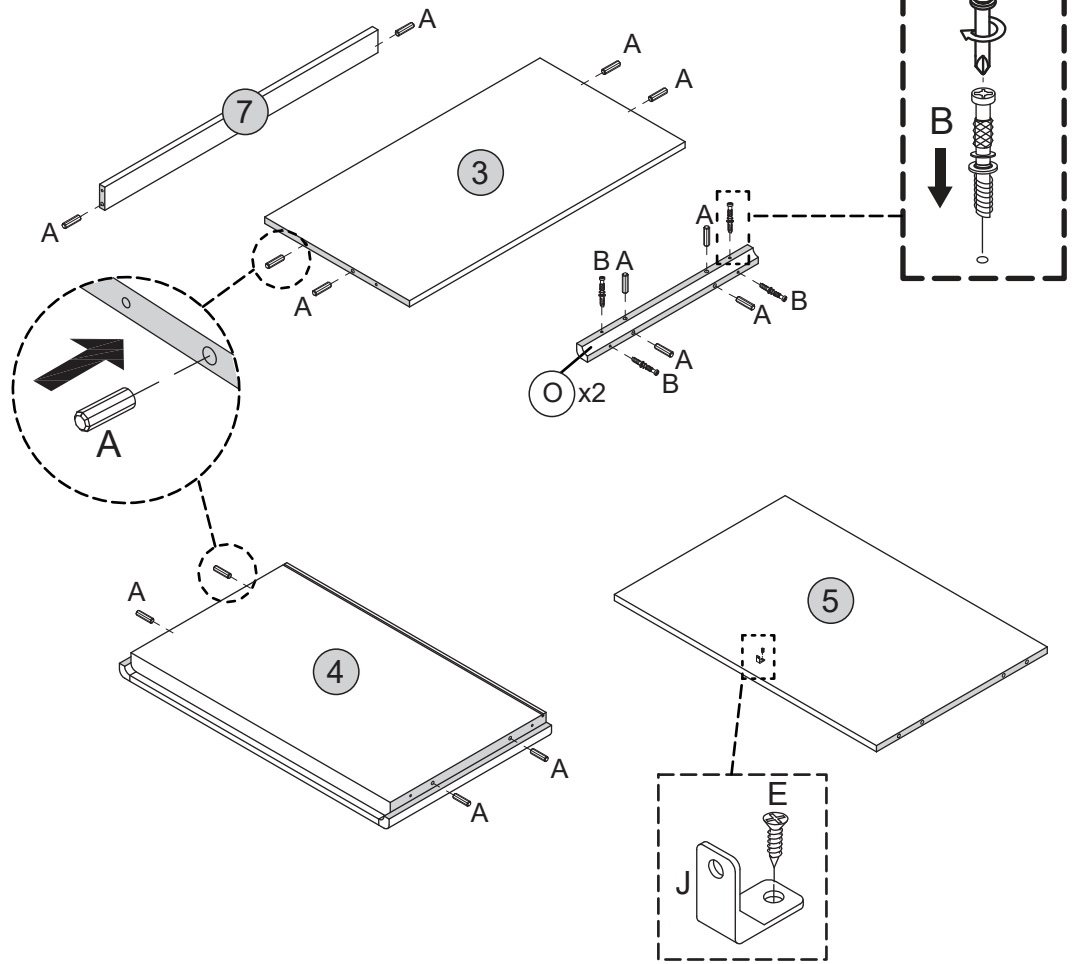
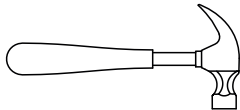
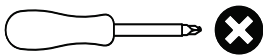

STEP 2

PARTS REQUIRED

1 - RIGHT RIGHT SIDE PANEL x1

2 - LEFT SIDE PANEL x1

5 - TOP PANEL x1

HARDWARE REQUIRED

C  08

TOOLS REQUIRED

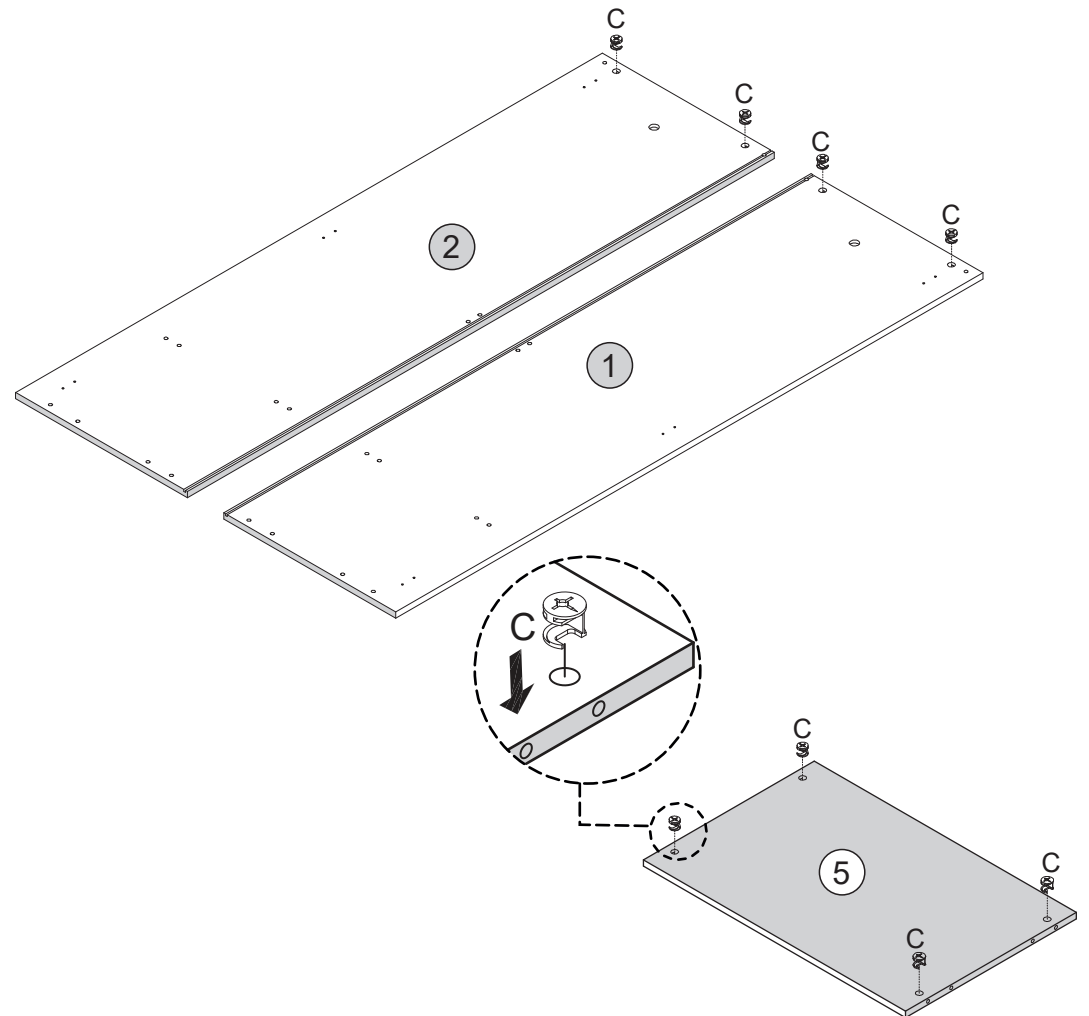

STEP 3

PARTS REQUIRED

- 1 - RIGHT SIDE PANEL x1
- 2 - LEFT SIDE PANEL x1

HARDWARE REQUIRED

- K  04

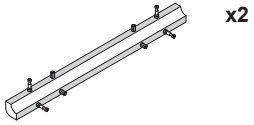

TOOLS REQUIRED

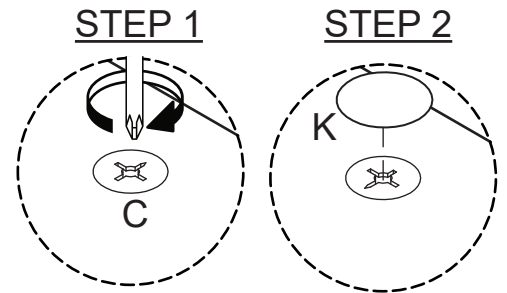
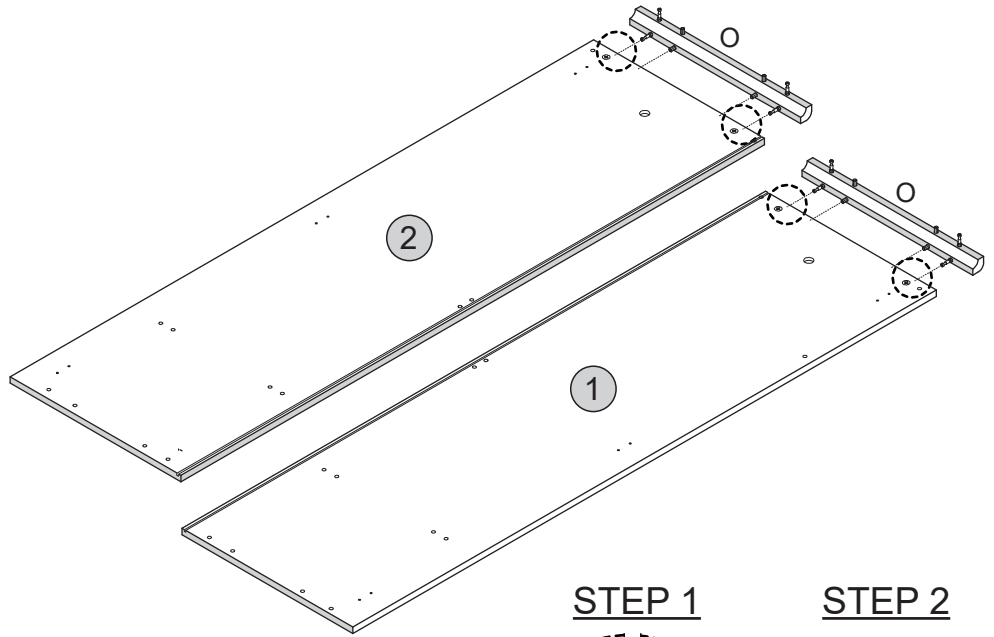
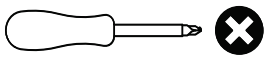

STEP 4

PARTS REQUIRED

- 9 - RIGHT DOOR x1
- 10 - LEFT DOOR x1

HARDWARE REQUIRED

- E  12
3.5x16mm

- I  06

TOOLS REQUIRED

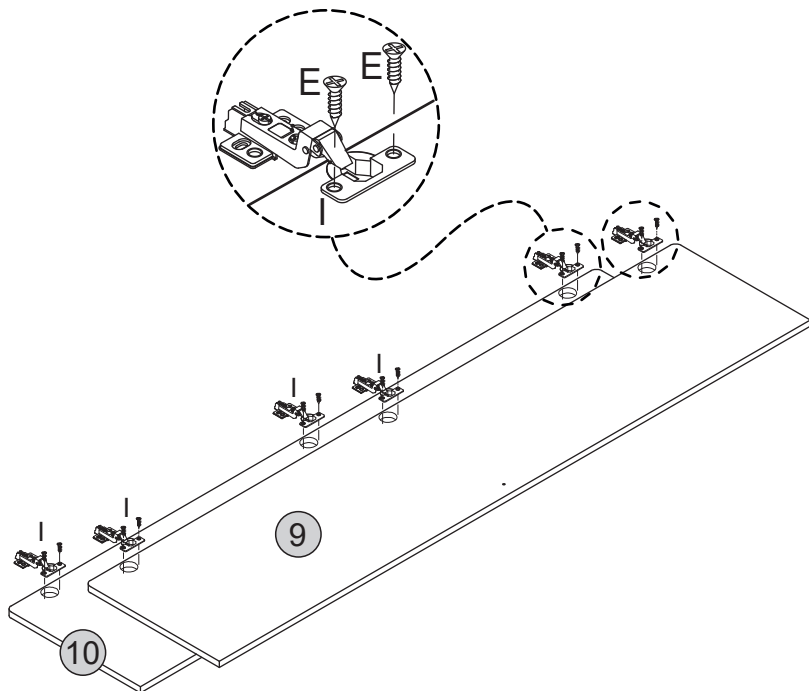
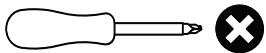



STEP 5

PARTS REQUIRED

- 1 - RIGHT SIDE PANEL x1
- 3 - SHELF PANEL x1
- 4 - BOTTOM PANEL x1
- 6 - BACK SUPPORT PANEL x1
- 7 - SUPPORT PANEL x1
- 8 - FRONT SUPPORT PANEL x1

HARDWARE REQUIRED

- D  07
- K  07

TOOLS REQUIRED

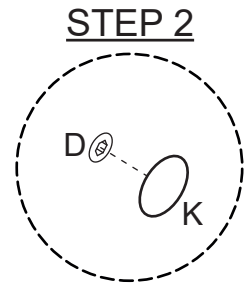
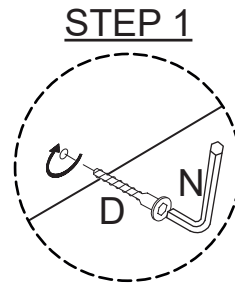
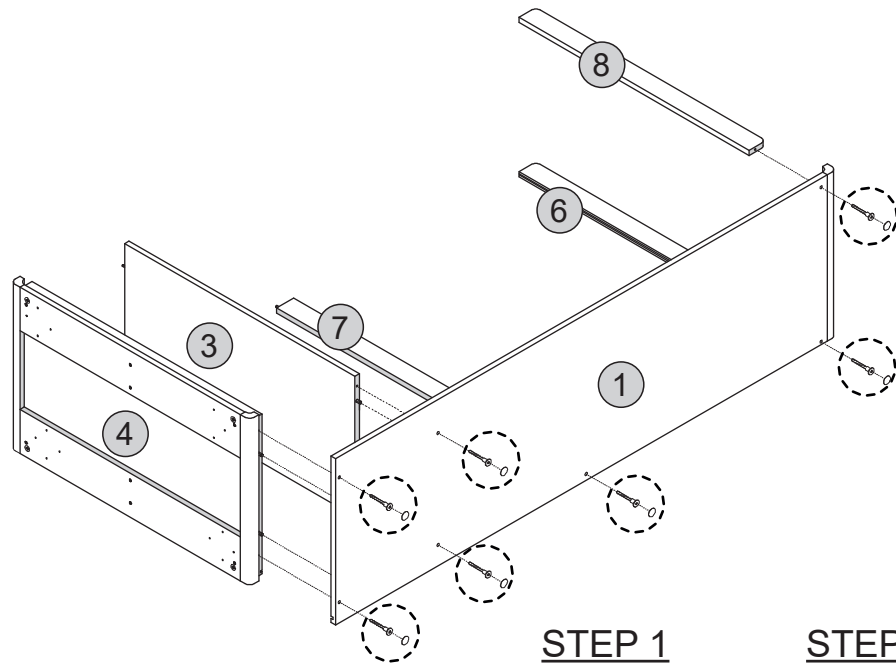

STEP 6

PARTS REQUIRED

- 5 - TOP PANEL x1

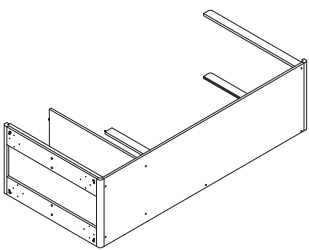

HARDWARE REQUIRED

TOOLS REQUIRED

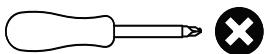

TOP VIEW

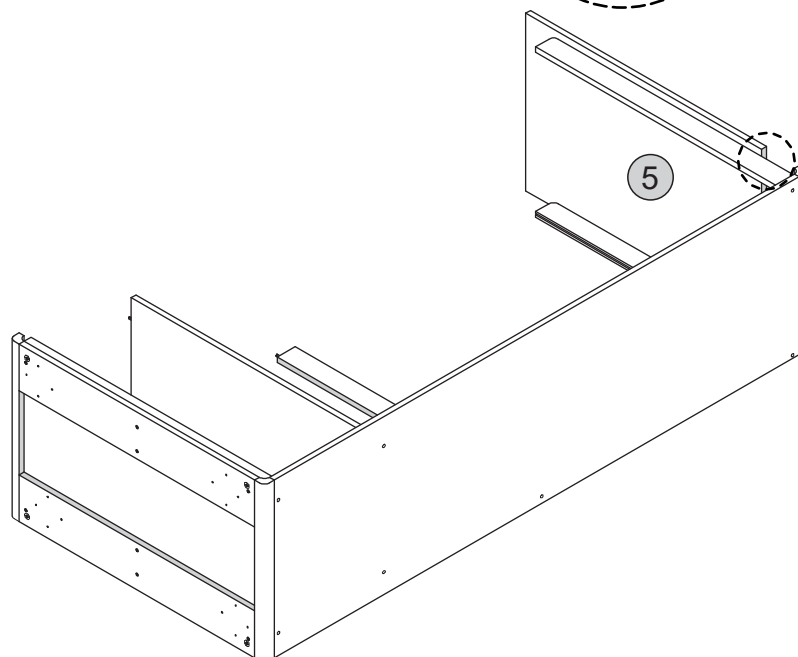
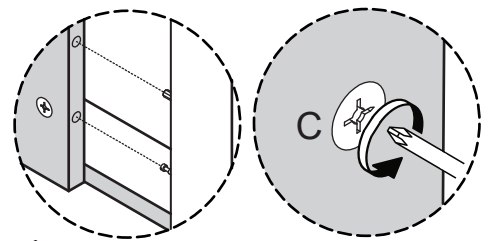

STEP 7

PARTS REQUIRED

11 - BACK PANEL x1

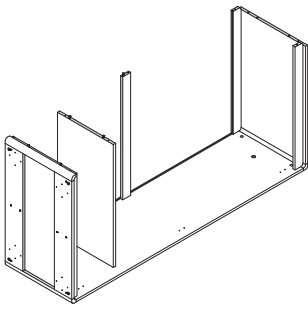

HARDWARE REQUIRED

Q  01

TOOLS REQUIRED

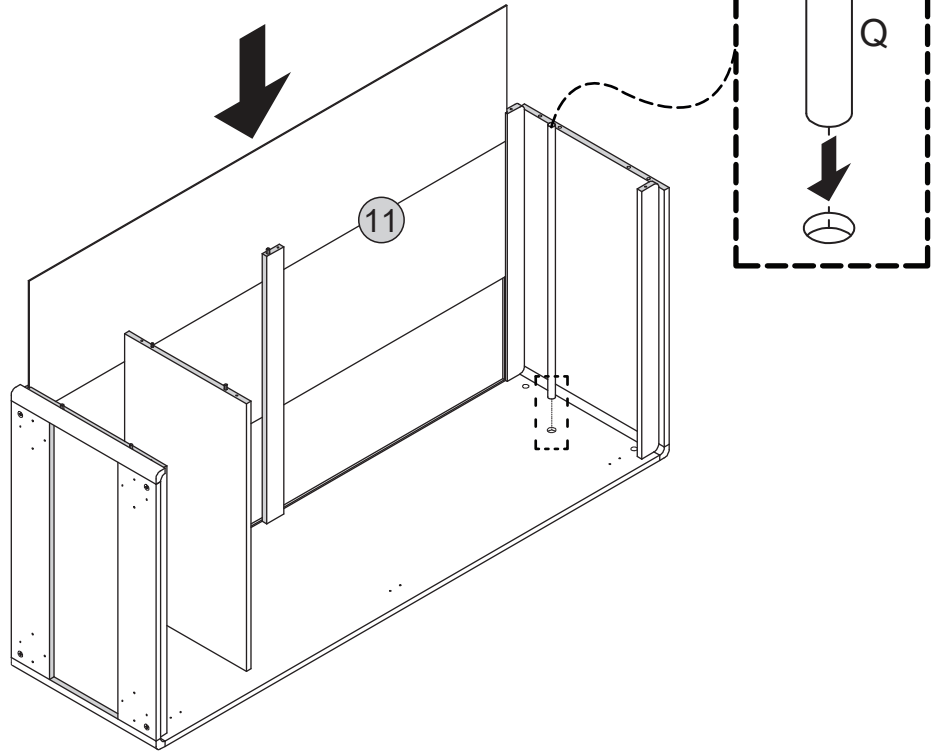

STEP 8

PARTS REQUIRED

2 - LEFT SIDE PANEL x1

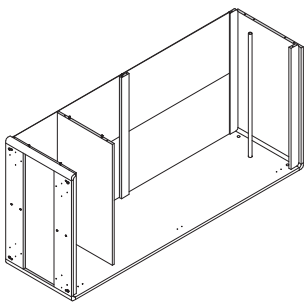

HARDWARE REQUIRED

D  07

K  07

TOOLS REQUIRED

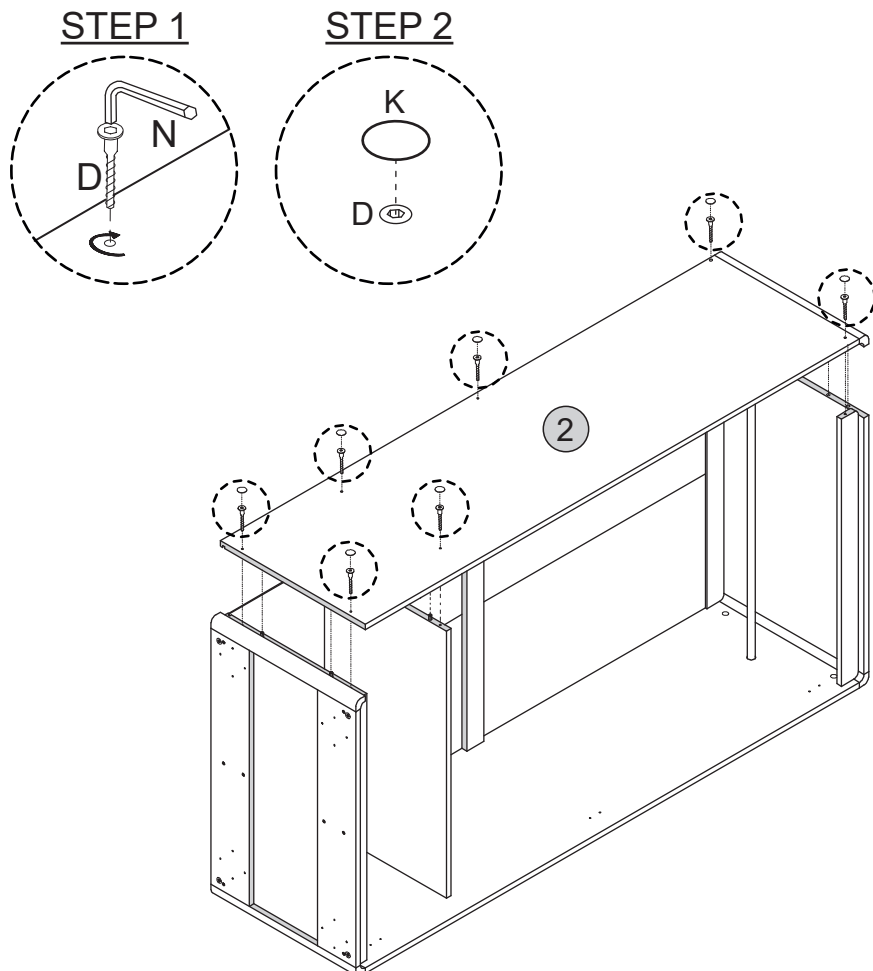
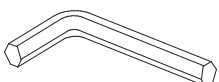

STEP 9

PARTS REQUIRED

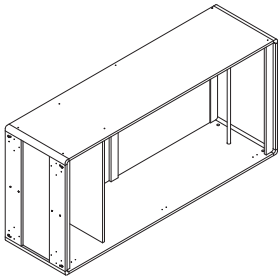

HARDWARE REQUIRED

E		01
3.5x16mm		

TOOLS REQUIRED

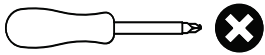

TOP VIEW

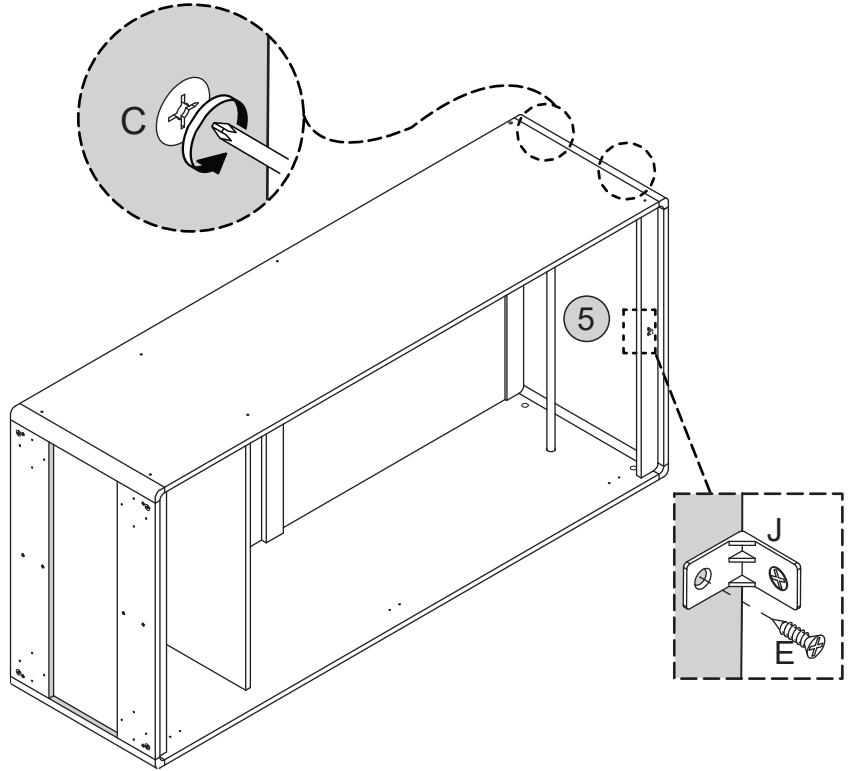

STEP 10

PARTS REQUIRED

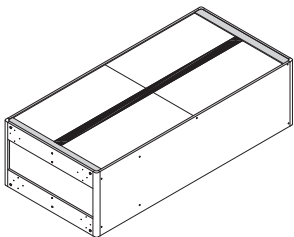

HARDWARE REQUIRED

E		02
3.5x16mm		

F		20
4x20mm		

L		04
---	---	----

M		02
---	---	----

TOOLS REQUIRED

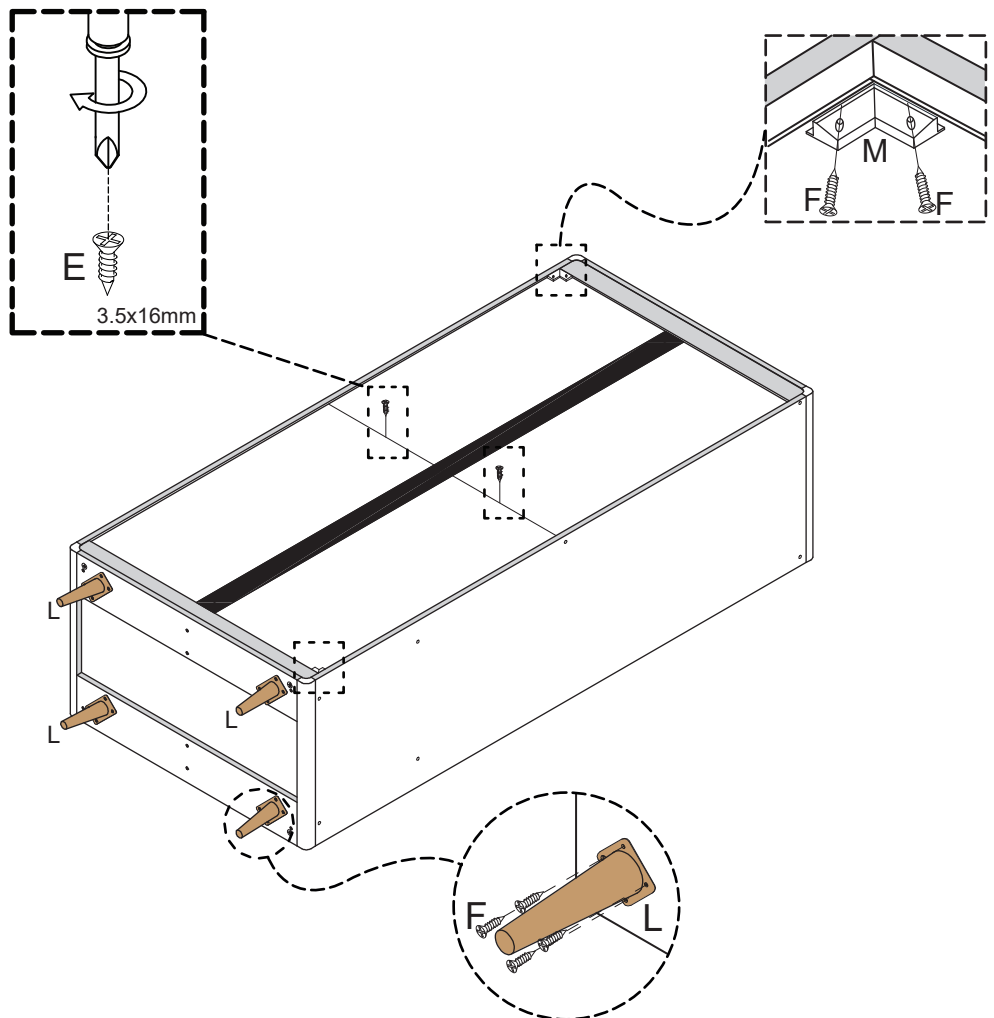
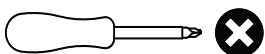

STEP 11

PARTS REQUIRED

9 - RIGHT DOOR x1

10 - LEFT DOOR x1

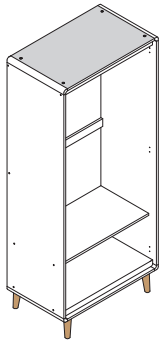

HARDWARE REQUIRED

E  3.5x16mm 12

G  4x25mm 02

H  02

TOOLS REQUIRED

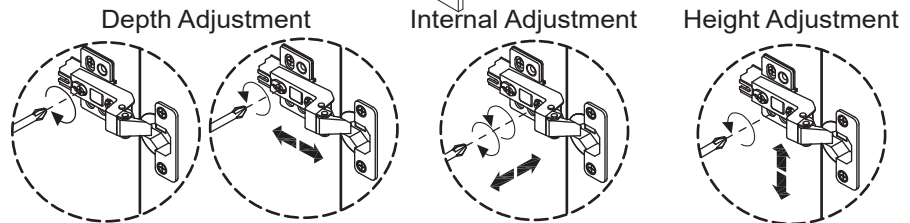
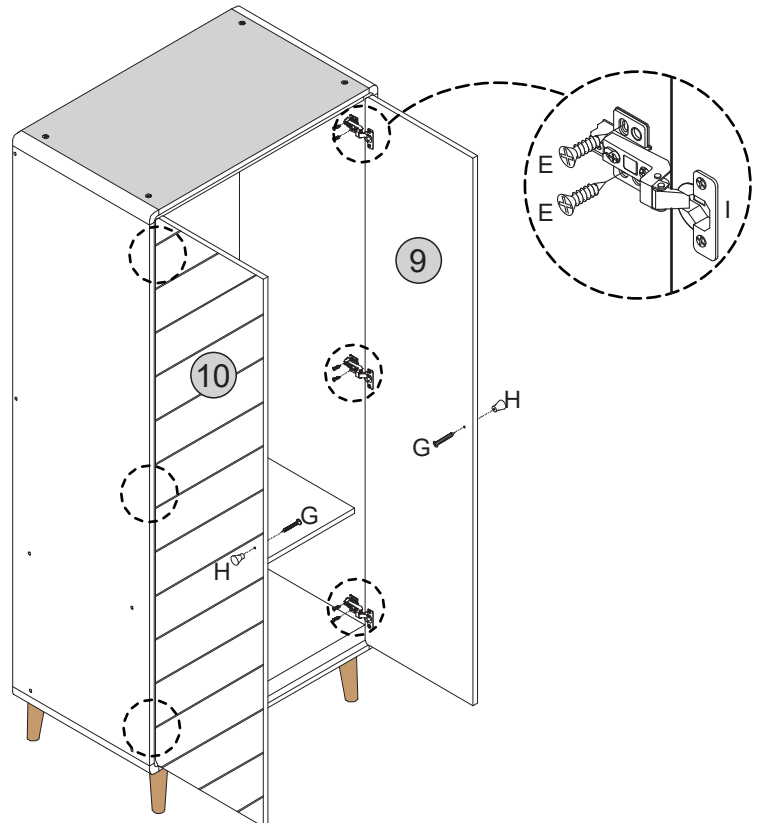
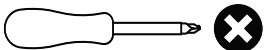

STEP 12

PARTS REQUIRED

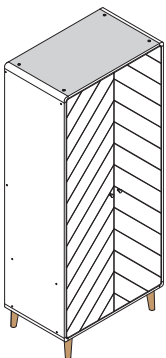

HARDWARE REQUIRED

P  01

TOOLS REQUIRED

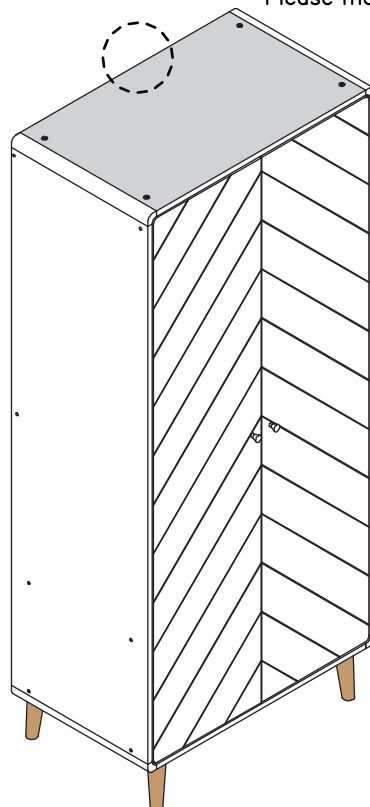
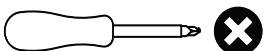

WARNING

Serious or fatal injuries can occur from furniture tipping over. To prevent the furniture from tipping over we recommend that it is permanently fixed to the wall.

Wall fixings are not supplied with this product as different wall materials require different types of fixing devices. Please make sure you use fixings suitable for the walls in your home.

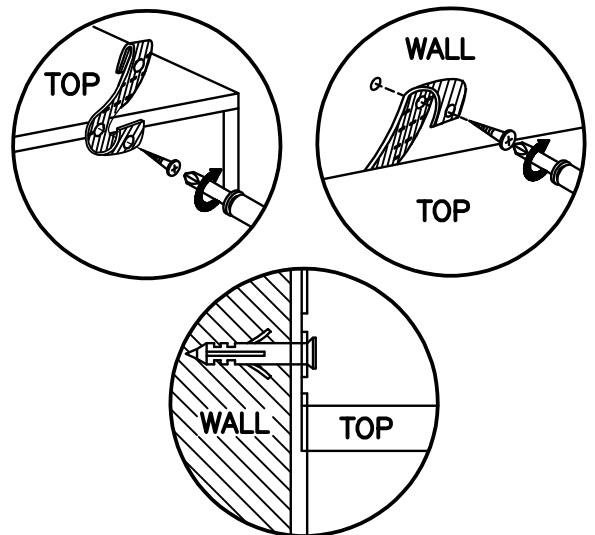

DIXIE 3 DRAWER CHEST ASSEMBLY INSTRUCTIONS

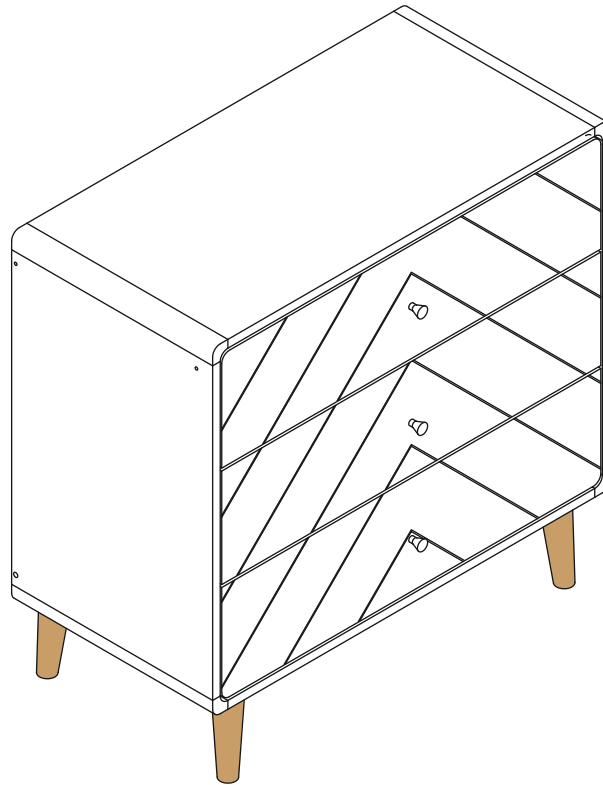

**FOR DOMESTIC USE ONLY
IMPORTANT**

PLEASE READ BEFORE YOU CONTINUE FURTHER

THE PRODUCT YOU HAVE PURCHASED WILL GIVE YOU MANY YEARS OF SERVICE IF YOU FOLLOW THE GUIDELINES FOR ITS SAFE ASSEMBLY AND PERIODIC MAINTENANCE AND CLEANING.

ASSEMBLE ON A SOFT CLEAN SURFACE.

DO NOT USE ANY TOOLS OTHER THAN THOSE SHOWN.

ANY SPANNERS OR ALLEN KEYS REQUIRED ARE INCLUDED WITH THE FITTING KIT.

DO NOT FOR ANY REASON USE A POWER TOOL TO ASSEMBLE THIS PRODUCT. ITS USE WILL INVALIDATE ANY CLAIM YOU MAY HAVE AND COULD MAKE THIS PRODUCT UNSAFE.

DEPENDING ON THE AMOUNT OF USE THIS PRODUCT RECEIVES, IT MAY BE NECESSARY TO TIGHTEN UP THE FIXINGS FROM TIME TO TIME. THIS IS COMPLETELY NORMAL FOR ANY FLAT PACK FURNITURE. DO NOT OVERTIGHTEN FIXINGS.

FOR CLEANING, YOU MAY USE A DAMP CLOTH (NOT WET). DO NOT USE POLISH, DETERGENT OR CHEMICAL CLEANERS.



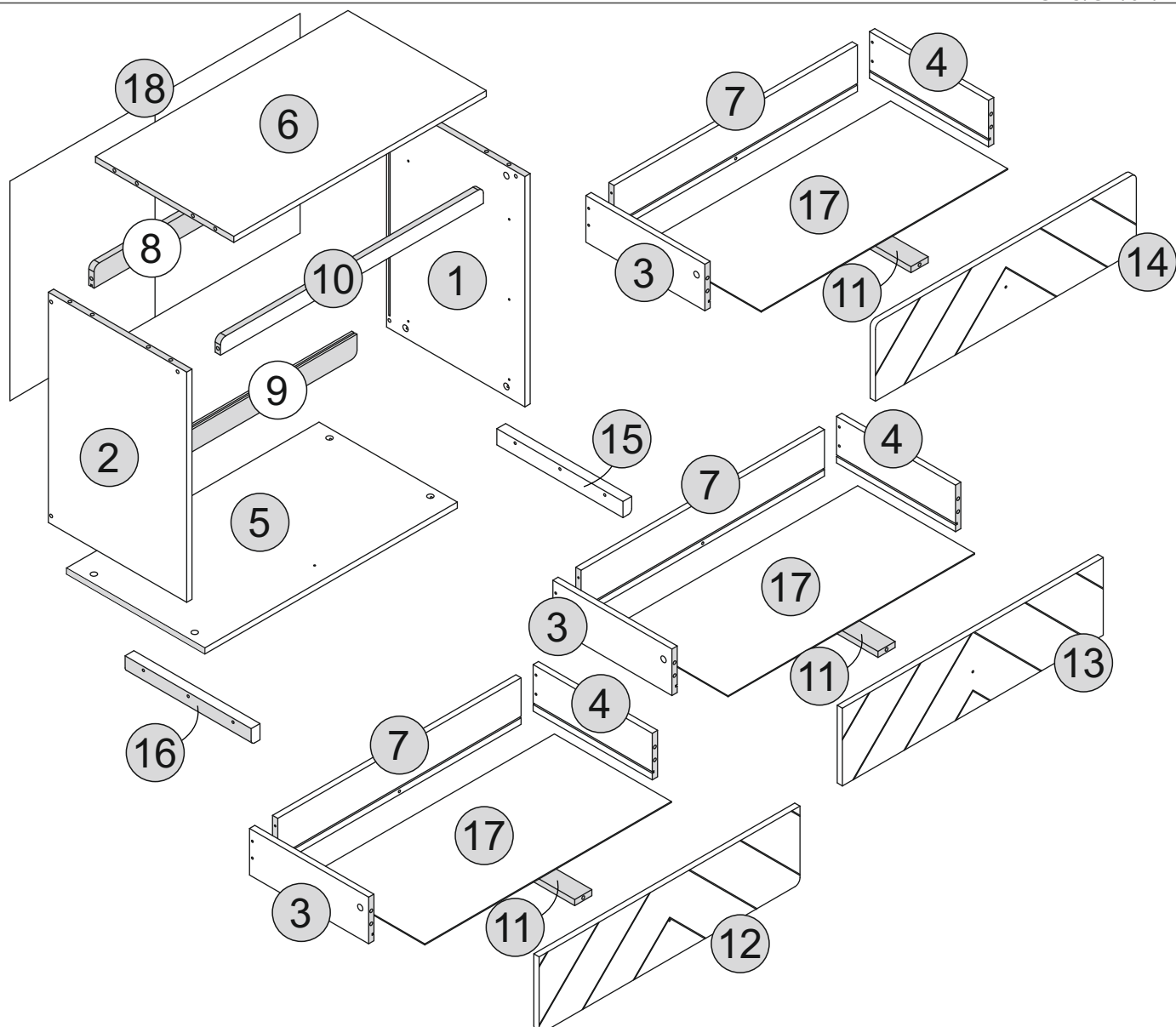









THIS SURFACE OF THIS ITEM IS NOT HEAT RESISTANT. ALWAYS USE A PLACE MAT UNDER HOT OR COLD ITEMS TO PREVENT MARKING.



PART LIST

Part Number	Part Code	Part Description	Quantity	Carton
1	S100-102-157-ZF1-01	Right Side Panel	1	1/1
2	S100-102-157-ZF1-02	Left Side Panel	1	1/1
3	S100-102-157-ZF1-03	Left Drawer Side Panel	3	1/1
4	S100-102-157-ZF1-04	Right Drawer Side Panel	3	1/1
5	S100-102-157-ZF1-05	Bottom Panel	1	1/1
6	S100-102-157-ZF1-06	Top Panel	1	1/1
7	S100-102-157-ZF1-07	Drawer Back Panel	3	1/1
8	S100-102-157-ZF1-08	Top Back Support Panel	1	1/1
9	S100-102-157-ZF1-09	Bottom Back Support Panel	1	1/1
10	S100-102-157-ZF1-10	Front Support Panel	1	1/1
11	S100-102-157-ZF1-11	Drawer Support	3	1/1
12	S100-102-157-ZF1-12	Bottom Drawer Front	1	1/1
13	S100-102-157-ZF1-13	Centre Drawer Front	1	1/1
14	S100-102-157-ZF1-14	Top Drawer Front	1	1/1
15	S100-102-157-ZF1-15	Right Support Panel	1	1/1
16	S100-102-157-ZF1-16	Left Support Panel	1	1/1
17	S100-102-157-ZF1-17	Drawer Base	3	1/1
18	S100-102-157-ZF1-18	Back Panel	1	1/1

HARDWARE LIST

No	Part Name		Qty	Carton
A	M8x30mm Wooden Dowel		x22	1
B	Minifix Cam Bolt <small>(8032t)</small>		x25	1
C	Minifix Cam Nut <small>(1512)</small>		x25	1
D	M6.3x40mm Unitar Screw		x6	1
E	M3.5x16mm Screw		x26	1
F	M4x20mm Screw		x20	1
G	M4x25mm Screw		x3	1
H	Handle		x3	1
I	14" Drawer Slide <small>(VKT 0.9 - W)</small>		x3	1
J	PVC L-Bracket		x1	1
K	Screw Cover <small>(Sticker 22mm)</small>		x6	1
L	PVC Leg 160mm		x4	1
M	Corner Support <small>(AC101)</small>		x2	1
N	Allen Key M4		x1	1
O	Corner Panel <small>(396x30x30mm)</small>		x4	1
P	Wall Fixing <small>(4x20mm=1pc)</small>		x1	1
Q	M4x38mm Screw		x21	1

TIPS FOR FITTINGS CAM-LOCKS

WHEN FITTING CAM NUT. ENSURE STARTING POSITION IS CORRECT BEFORE YOU INSERT CONNECTING CAM BOLT TURN CLOCKWISE UNTIL SECURE

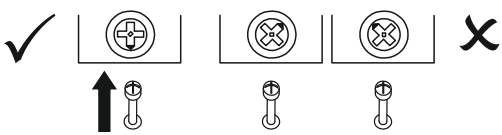

↑
↑
↑

CORRECT
WRONG

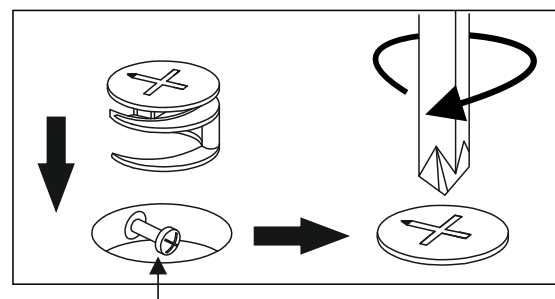

Cam bolt head needs to be in centre

CAMBOLT

Tighten until shoulder in flush with panel. Do not overtighten or undertighten (see example below)

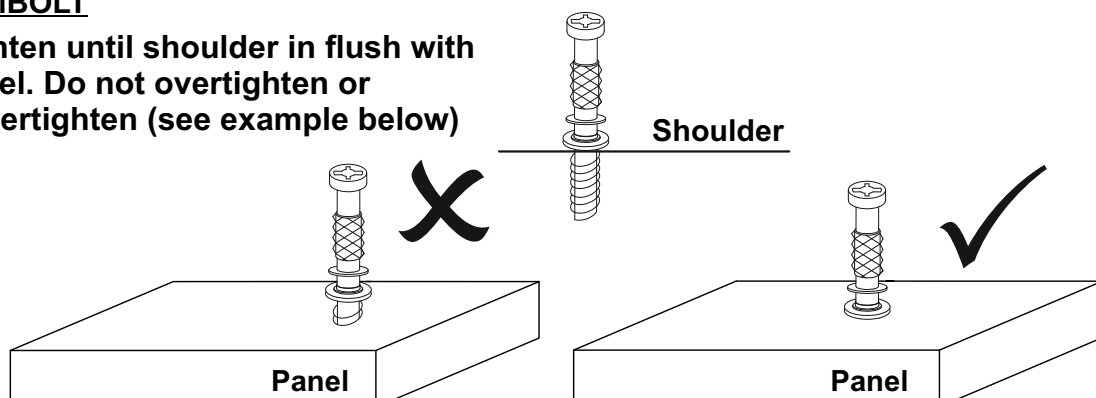



STEP 1

PARTS REQUIRED

6 - TOP PANEL x1

HARDWARE REQUIRED

A  16

B  16

C  04

E  3.5x16mm 01

J  01

O  04

TOOLS REQUIRED

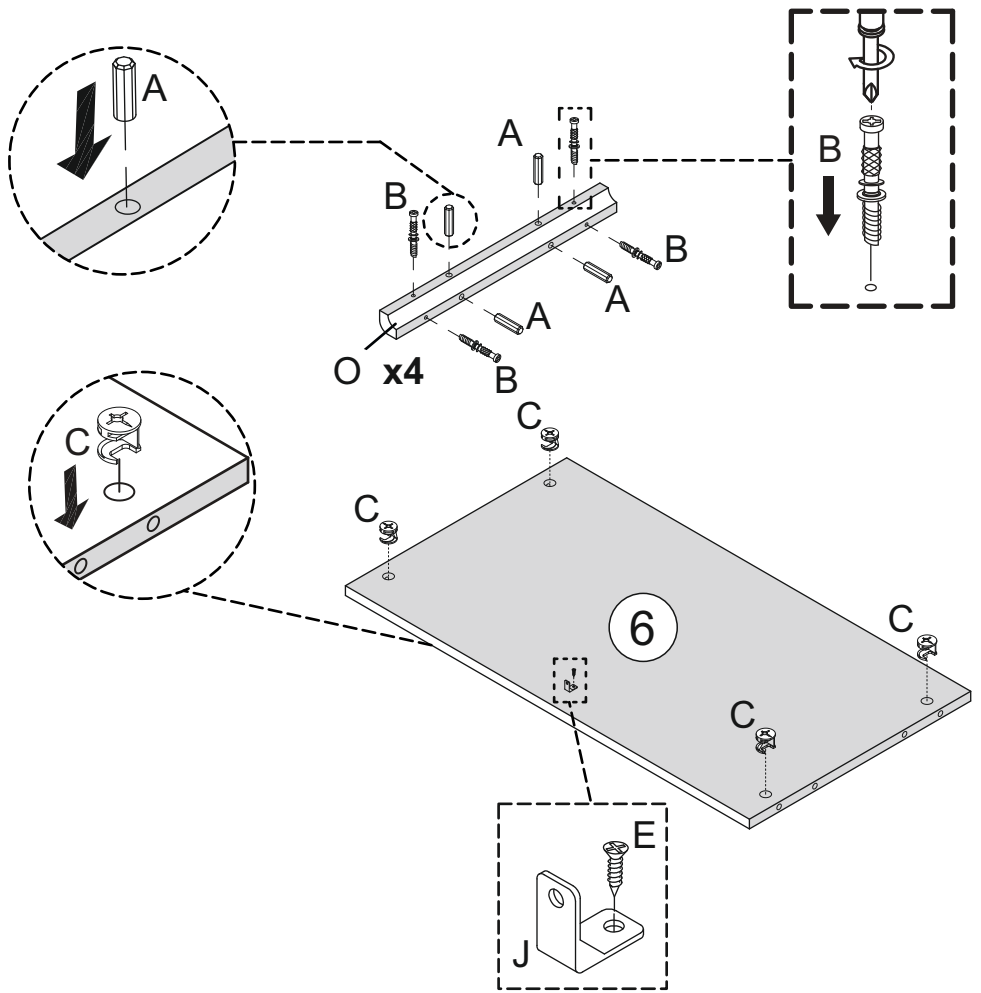
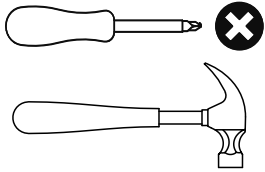

STEP 2

PARTS REQUIRED

1 - RIGHT SIDE PANEL x1

2 - LEFT SIDE PANEL x1

5 - BOTTOM PANEL x1

HARDWARE REQUIRED

C  12

E  3.5x16mm 12

I  03

TOOLS REQUIRED

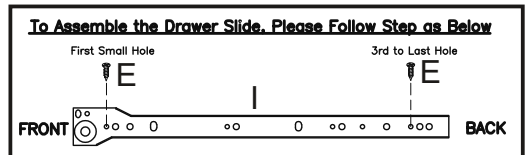
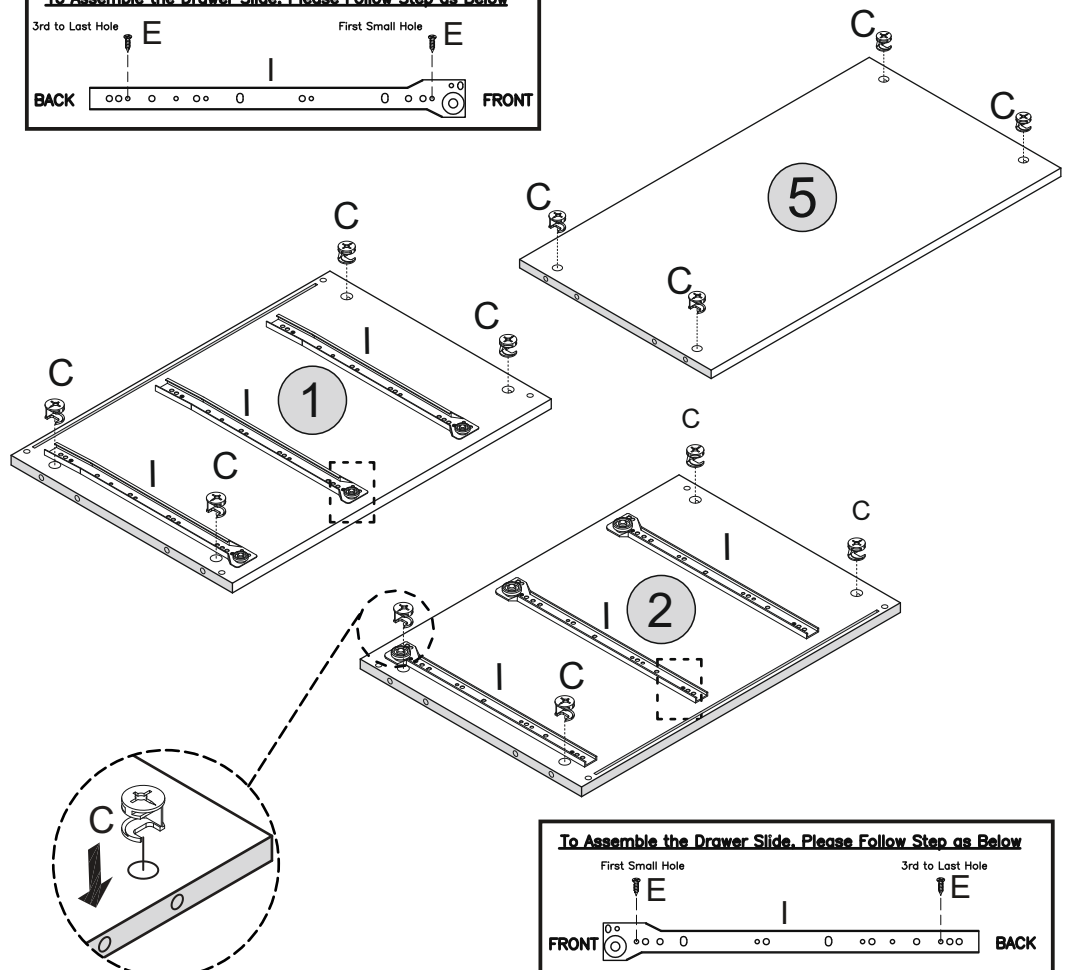
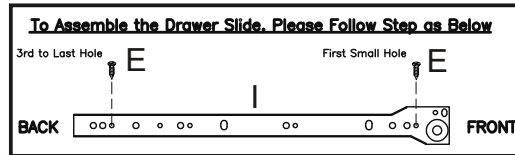
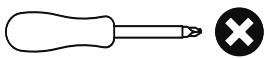

STEP 3

PARTS REQUIRED

- 1 - RIGHT SIDE PANEL x1
- 2 - LEFT SIDE PANEL x1

HARDWARE REQUIRED

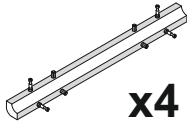

TOOLS REQUIRED

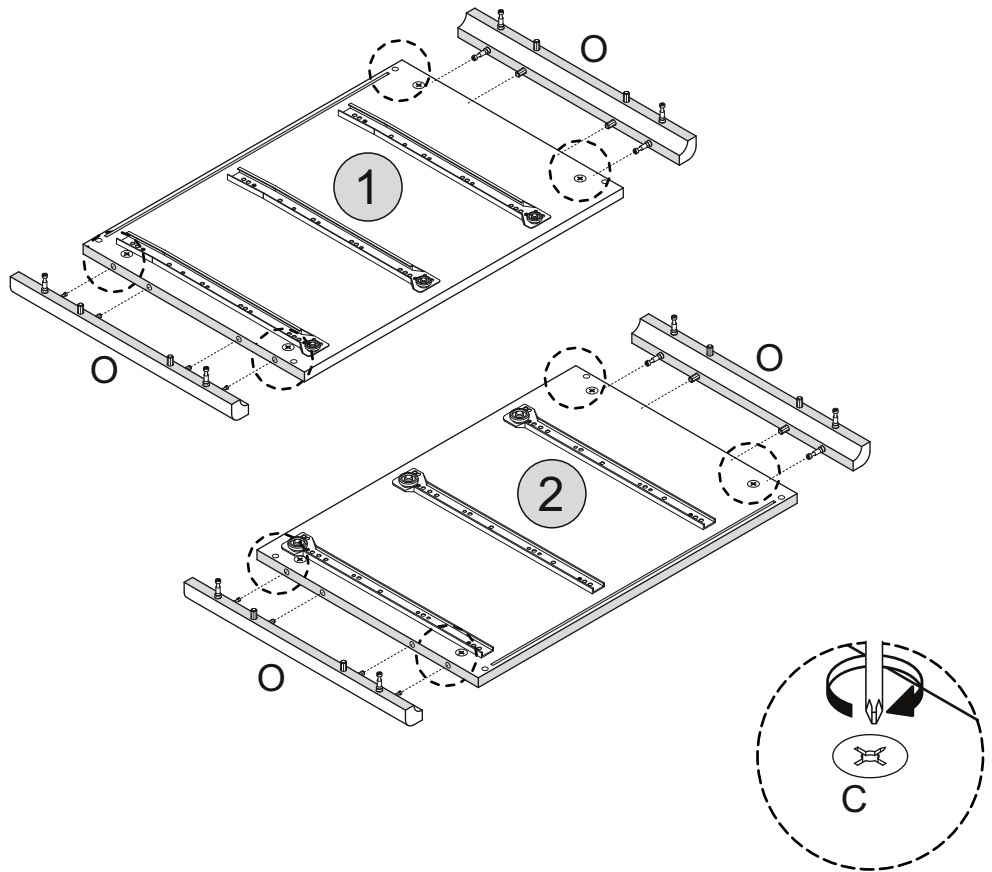
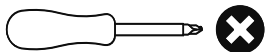

STEP 4

PARTS REQUIRED

- 8 - TOP BACK SUPPORT PANEL x1
- 9 - BOTTOM BACK SUPPORT x1
- 10 - FRONT SUPPORT PANEL x1

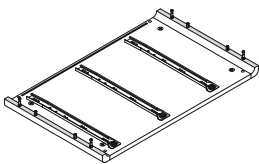

HARDWARE REQUIRED

- D  03

- K  03

TOOLS REQUIRED

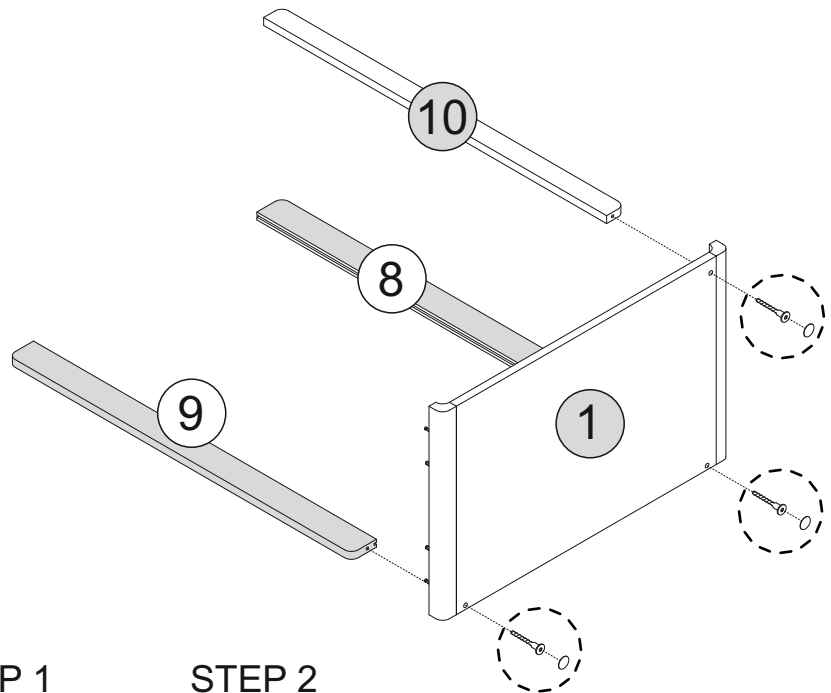
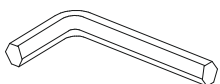

STEP 1

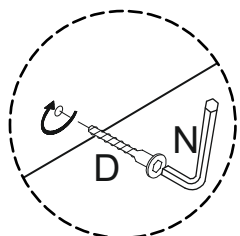

STEP 2

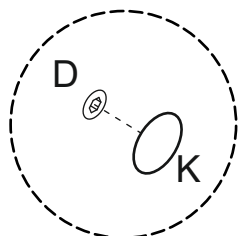

STEP 5

PARTS REQUIRED

5 - BOTTOM PANEL x1

6 - TOP PANEL x1

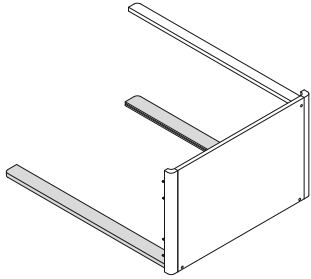

HARDWARE REQUIRED

TOOLS REQUIRED

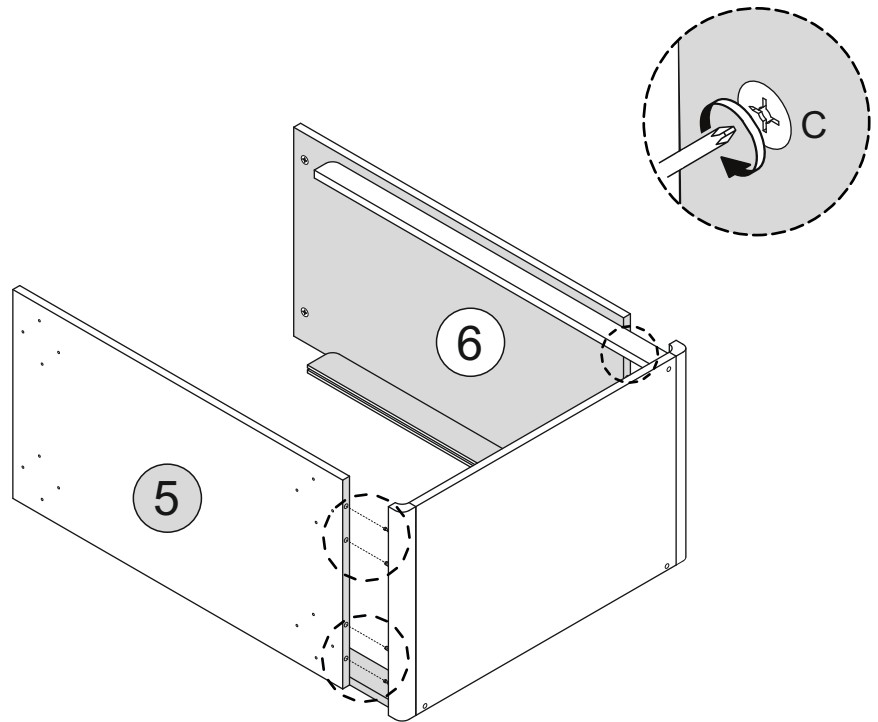
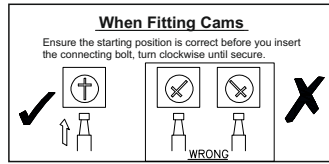
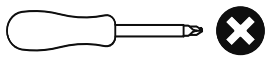

STEP 6

PARTS REQUIRED

18 - BACK PANEL x1

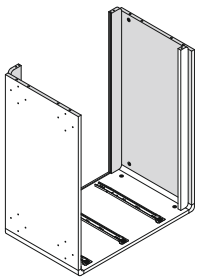

HARDWARE REQUIRED

TOOLS REQUIRED

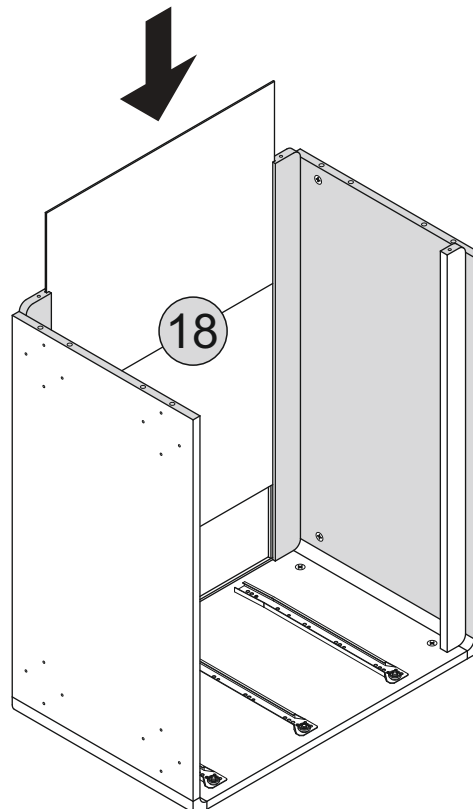

STEP 7

PARTS REQUIRED

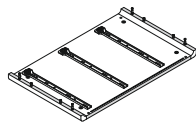
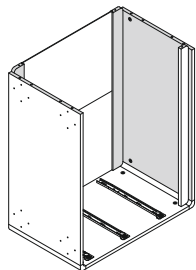

HARDWARE REQUIRED

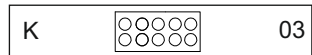

TOOLS REQUIRED

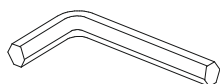

STEP 1

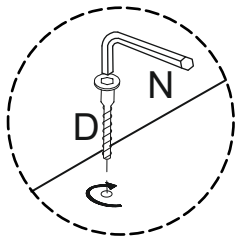

STEP 2

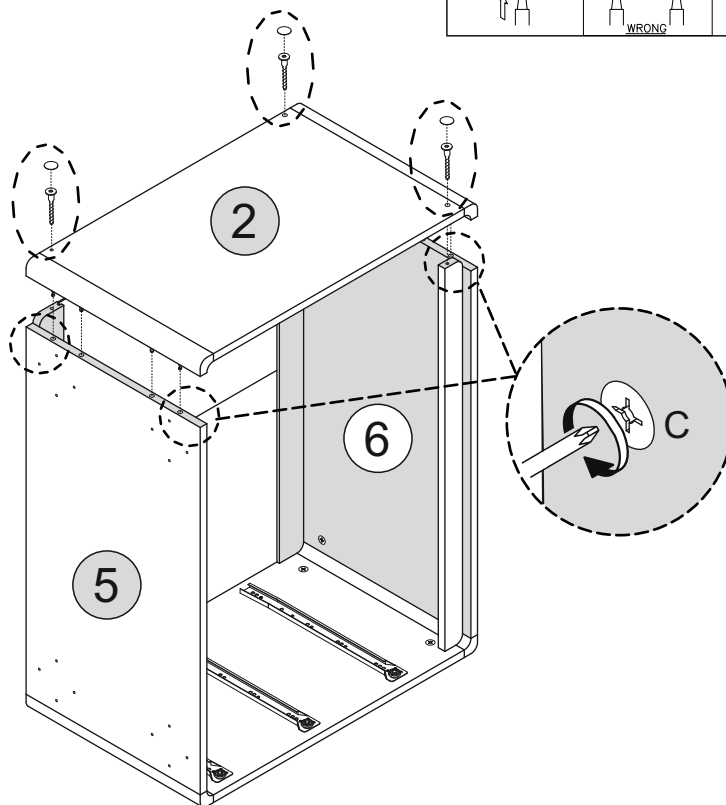
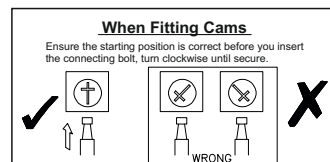
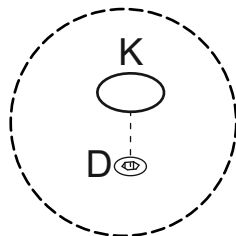

STEP 8

PARTS REQUIRED

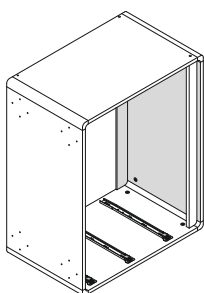

HARDWARE REQUIRED

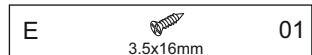

TOOLS REQUIRED

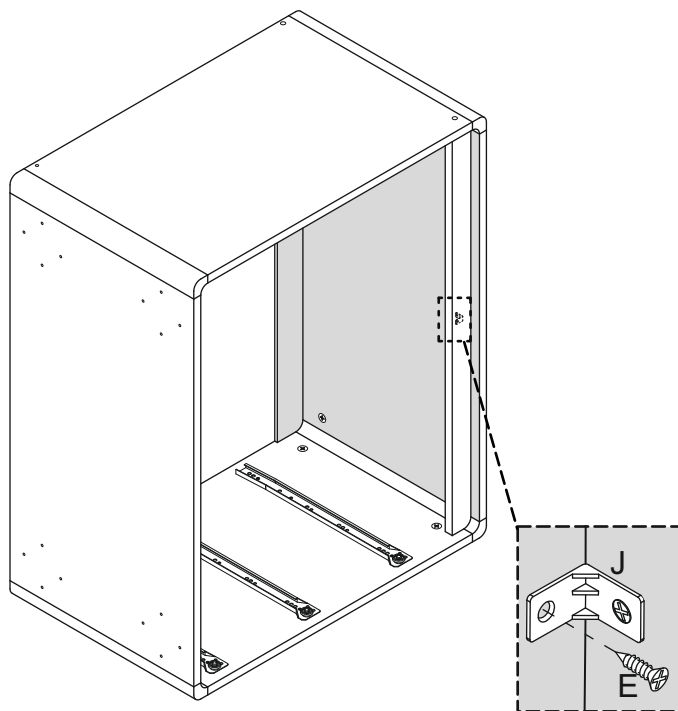
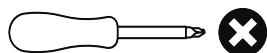

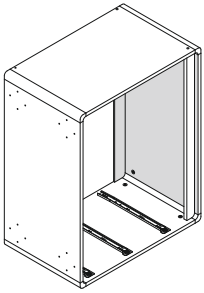

STEP 9

PARTS REQUIRED



HARDWARE REQUIRED

F	 4x20mm	20
L		04
M		02

TOOLS REQUIRED

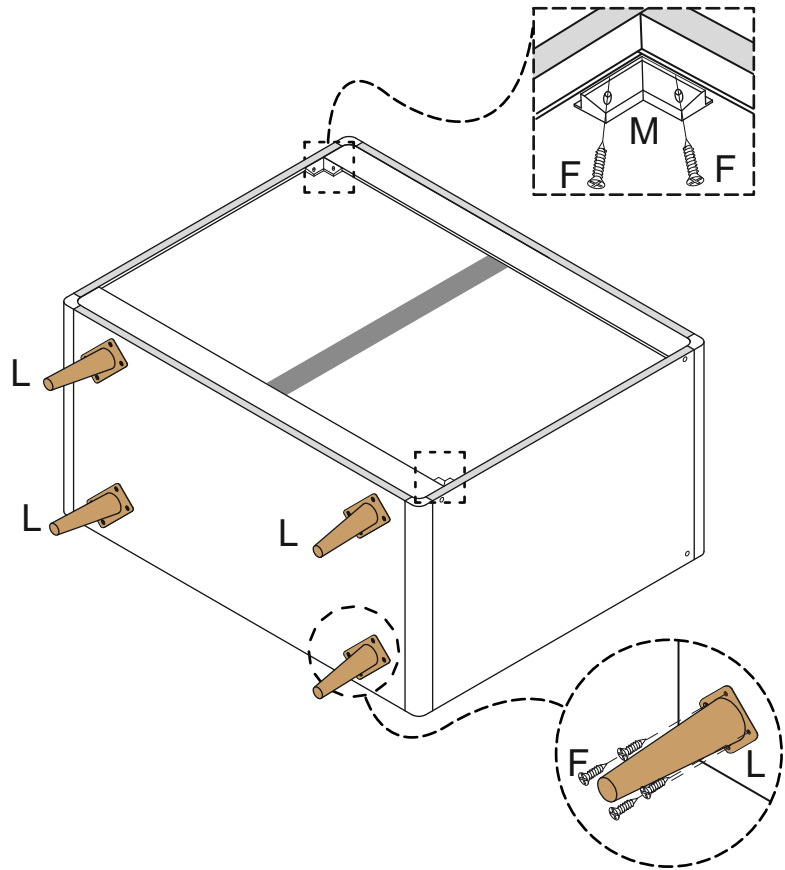
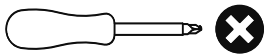



STEP 10

PARTS REQUIRED

3 - LEFT DRAWER SIDE	x3
4 - RIGHT DRAWER SIDE	x3
11 - DRAWER SUPPORT	x3
12 - BOTTOM DRAWER FRONT	x1
13 - CENTRE DRAWER FRONT	x1
14 - TOP DRAWER FRONT	x1

HARDWARE REQUIRED

A		06
B		09
C		09

TOOLS REQUIRED

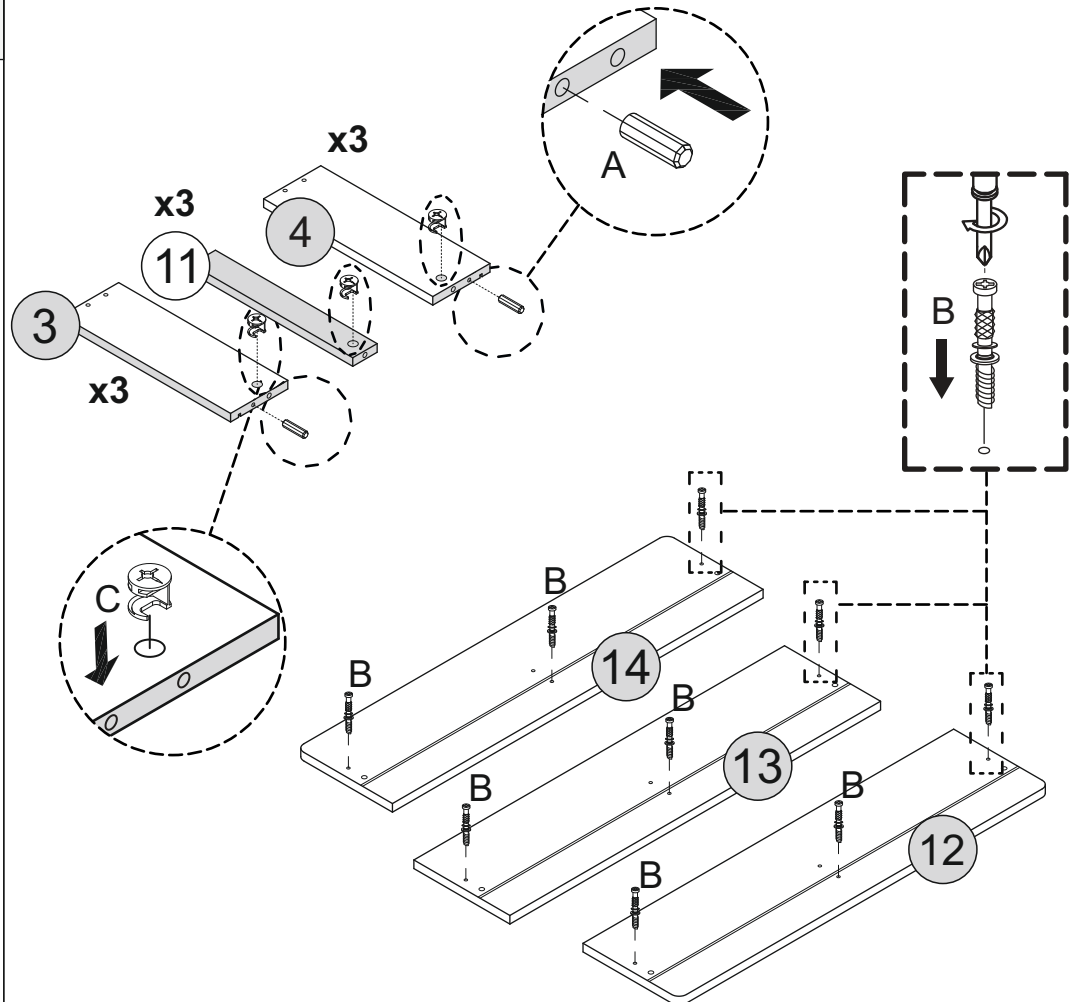
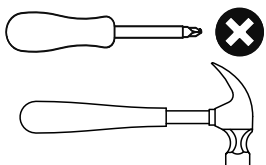

STEP 11

PARTS REQUIRED

- 3 - LEFT DRAWER SIDE x3
- 4 - RIGHT DRAWER SIDE x3
- 7 - DRAWER BACK x3
- 11 - DRAWER SUPPORT x3
- 17 - DRAWER BASE x3

HARDWARE REQUIRED

- Q  15

TOOLS REQUIRED

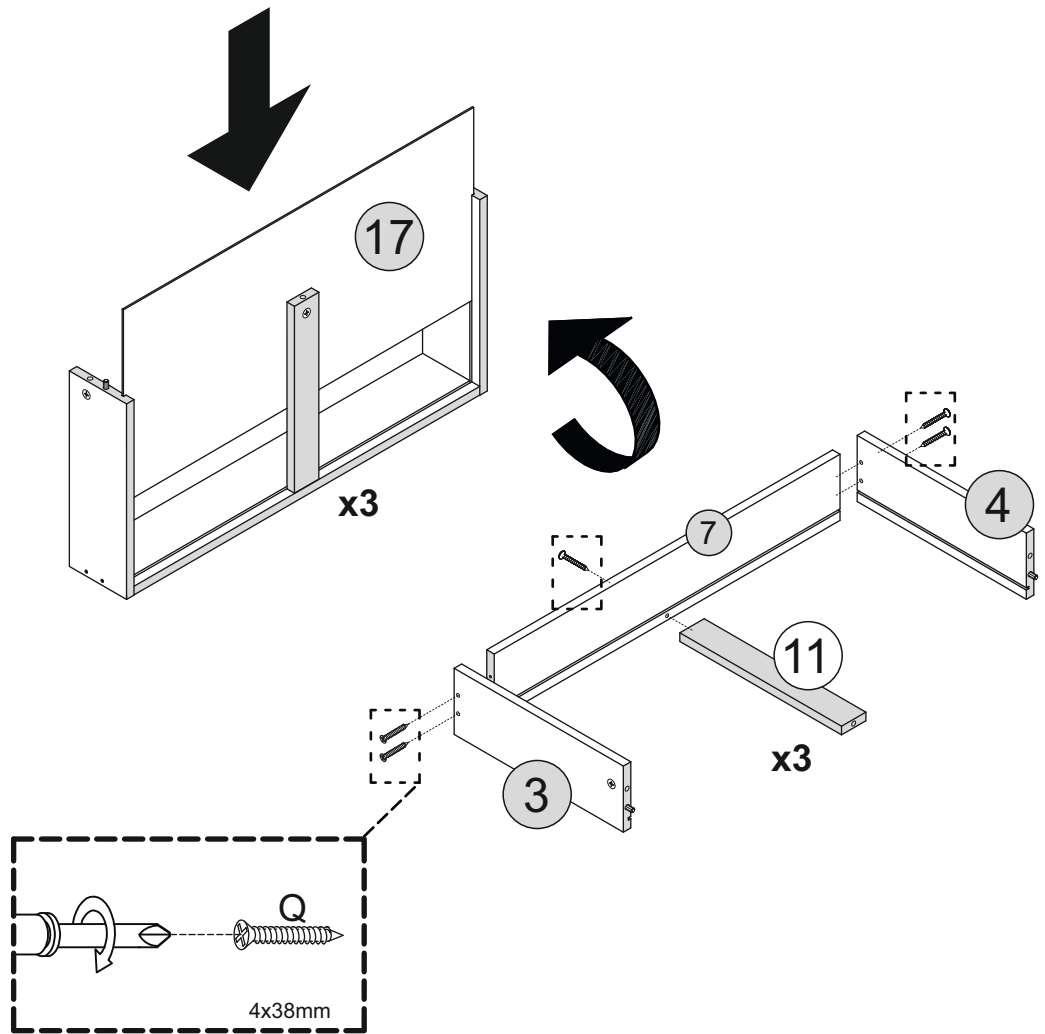
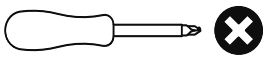

STEP 12

PARTS REQUIRED

- 12 - BOTTOM DRAWER FRONT x1
- 13 - CENTRE DRAWER FRONT x1
- 14 - TOP DRAWER FRONT x1

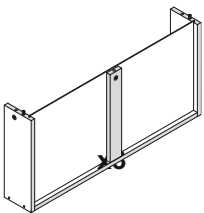

HARDWARE REQUIRED

TOOLS REQUIRED

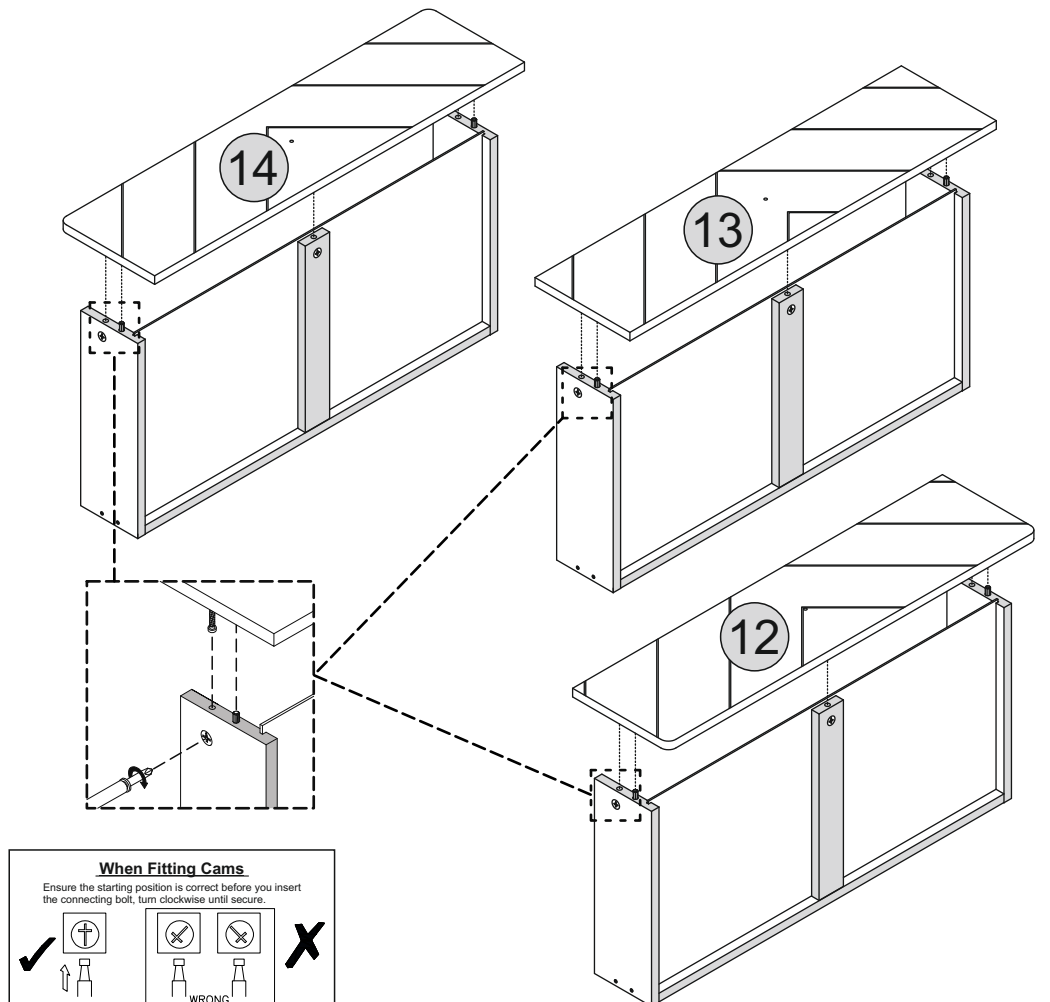
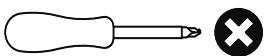

STEP 13

PARTS REQUIRED

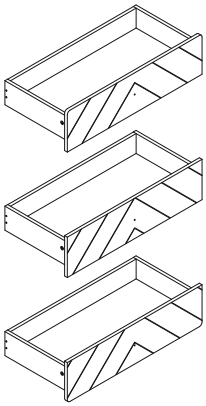

HARDWARE REQUIRED



TOOLS REQUIRED

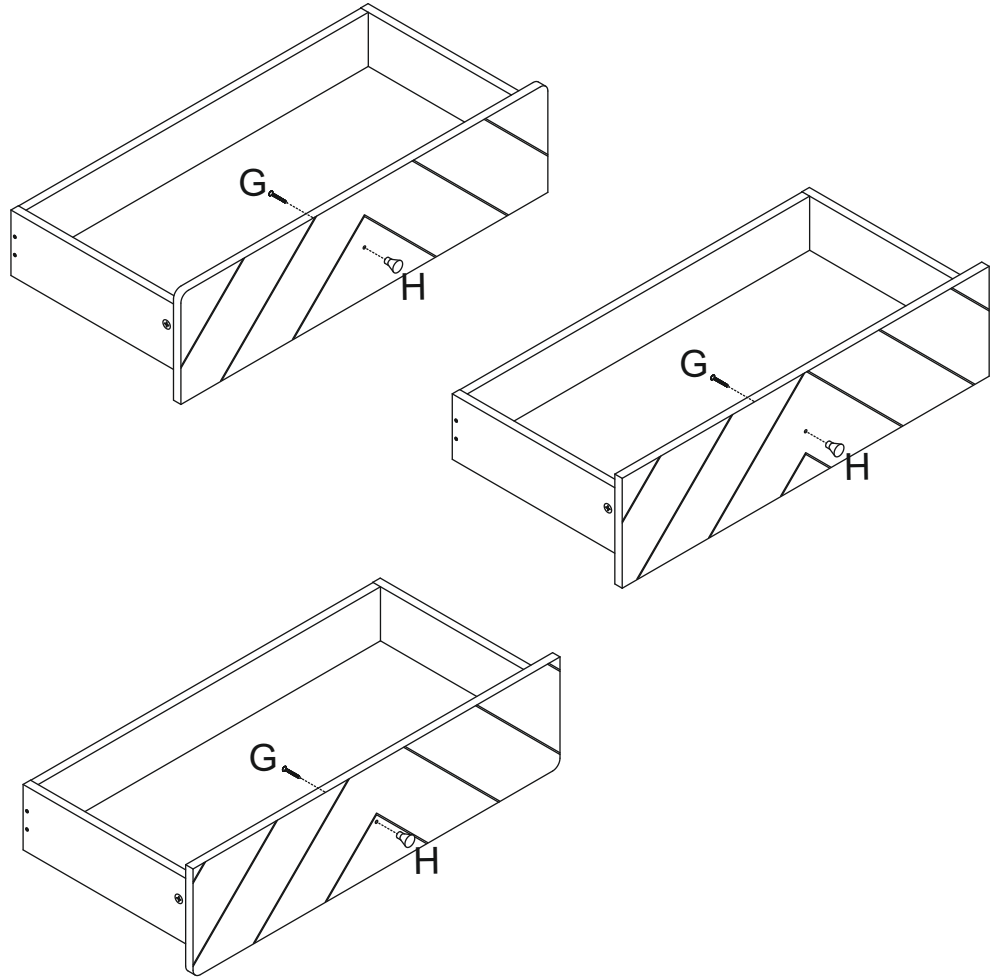
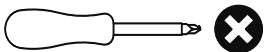

STEP 14

PARTS REQUIRED

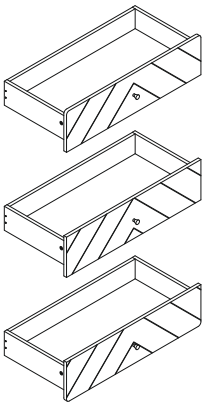

HARDWARE REQUIRED

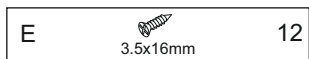

TOOLS REQUIRED

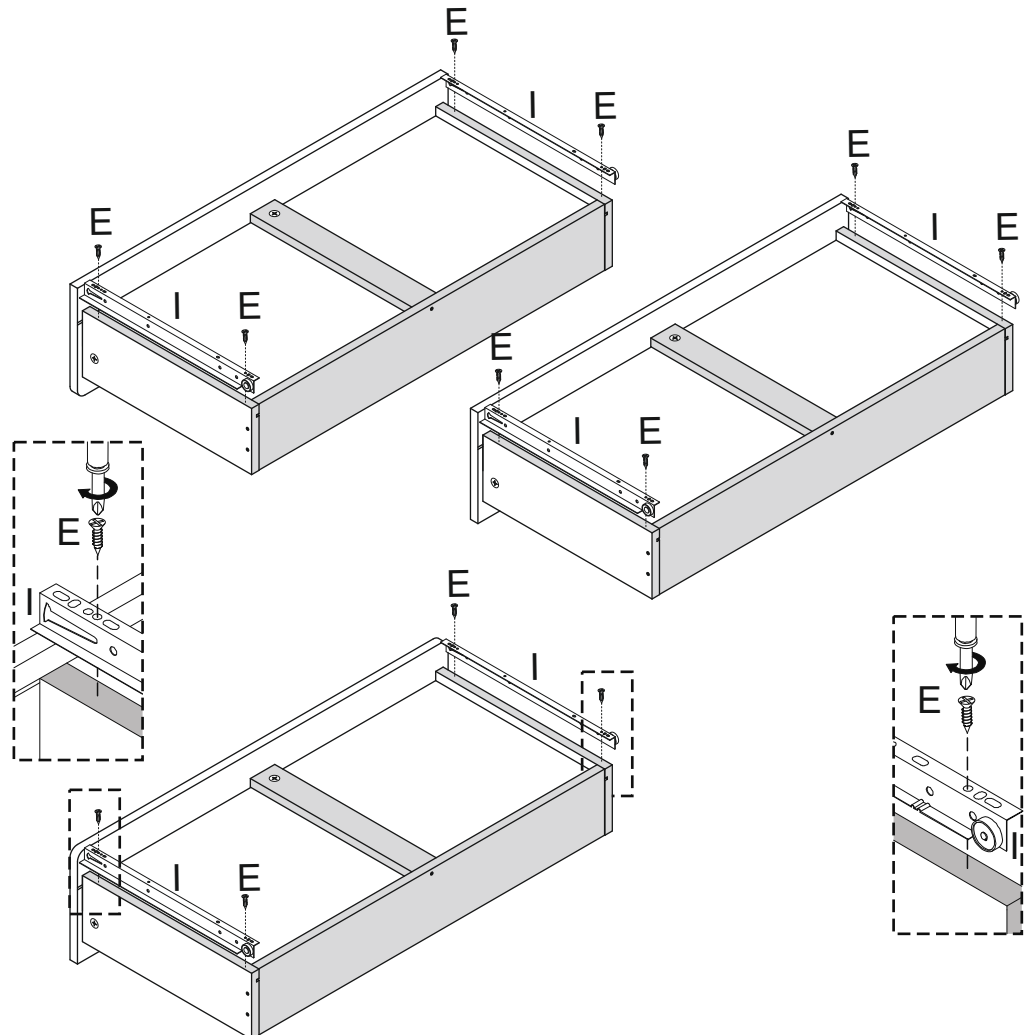
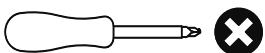

STEP 15

PARTS REQUIRED

15 - RIGHT SUPPORT PANEL x1

16 - LEFT SUPPORT PANEL x1

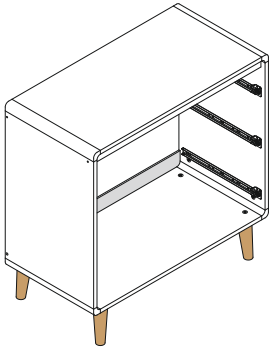

HARDWARE REQUIRED

Q  06

TOOLS REQUIRED

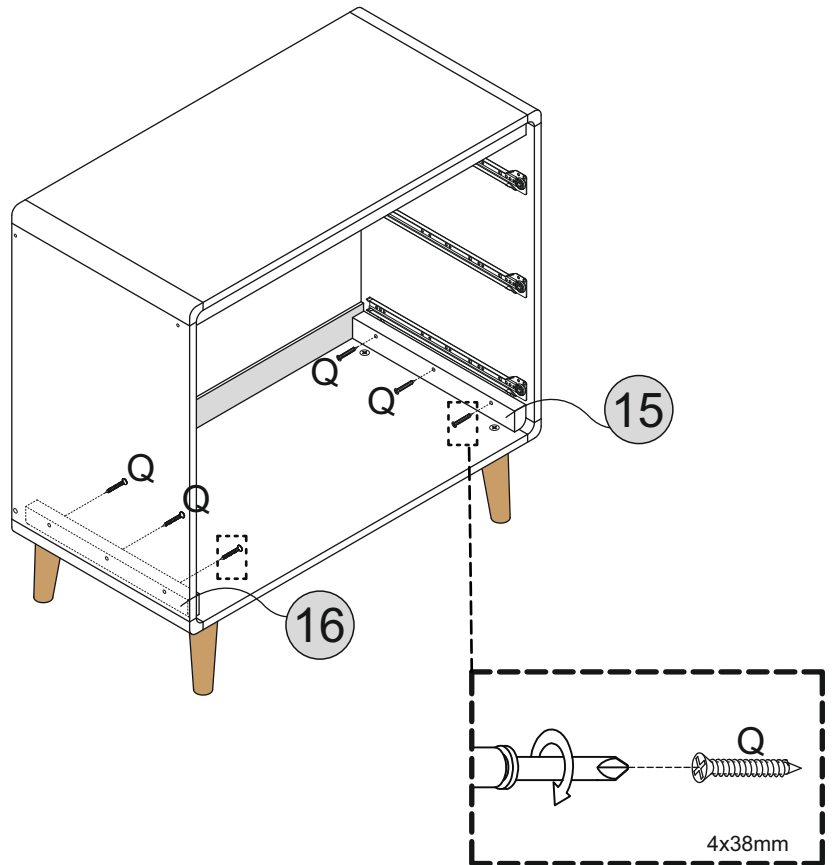
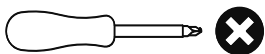

STEP 16

PARTS REQUIRED

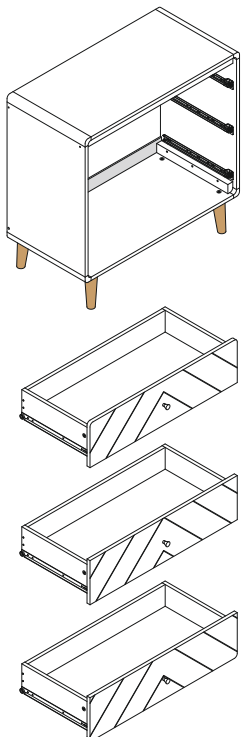

HARDWARE REQUIRED

TOOLS REQUIRED

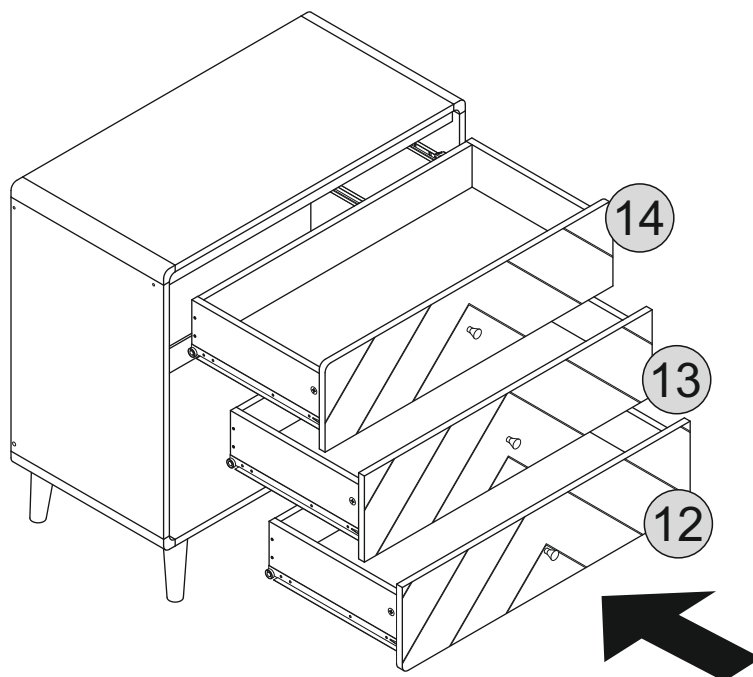

STEP 17

PARTS REQUIRED

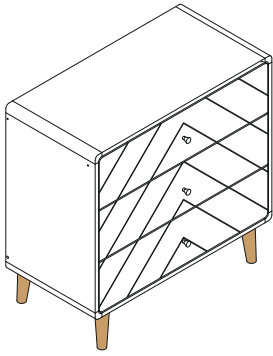

HARDWARE REQUIRED



TOOLS REQUIRED

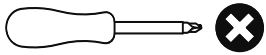

WARNING

Serious or fatal injuries can occur from furniture tipping over. To prevent the furniture from tipping over we recommend that it is permanently fixed to the wall.

Wall fixings are not supplied with this product as different wall materials require different types of fixing devices. Please make sure you use fixings suitable for the walls in your home.

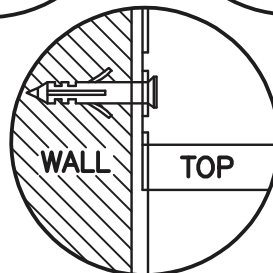
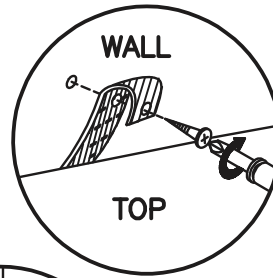
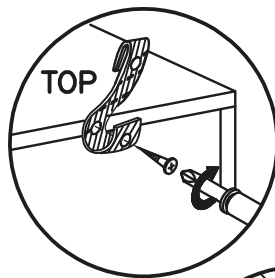
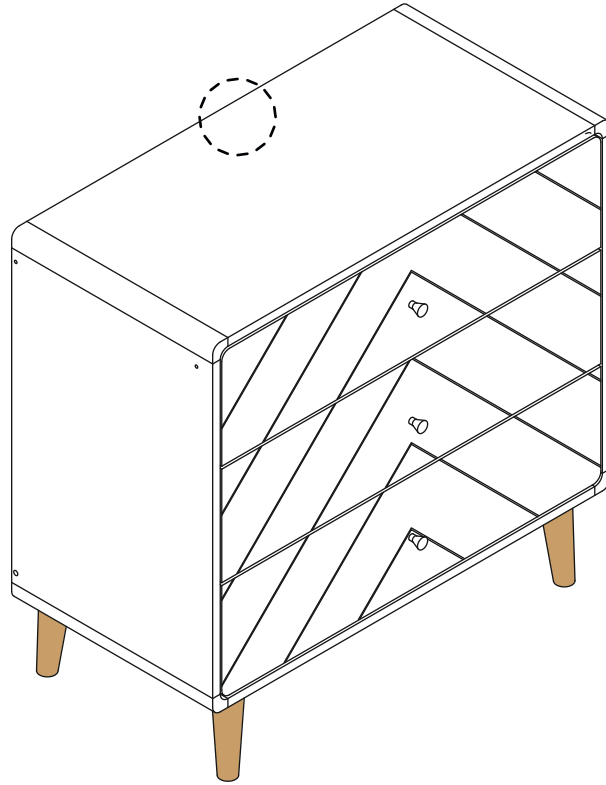

DIXIE 2 DRAWER BEDSIDE ASSEMBLY INSTRUCTIONS

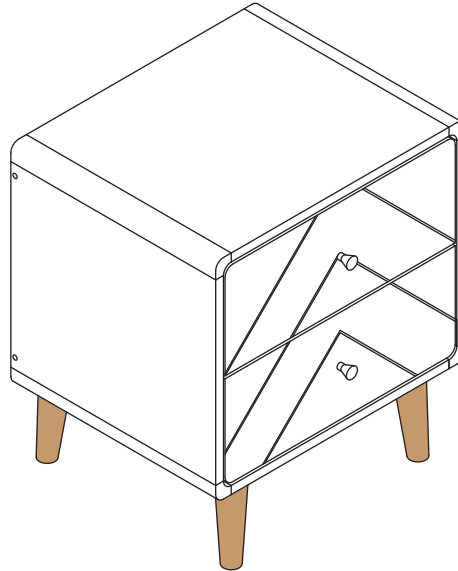

FOR DOMESTIC USE ONLY IMPORTANT

PLEASE READ BEFORE YOU CONTINUE FURTHER

THE PRODUCT YOU HAVE PURCHASED WILL GIVE YOU MANY YEARS OF SERVICE IF YOU FOLLOW THE GUIDELINES FOR ITS SAFE ASSEMBLY AND PERIODIC MAINTENANCE AND CLEANING.

ASSEMBLE ON A SOFT CLEAN SURFACE.

DO NOT USE ANY TOOLS OTHER THAN THOSE SHOWN.

ANY SPANNERS OR ALLEN KEYS REQUIRED ARE INCLUDED WITH THE FITTING KIT.

DO NOT FOR ANY REASON USE A POWER TOOL TO ASSEMBLE THIS PRODUCT. ITS USE WILL INVALIDATE ANY CLAIM YOU MAY HAVE AND COULD MAKE THIS PRODUCT UNSAFE.

DEPENDING ON THE AMOUNT OF USE THIS PRODUCT RECEIVES, IT MAY BE NECESSARY TO TIGHTEN UP THE FIXINGS FROM TIME TO TIME. THIS IS COMPLETELY NORMAL FOR ANY FLAT PACK FURNITURE. DO NOT OVERTIGHTEN FIXINGS.

FOR CLEANING, YOU MAY USE A DAMP CLOTH (NOT WET). DO NOT USE POLISH, DETERGENT OR CHEMICAL CLEANERS.



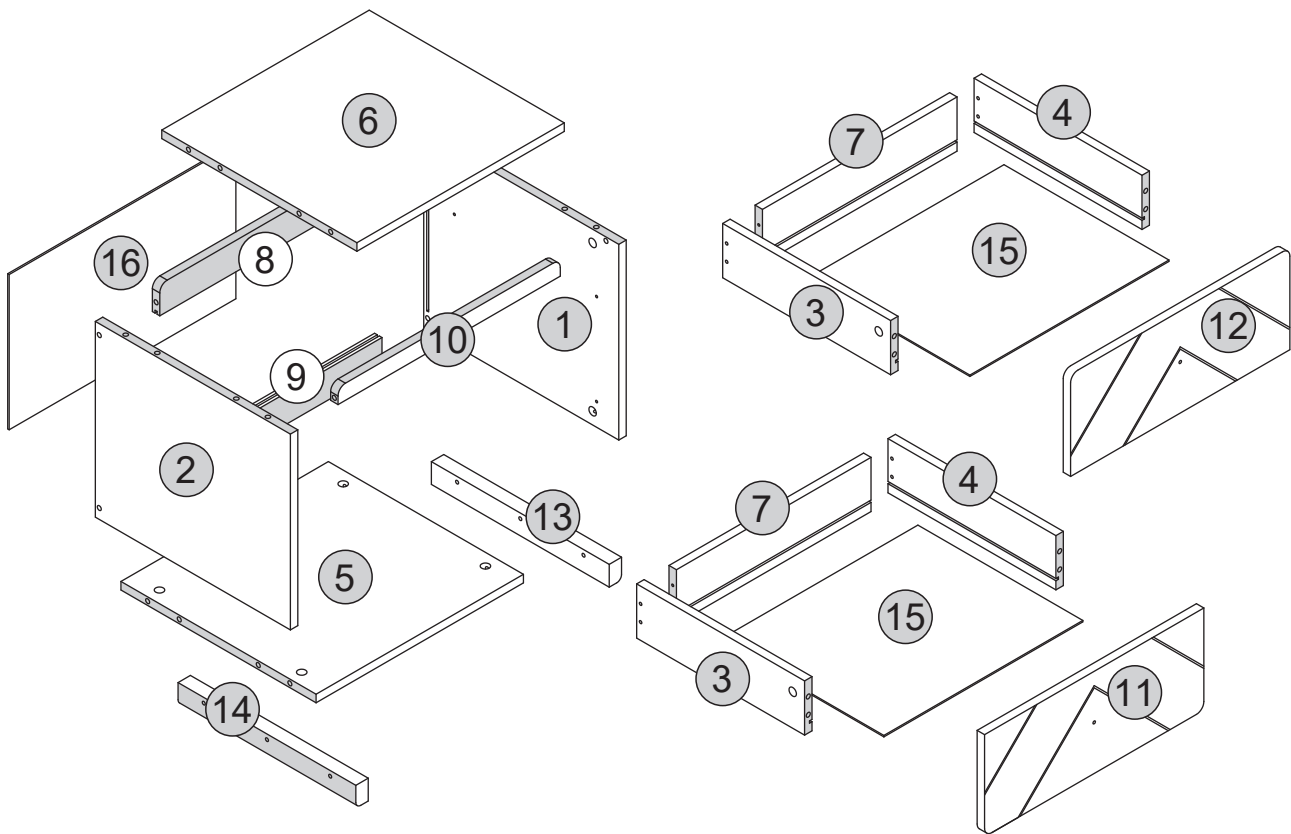













THIS SURFACE OF THIS ITEM IS NOT HEAT RESISTANT. ALWAYS USE A PLACE MAT UNDER HOT OR COLD ITEMS TO PREVENT MARKING.



PART LIST

Part Number	Part Code	Part Description	Quantity	Carton
1	S100-103-087-ZF1-01	Right Side Panel	1	1/1
2	S100-103-087-ZF1-02	Left Side Panel	1	1/1
3	S100-103-087-ZF1-03	Left Drawer Side Panel	2	1/1
4	S100-103-087-ZF1-04	Right Drawer Side Panel	2	1/1
5	S100-103-087-ZF1-05	Bottom Panel	1	1/1
6	S100-103-087-ZF1-06	Top Panel	1	1/1
7	S100-103-087-ZF1-07	Drawer Back Panel	2	1/1
8	S100-103-087-ZF1-08	Top Back Support Panel	1	1/1
9	S100-103-087-ZF1-09	Bottom Back Support Panel	1	1/1
10	S100-103-087-ZF1-10	Front Support Panel	1	1/1
11	S100-103-087-ZF1-11	Bottom Drawer Front	1	1/1
12	S100-103-087-ZF1-12	Top Drawer Front	1	1/1
13	S100-103-087-ZF1-13	Right Support Panel	1	1/1
14	S100-103-087-ZF1-14	Left Support Panel	1	1/1
15	S100-103-087-ZF1-15	Drawer Base	2	1/1
16	S100-103-087-ZF1-16	Back Panel	1	1/1

HARDWARE LIST

No	Part Name		Qty	Carton
A	M8x30mm Wooden Dowel		x22	1
B	Minifix Cam Bolt <small>(8032t)</small>		x20	1
C	Minifix Cam Nut <small>(1512)</small>		x20	1
D	M6.3x40mm Unitar Screw		x4	1
E	M3.5x16mm Screw		x18	1
F	M4x20mm Screw		x20	1
G	M4x25mm Screw		x2	1
H	Handle		x2	1
I	14" Drawer Slide <small>(VKT 0.9 - W)</small>		x2	1
J	PVC L-Bracket		x1	1
K	Screw Cover <small>(Sticker 22mm)</small>		x4	1
L	PVC Leg 160mm		x4	1
M	Corner Support <small>(AC101)</small>		x2	1
N	Allen Key M4		x1	1
O	Jointing Panel <small>(396x30x30mm)</small>		x4	1
P	Wall Fixing <small>(4x20mm=1pc)</small>		x1	1
Q	M4x38mm Screw		x14	1

TIPS FOR FITTINGS CAM-LOCKS

WHEN FITTING CAM NUT. ENSURE STARTING POSITION IS CORRECT BEFORE YOU INSERT CONNECTING CAM BOLT TURN CLOCKWISE UNTIL SECURE

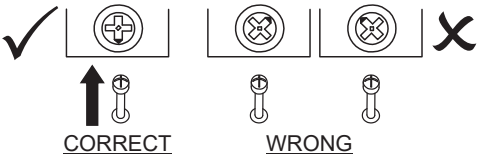

CORRECT
WRONG

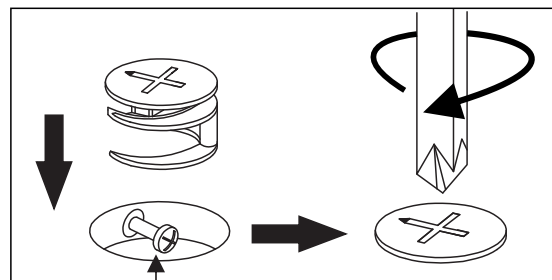

Cam bolt head needs to be in centre

CAMBOLT

Tighten until shoulder in flush with panel. Do not overtighten or undertighten (see example below)

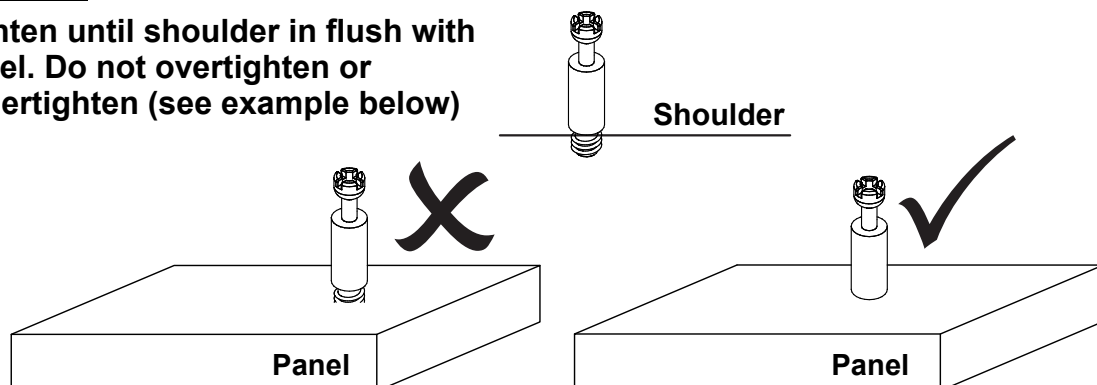

STEP 1

PARTS REQUIRED

6 - TOP PANEL x1

10 - FRONT SUPPORT PANEL x1

HARDWARE REQUIRED

A  18

B  16

C  04

E  3.5x16mm 01

J  01

O  04

TOOLS REQUIRED

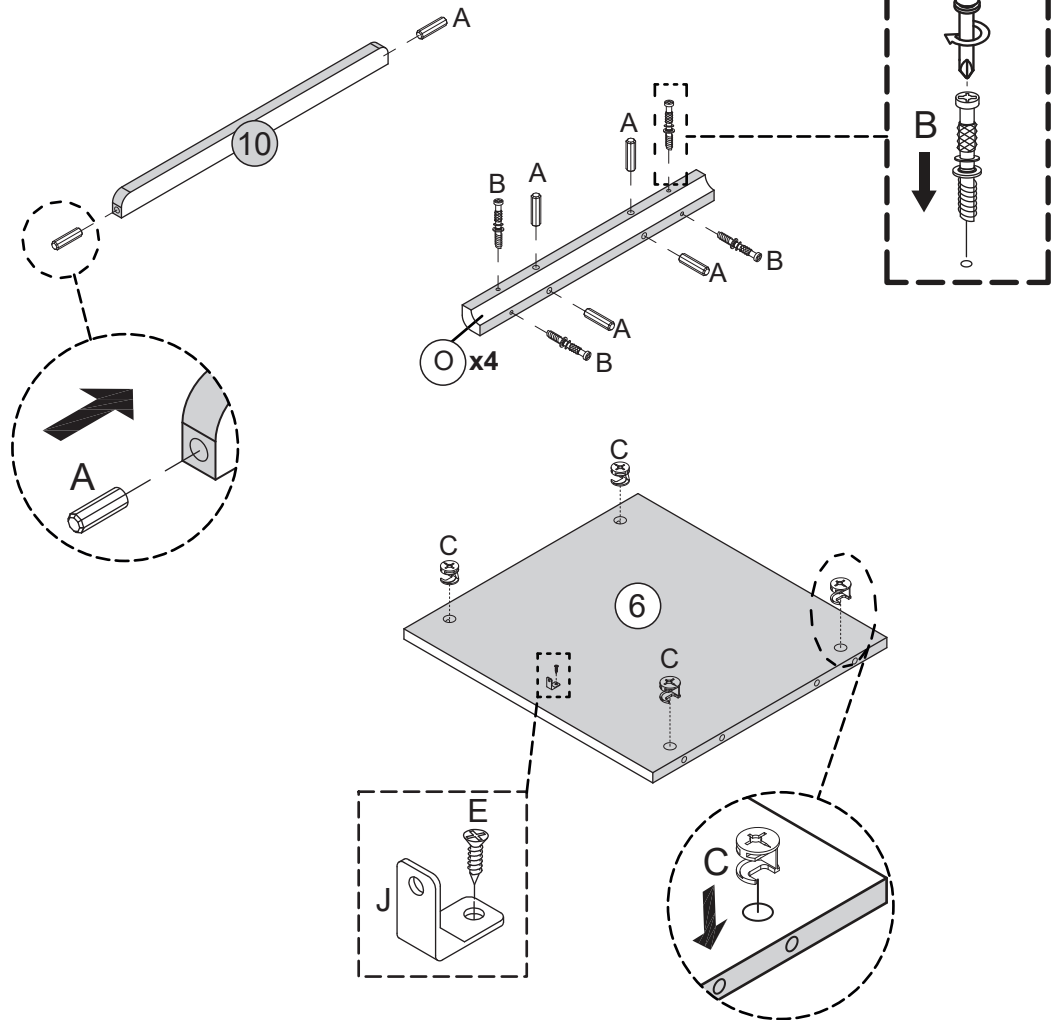
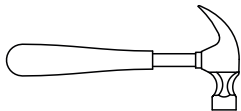
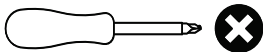

STEP 2

PARTS REQUIRED

1 - RIGHT SIDE PANEL x1

2 - LEFT SIDE PANEL x1

5 - BOTTOM PANEL x1

HARDWARE REQUIRED

C  12

E  3.5x16mm 08

I  02

TOOLS REQUIRED

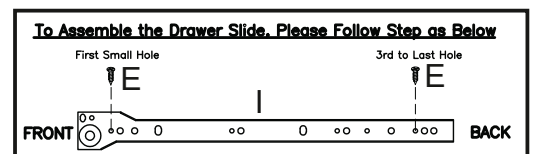
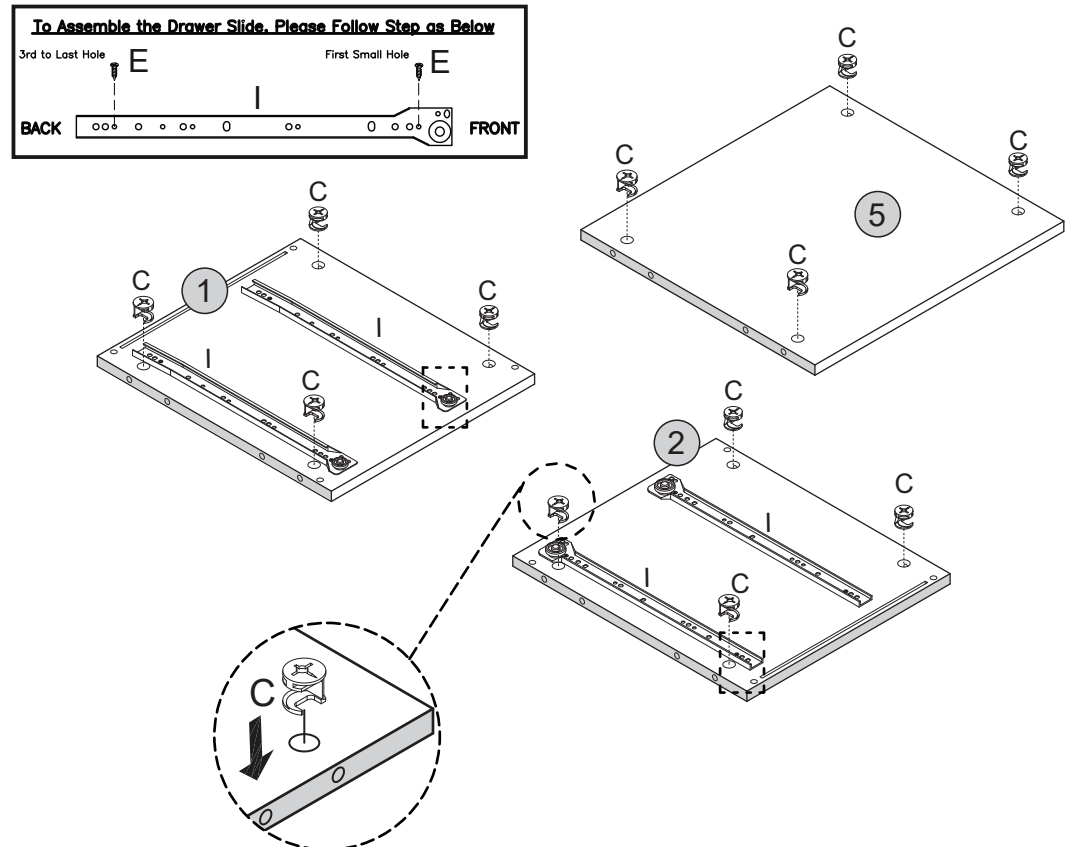
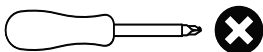

STEP 3

PARTS REQUIRED

1 - RIGHT SIDE PANEL x1

2 - LEFT SIDE PANEL x1

HARDWARE REQUIRED

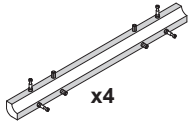

TOOLS REQUIRED

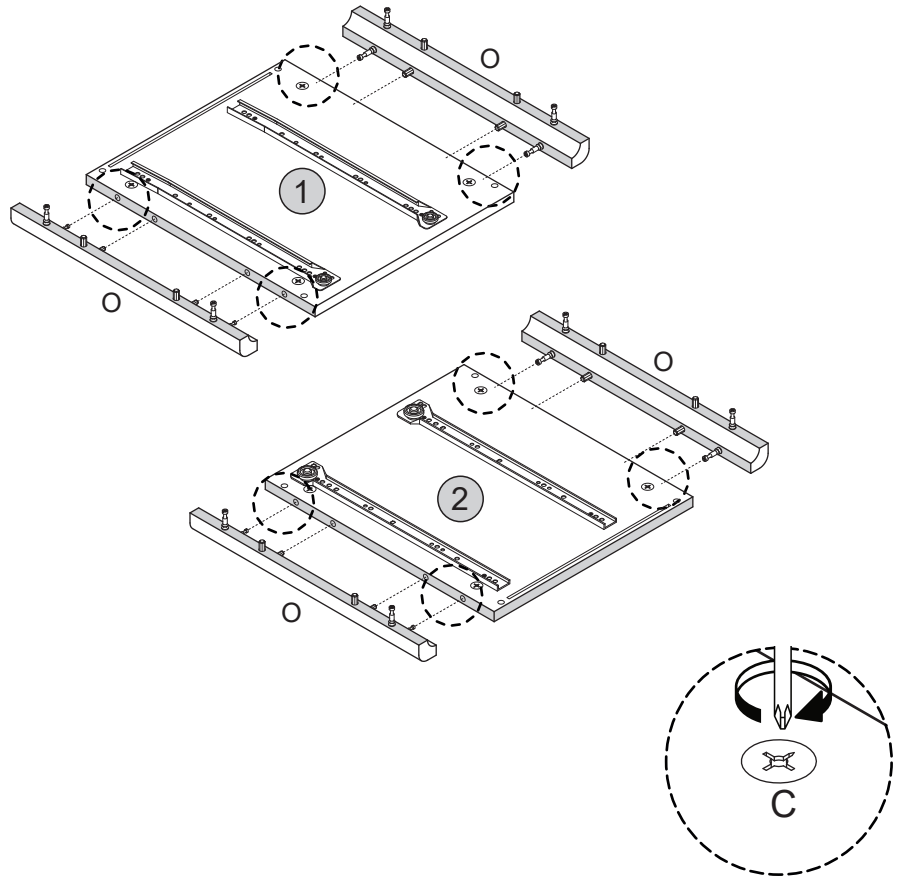
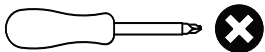

STEP 4

PARTS REQUIRED

8 - TOP BACK SUPPORT x1

9 - BOTTOM BACK SUPPORT x1

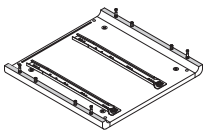

HARDWARE REQUIRED

D  02

K  02

TOOLS REQUIRED

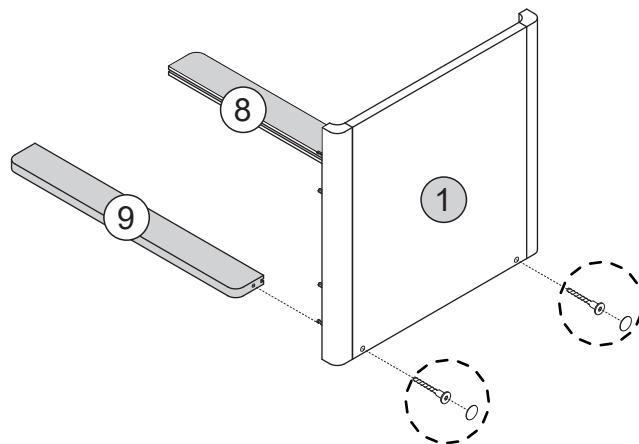
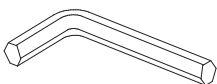

STEP 1

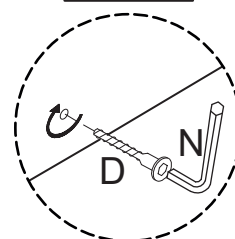

STEP 2

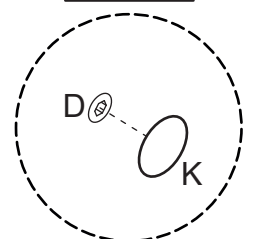

STEP 5

PARTS REQUIRED

5 - BOTTOM PANEL x1

6 - TOP PANEL x1

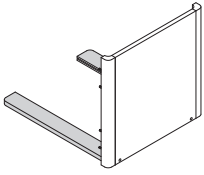

HARDWARE REQUIRED

TOOLS REQUIRED

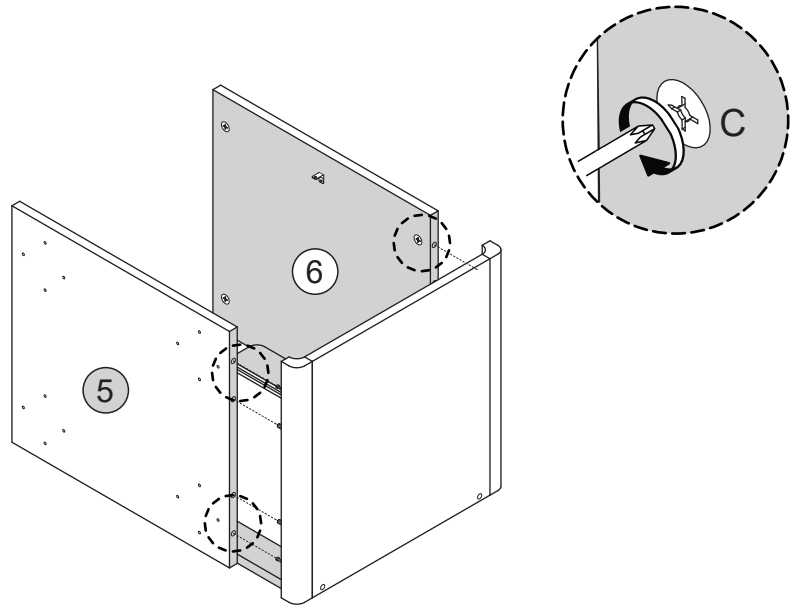
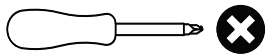

STEP 6

PARTS REQUIRED

10 - FRONT SUPPORT PANEL x1

16 - BACK PANEL x1

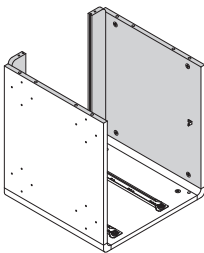

HARDWARE REQUIRED

TOOLS REQUIRED

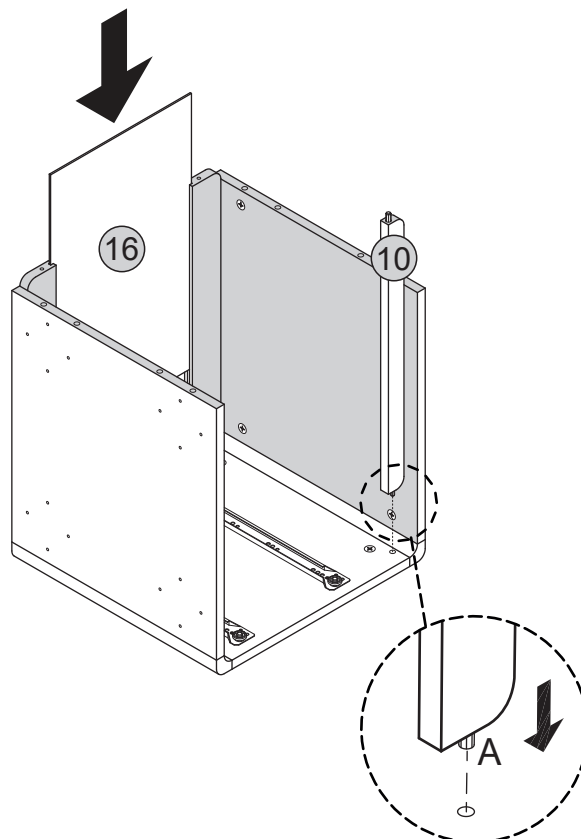
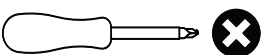

STEP 7

PARTS REQUIRED

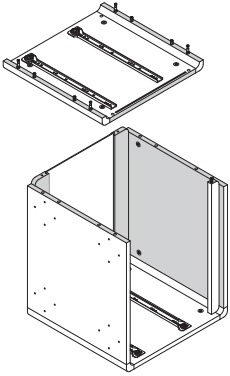

HARDWARE REQUIRED

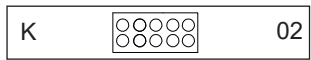
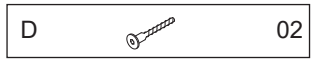

TOOLS REQUIRED

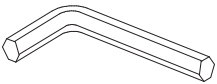

STEP 1

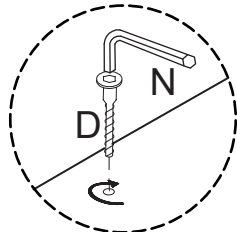

STEP 2

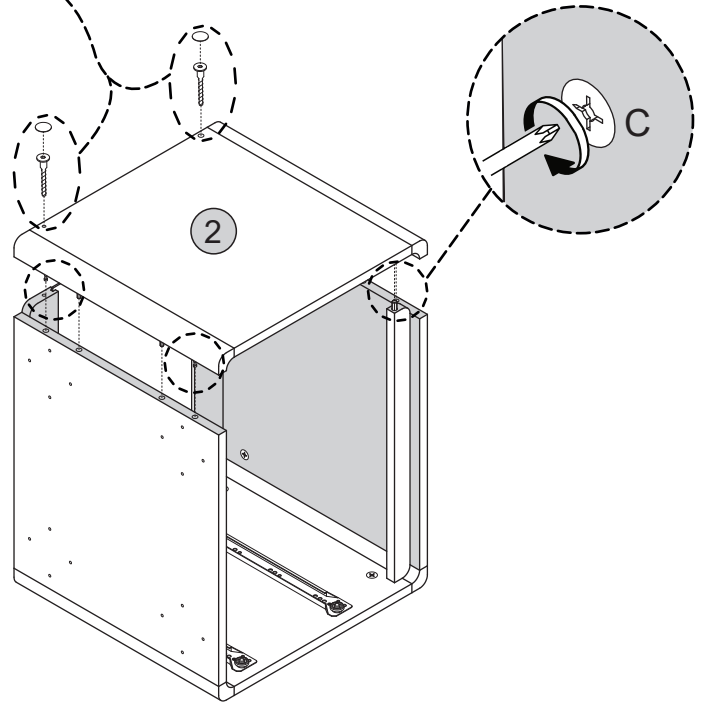
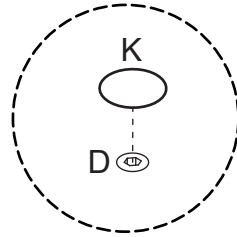

STEP 8

PARTS REQUIRED

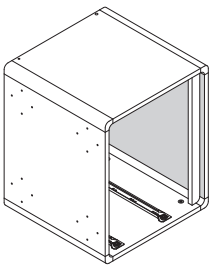

HARDWARE REQUIRED



TOOLS REQUIRED

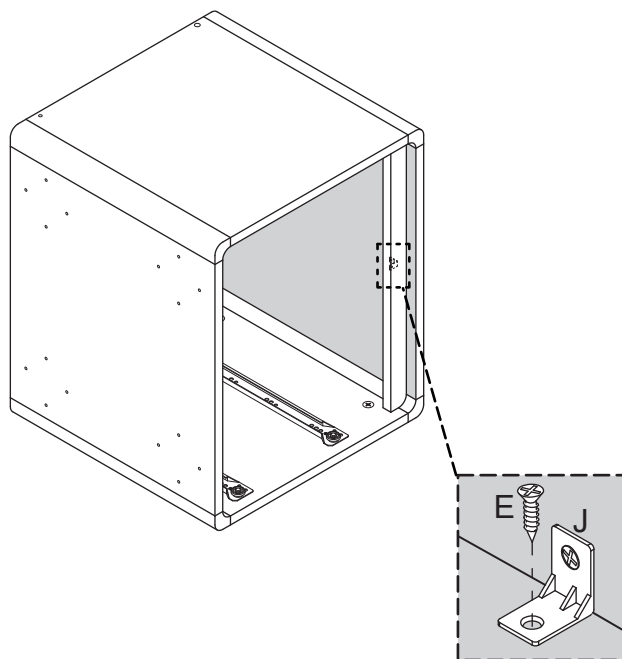
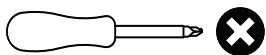

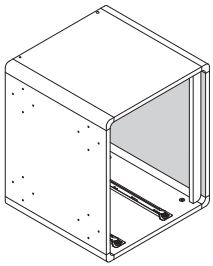

STEP 9

PARTS REQUIRED



HARDWARE REQUIRED

F	 4x20mm	20
L		04
M		02

TOOLS REQUIRED

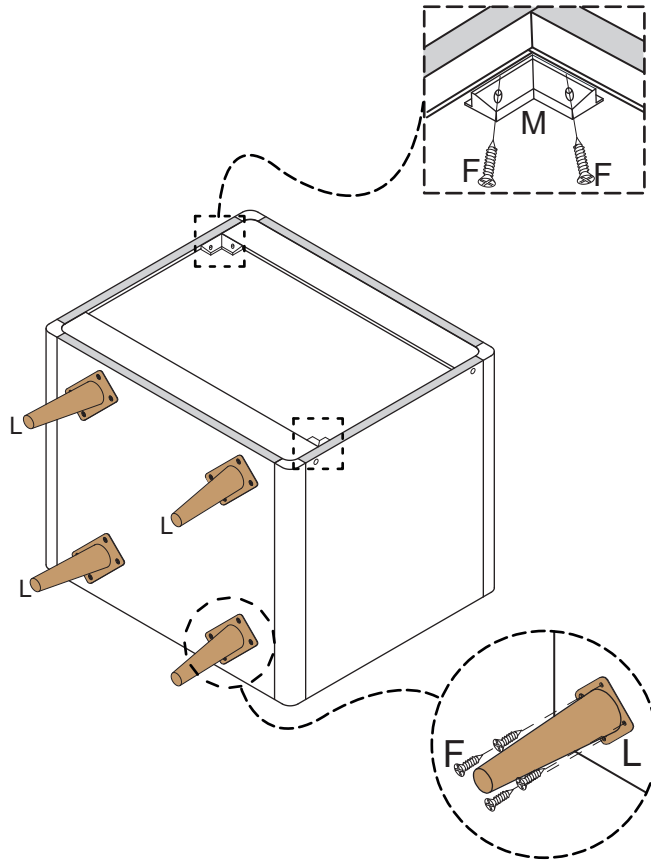
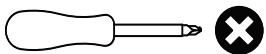



STEP 10

PARTS REQUIRED

3 - LEFT DRAWER SIDE	x2
4 - RIGHT DRAWER SIDE	x2
11 - BOTTOM DRAWER FRONT	x1
12 - TOP DRAWER FRONT	x1

HARDWARE REQUIRED

A		04
B		04
C		04

TOOLS REQUIRED

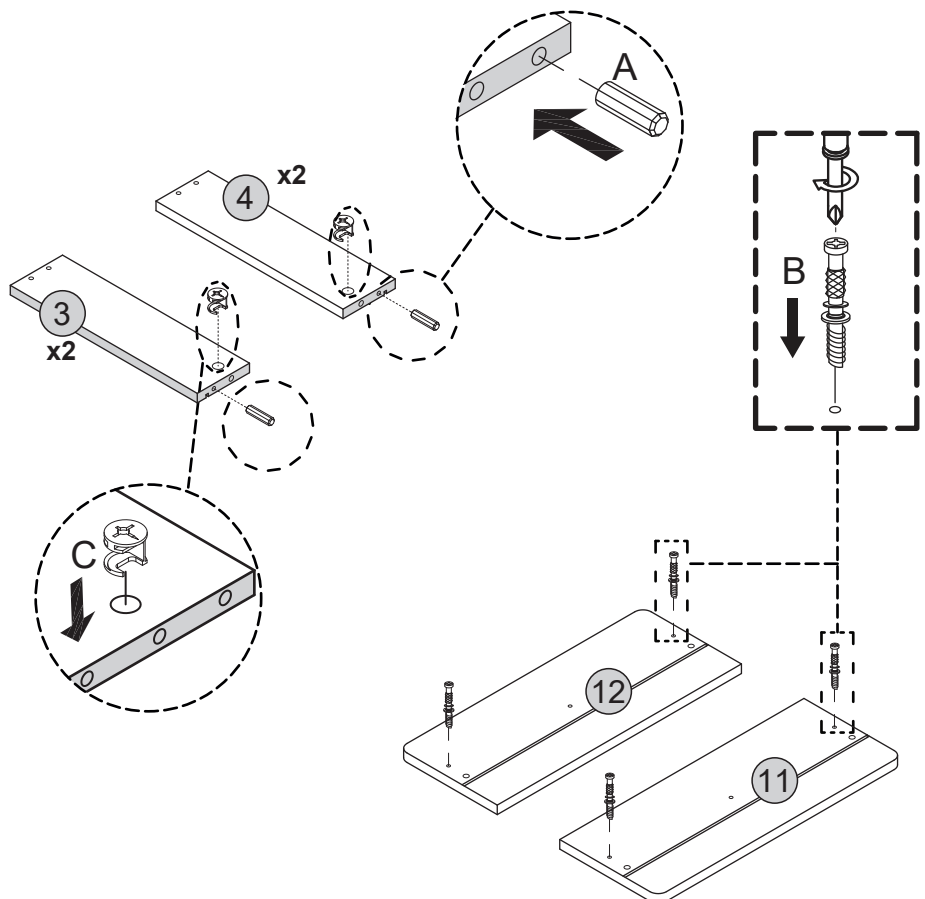
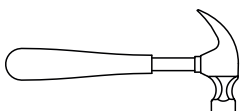
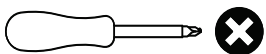

STEP 11

PARTS REQUIRED

- 3 - LEFT DRAWER SIDE x2
- 4 - RIGHT DRAWER SIDE x2
- 7 - DRAWER BACK x2
- 15 - DRAWER BASE x2

HARDWARE REQUIRED

- Q  08

TOOLS REQUIRED

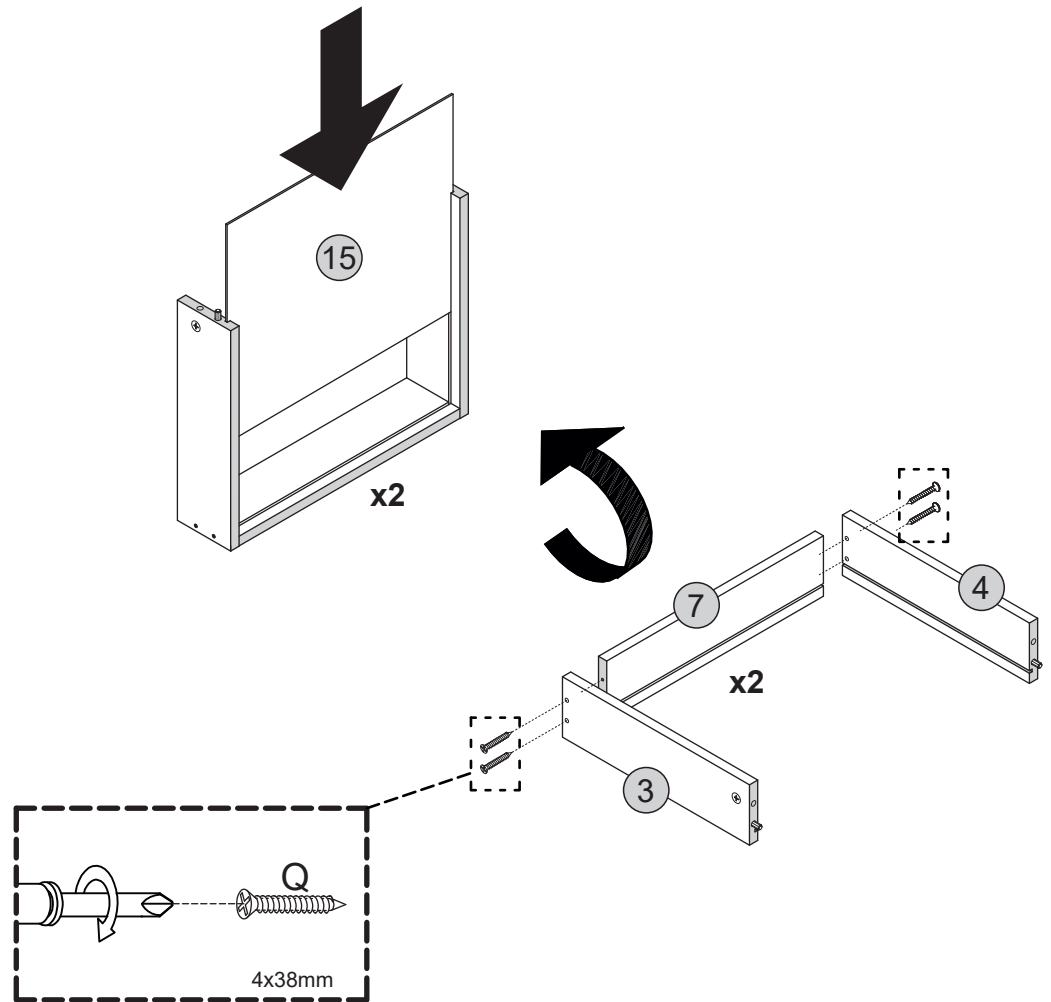
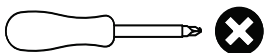

STEP 12

PARTS REQUIRED

- 11 - BOTTOM DRAWER FRONT x1
- 12 - TOP DRAWER FRONT x1

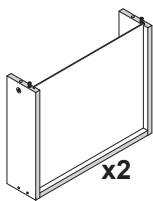

HARDWARE REQUIRED

TOOLS REQUIRED

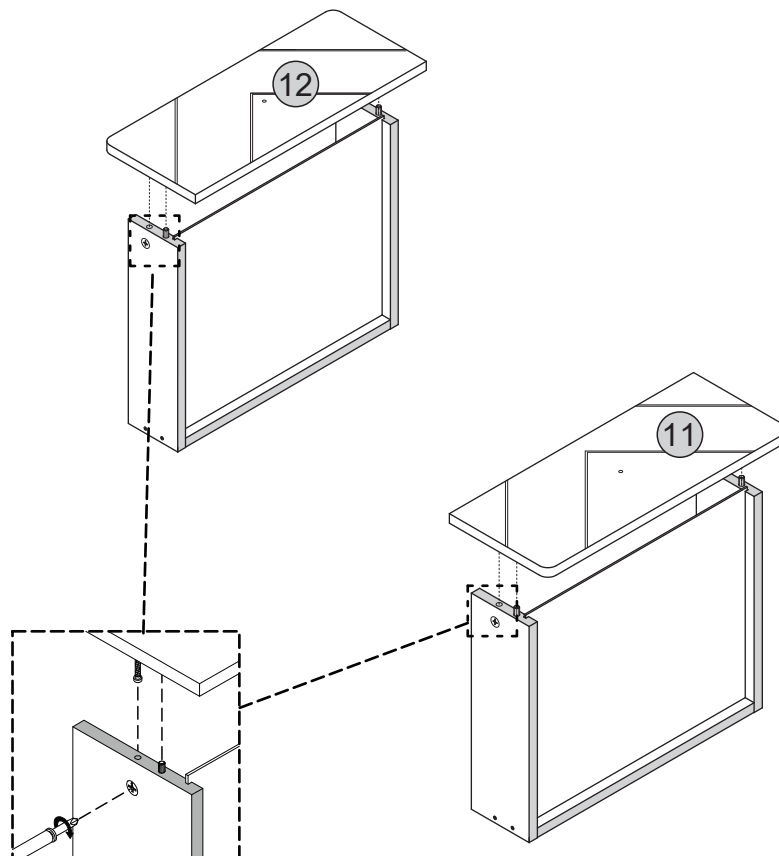
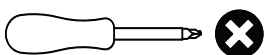

STEP 13

PARTS REQUIRED

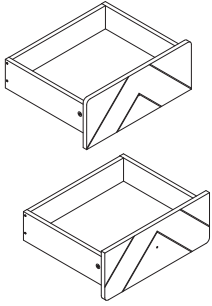

HARDWARE REQUIRED



TOOLS REQUIRED

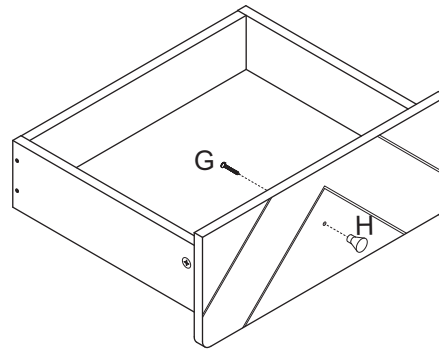
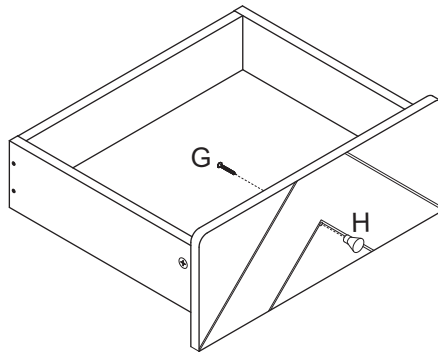
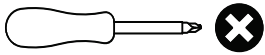

STEP 14

PARTS REQUIRED

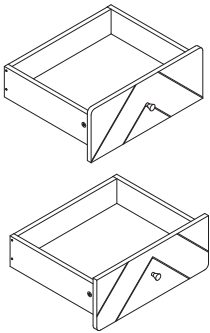

HARDWARE REQUIRED



TOOLS REQUIRED

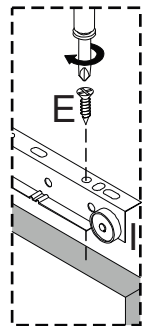
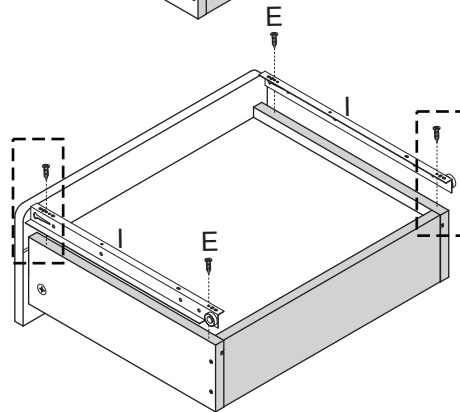
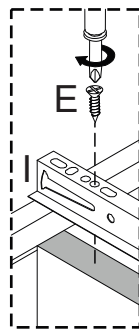
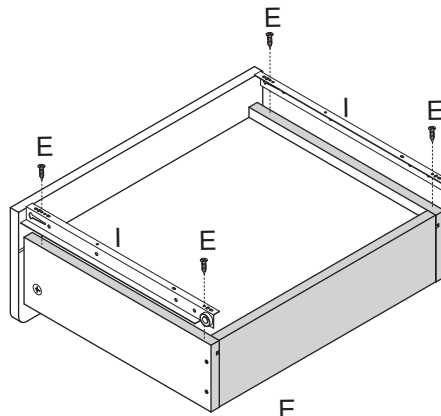
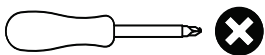

STEP 15

PARTS REQUIRED

13 - RIGHT SUPPORT PANEL x1

14 - LEFT SUPPORT PANEL x1

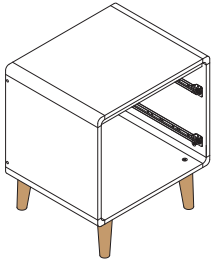

HARDWARE REQUIRED

Q  06

TOOLS REQUIRED

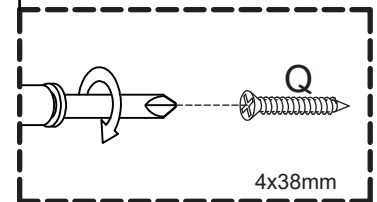
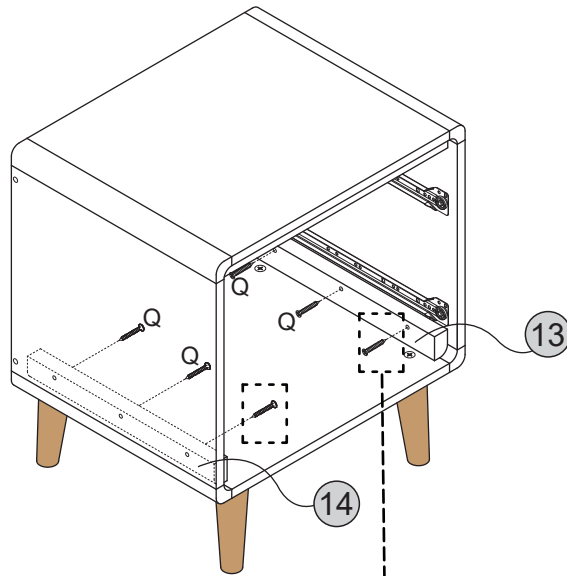
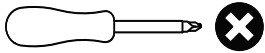

STEP 16

PARTS REQUIRED

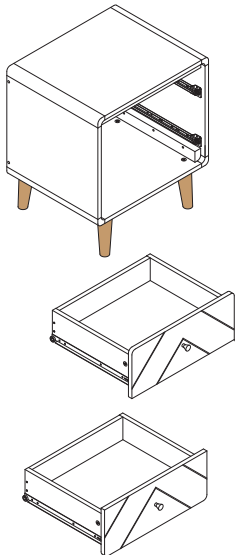

HARDWARE REQUIRED

TOOLS REQUIRED

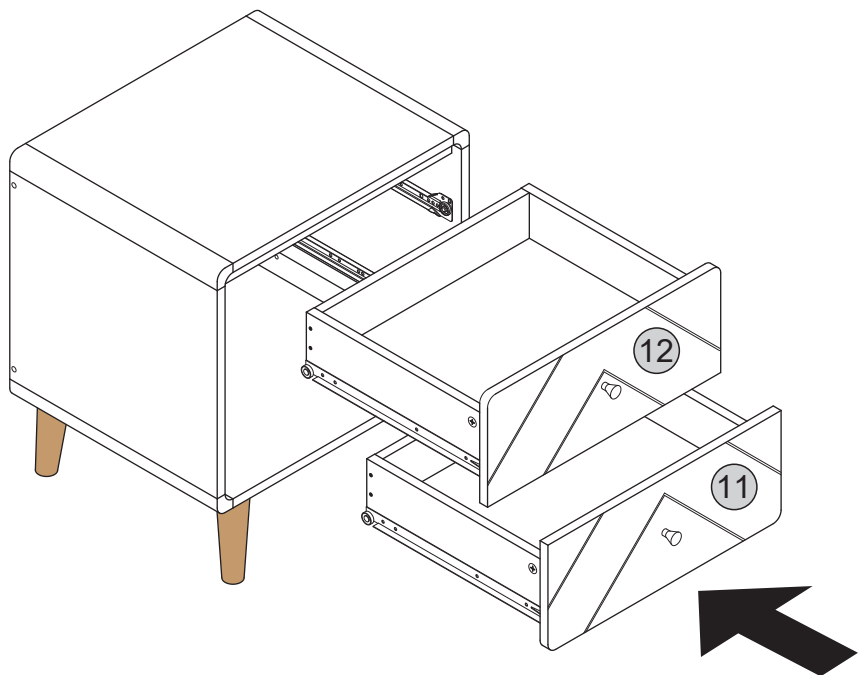

STEP 17

PARTS REQUIRED

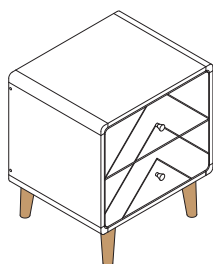

HARDWARE REQUIRED

P  01

TOOLS REQUIRED

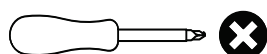

WARNING

Serious or fatal injuries can occur from furniture tipping over. To prevent the furniture from tipping over we recommend that it is permanently fixed to the wall.

Wall fixings are not supplied with this product as different wall materials require different types of fixing devices. Please make sure you use fixings suitable for the walls in your home.

