

55652

# PANAMA 2 DOOR 2 DRAWER SIDEBOARD ASSEMBLY INSTRUCTIONS

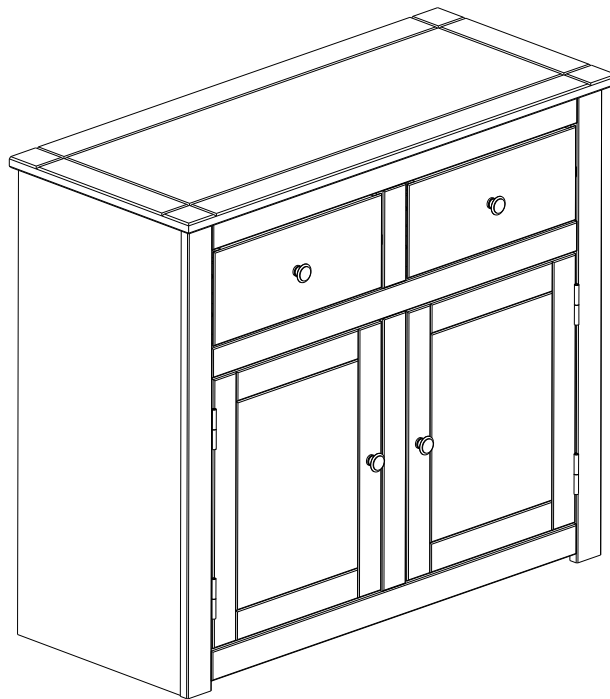

## **IMPORTANT** PLEASE READ BEFORE YOU CONTINUE FURTHER **FOR DOMESTIC USE ONLY** **CARE AND MAINTENANCE**

After unpacking this product please keep the original packaging in case it needs to be returned for any reason.

- Please ensure all fittings and parts are present before commencing with assembly.
- We recommend that you lay a blanket or sheet on the floor to avoid damage to both your floor and the product.
- We strongly recommend that you keep children away from your work area.
- Assemble this product as close to its final position as possible.
- Never drag or push products as this could cause damage to the joints making it inferior.
- Do not place this product next to a radiator or in direct sunlight.
- Wood is a natural product and may expand if subjected to damp and may shrink or crack if subjected to heat. Therefore it is recommended that room temperature is maintained, with no sudden temperature fluctuations.
- Make sure any spillage is wiped off immediately.
- Do not place hot or chilled items directly on to the surface, use a place mat or marking will occur.
- For general cleaning use a duster, and do not use detergents of any kind. However, the surface will need to be retreated from time to time. This can be done by using block wax (unperfumed) and rubbing it over the whole item.
- From time to time it may be necessary to tighten fittings, regular inspections should be carried out.

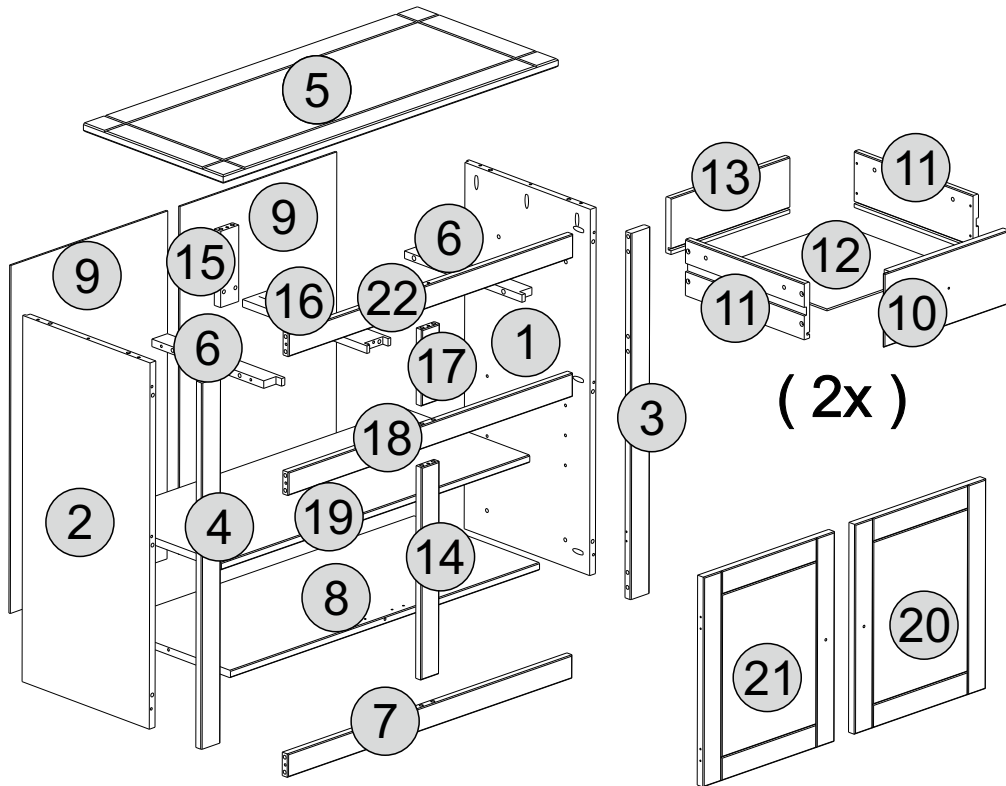









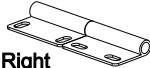

\* Use of power tools to assemble this product will invalidate any claim and damage this product making it unsafe !!!  
\* Please assemble on a clean soft surface to avoid damage.

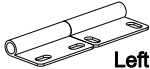
\* Please check contents and read the instructions before commencing assembly.  
\* Assemble this product following the enclosed instructions carefully.  
\* Please take care to avoid damaging panels during assembly.

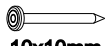
## PARTS LIST

Part Number	Part Code	Part Description	Quantity	Carton
1	S400-405-013-PJ1-01	Right Side Panel	1	1/1
2	S400-405-013-PJ1-02	Left Side Panel	1	1/1
3	S400-405-013-PJ1-03	Right Front Upright	1	1/1
4	S400-405-013-PJ1-04	Left Font Upright	1	1/1
5	S400-405-013-PJ1-05	Top Panel	1	1/1
6	S400-405-013-PJ1-06	Drawer Runner	2	1/1
7	S400-405-013-PJ1-07	Botom Front Crossbeam	1	1/1
8	S400-405-013-PJ1-08	Base	1	1/1
9	S400-405-013-PJ1-09	Back Panel	2	1/1
10	S400-405-013-PJ1-10	Drawer Front	2	1/1
11	S400-405-013-PJ1-11	Drawer Side	4	1/1
12	S400-405-013-PJ1-12	Drawer Bottom	2	1/1
13	S400-405-013-PJ1-13	Drawer Back	2	1/1
14	S400-405-013-PJ1-14	Centre Front Upright	1	1/1
15	S400-405-013-PJ1-15	Back Upright	1	1/1
16	S400-405-013-PJ1-16	Centre Drawer Runner	1	1/1
17	S400-405-013-PJ1-17	Centre Front Upright	1	1/1
18	S400-405-013-PJ1-18	Centre Front Crossbeam	1	1/1
19	S400-405-013-PJ1-19	Adjustable Shelf	1	1/1
20	S400-405-013-PJ1-20	Right Door	1	1/1
21	S400-405-013-PJ1-21	Left Door	1	1/1
22	S400-405-013-PJ1-22	Top Front Crossbeam	1	1/1

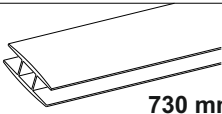
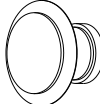
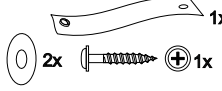
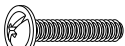
## FITTINGS

<b>A</b>	 Ø 8 x 30mm	<b>48</b>	<b>H</b>	 Right	<b>02</b>
<b>B</b>	 Ø 3,5 x 30mm	<b>37</b>	<b>I</b>	 Left	<b>02</b>
<b>C</b>	 Ø 3,0 x 30mm	<b>16</b>	<b>J</b>	 10x10mm	<b>26</b>
<b>D</b>	 Ø 3,0 x 14mm (Black)	<b>26</b>	<b>K</b>		<b>04</b>
<b>E</b>		<b>02</b>	<b>L</b>	 730 mm	<b>01</b>
<b>F</b>		<b>04</b>	<b>M</b>	 1x 2x 1x	<b>01</b>
<b>G</b>	 M4 x 25mm	<b>04</b>	<b>N</b>		<b>01</b>

## TOOLS REQUIRED

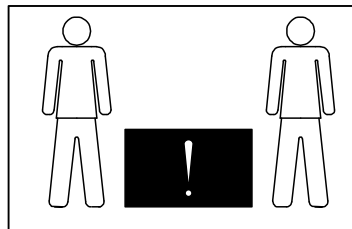
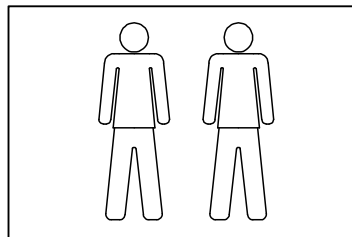
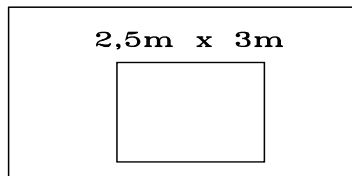
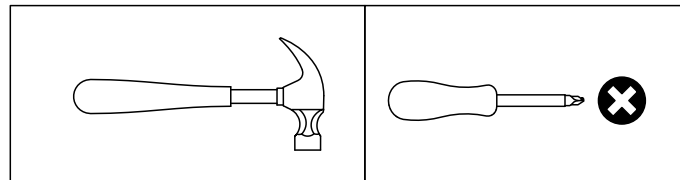

# STEP 1

## PARTS REQUIRED

8 - BASE x1

## HARDWARE REQUIRED

A  04  
Ø 8 x 30mm

D  04  
Ø 3,0 x 14mm

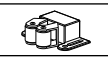
E  02

## TOOLS REQUIRED

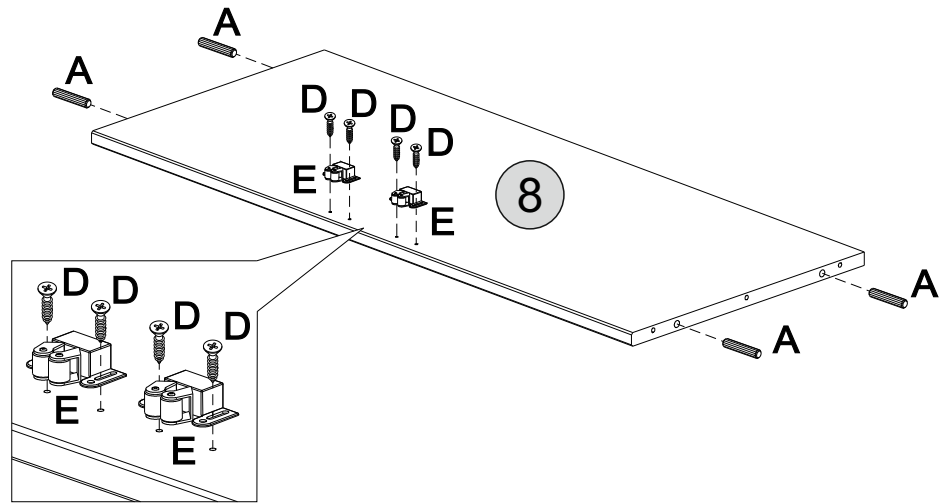
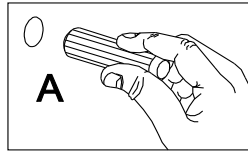
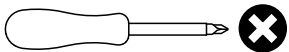

Please assemble on a clean soft surface to avoid damage.

# STEP 2

## PARTS REQUIRED

1 - RIGHT SIDE PANEL x1

2 - LEFT SIDE PANEL x1

## HARDWARE REQUIRED

A  10  
Ø 8 x 30mm

K  04

## TOOLS REQUIRED

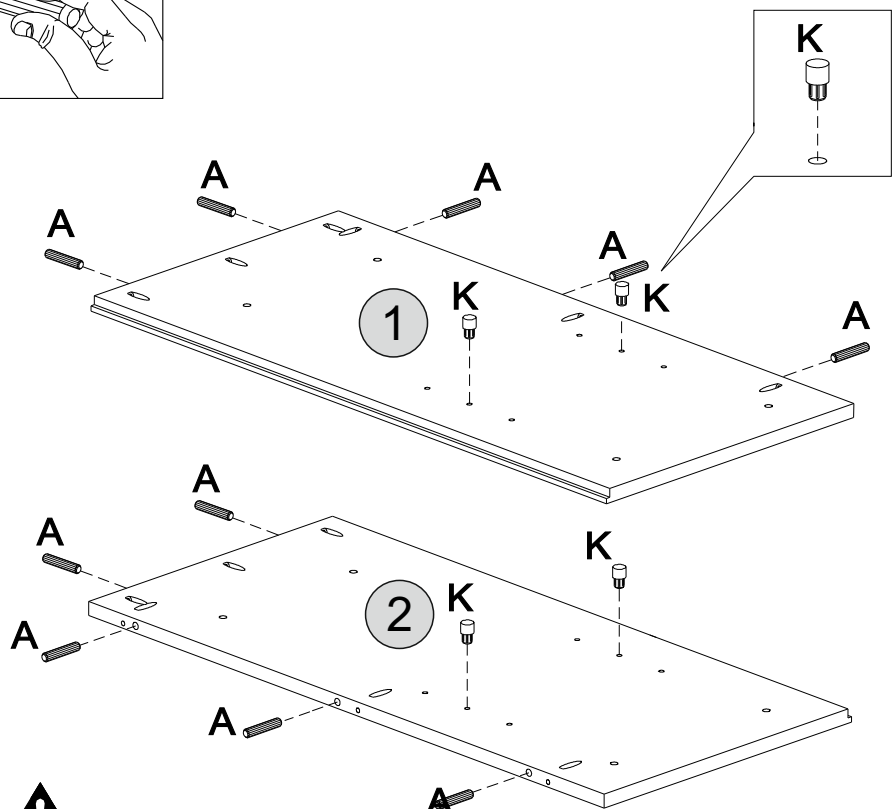
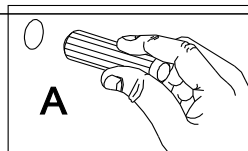
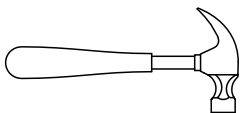
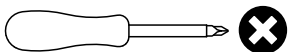

Please assemble on a clean soft surface to avoid damage.

# STEP 3

## PARTS REQUIRED

- 1 - RIGHT SIDE PANEL x1
- 2 - LEFT SIDE PANEL x1
- 3 - RIGHT FRONT UPRIGHT x1
- 4 - LEFT FRONT UPRIGHT x1

## HARDWARE REQUIRED

- B  06  
Ø 3,5 x 30mm

## TOOLS REQUIRED

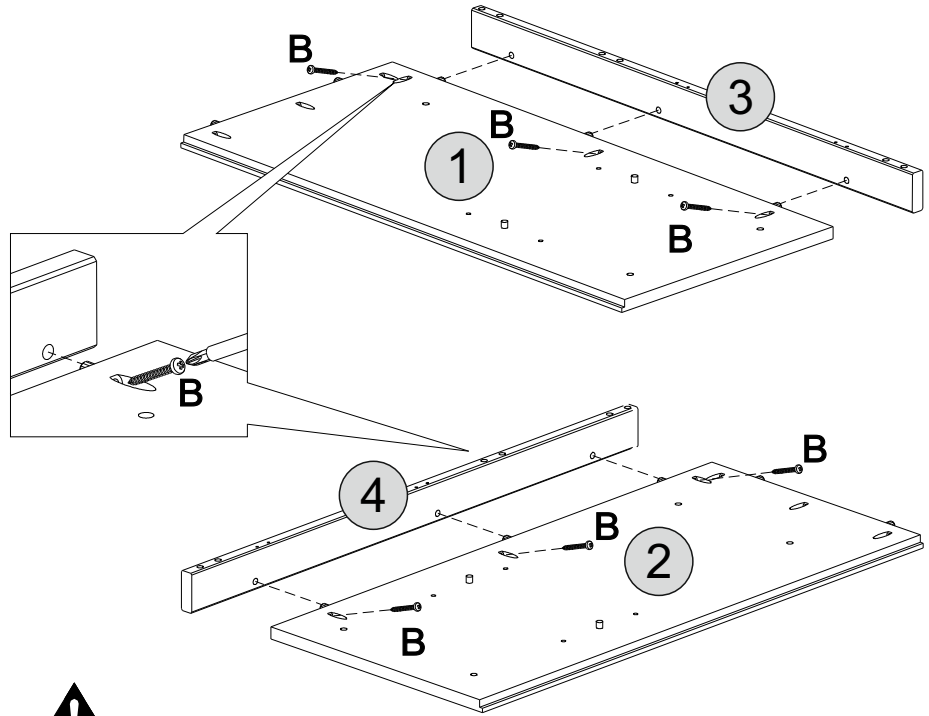
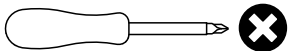

Please assemble on a clean soft surface to avoid damage.

# STEP 4

## PARTS REQUIRED

- 6 - DRAWER RUNNER x2
- 15 - BACK UPRIGHT x1
- 16 - CENTRE DRAWER RUNNER x1
- 17 - CENTRE FRONT UPRIGHT x1

## HARDWARE REQUIRED

- A  14  
Ø 6 x 30mm

## TOOLS REQUIRED

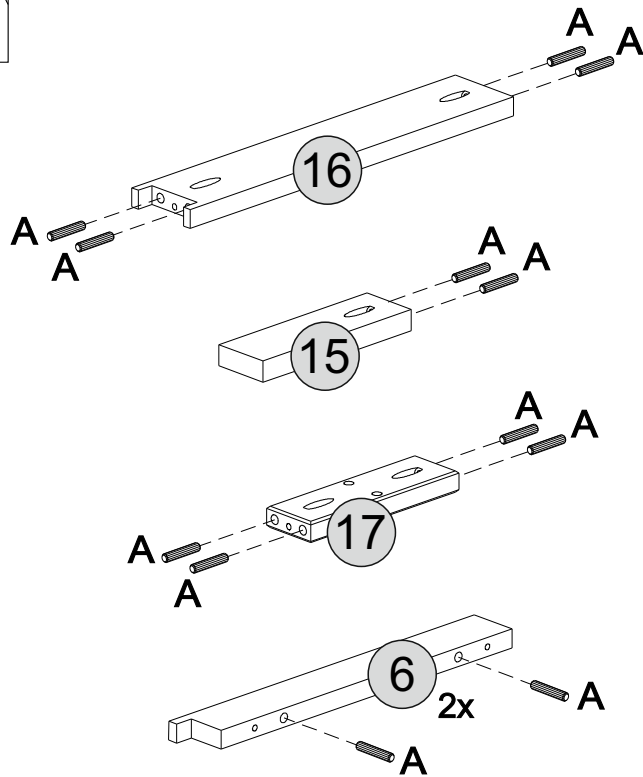
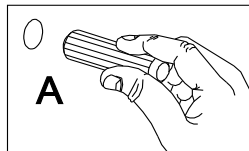

Please assemble on a clean soft surface to avoid damage.

# STEP 5

## PARTS REQUIRED

- 7 - BOTTOM FRONT CROSSBEAM x1
- 14 - CENTRE FRONT UPRIGHT x1
- 18 - CENTRE FRONT CROSSBEAM x1
- 22 - TOP FRONT CROSSBEAM x1

## HARDWARE REQUIRED

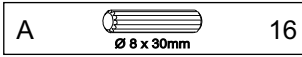

## TOOLS REQUIRED

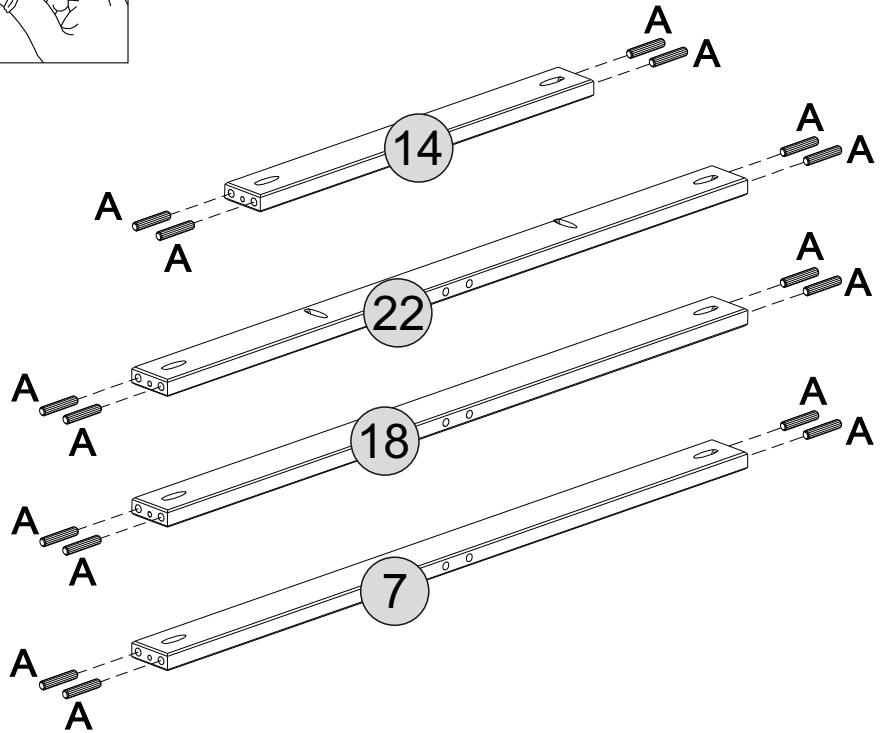
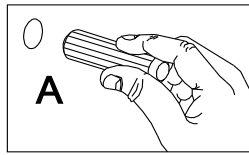

Please assemble on a clean soft surface to avoid damage.

# STEP 6

## PARTS REQUIRED

- 7 - BOTTOM FRONT CROSSBEAM x1
- 14 - CENTRE FRONT UPRIGHT x1
- 17 - CENTRE FRONT UPRIGHT x1
- 18 - CENTRE FRONT CROSSBEAM x1
- 22 - TOP FRONT CROSSBEAM x1

## HARDWARE REQUIRED



## TOOLS REQUIRED

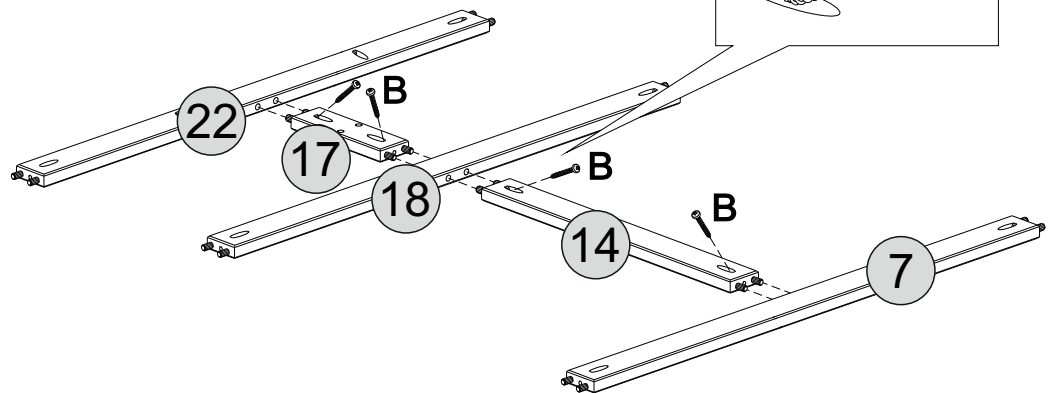
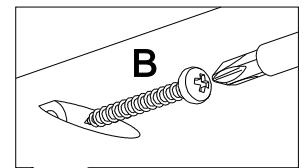
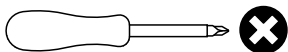

Please assemble on a clean soft surface to avoid damage.



# STEP 7

## PARTS REQUIRED

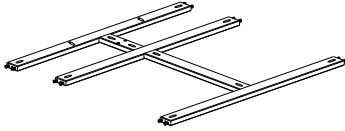
- 1 - RIGHT SIDE PANEL x1
- 2 - LEFT SIDE PANEL x1
- 8 - BASE x1



## HARDWARE REQUIRED

- B  12  
Ø 3,5 x 30mm
- D  02  
Ø 3,0 x 14mm
- N  01

## TOOLS REQUIRED

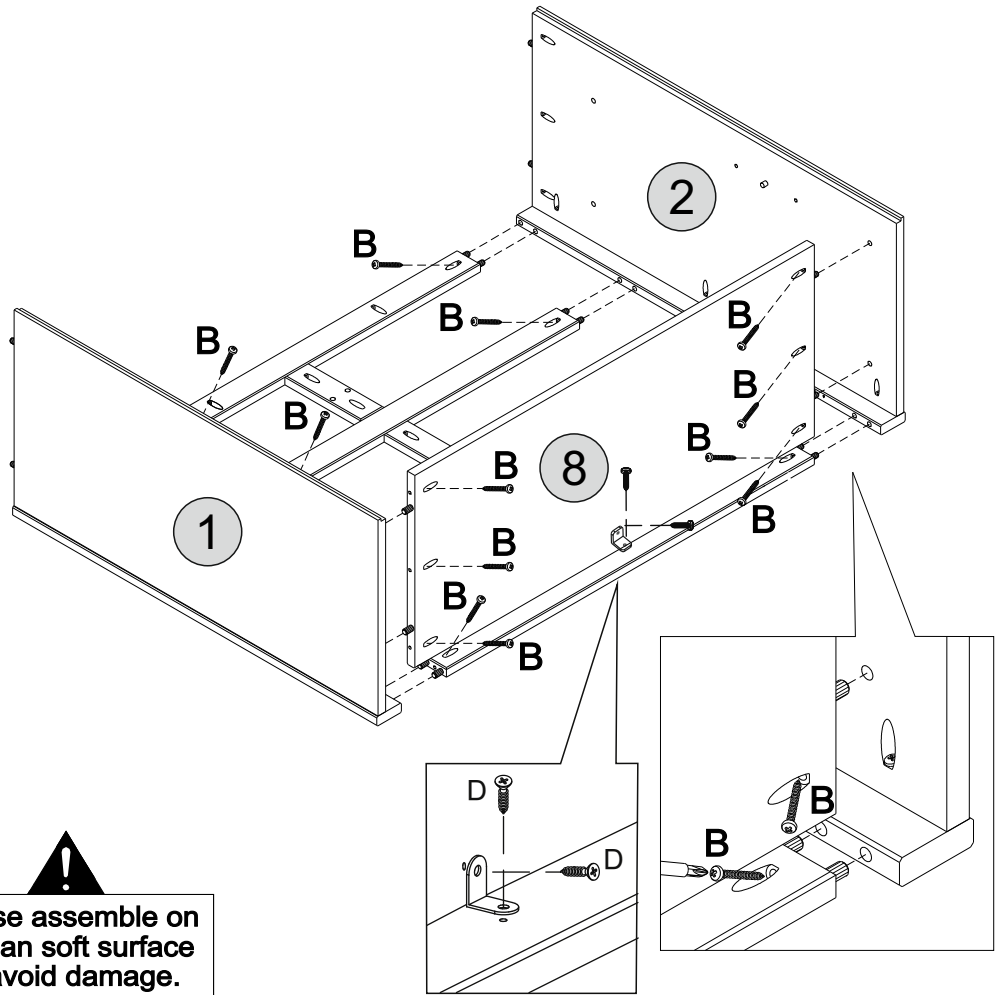
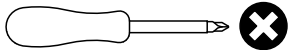

**!**  
Please assemble on a clean soft surface to avoid damage.

# STEP 8

## PARTS REQUIRED

- 5 - TOP PANEL x1

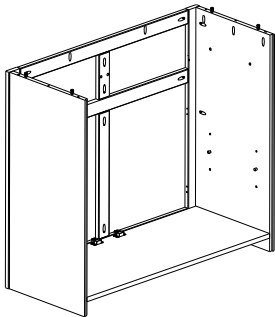

## HARDWARE REQUIRED

- B  08  
Ø 3,5 x 30mm

## TOOLS REQUIRED

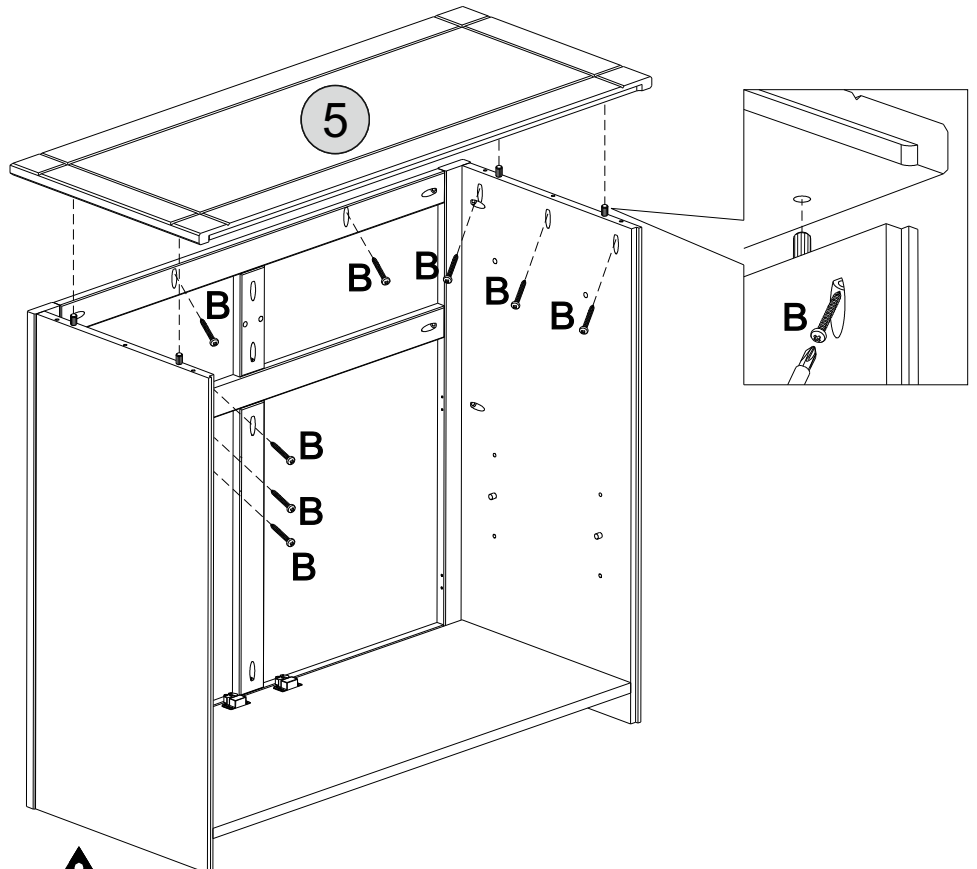
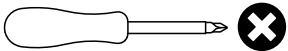

**!**  
Please assemble on a clean soft surface to avoid damage.

# STEP 9

## PARTS REQUIRED

- 6 - DRAWER RUNNER x2
- 15 - BACK UPRIGHT x1
- 16 - CENTRE DRAWER RUNNER x1
- 19 - ADJUSTABLE SHELF x1

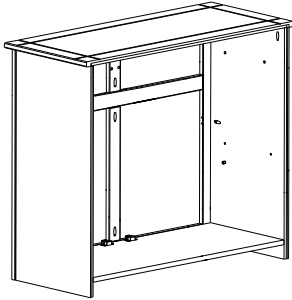

## HARDWARE REQUIRED

- B  07  
Ø 3,5 x 30mm

## TOOLS REQUIRED

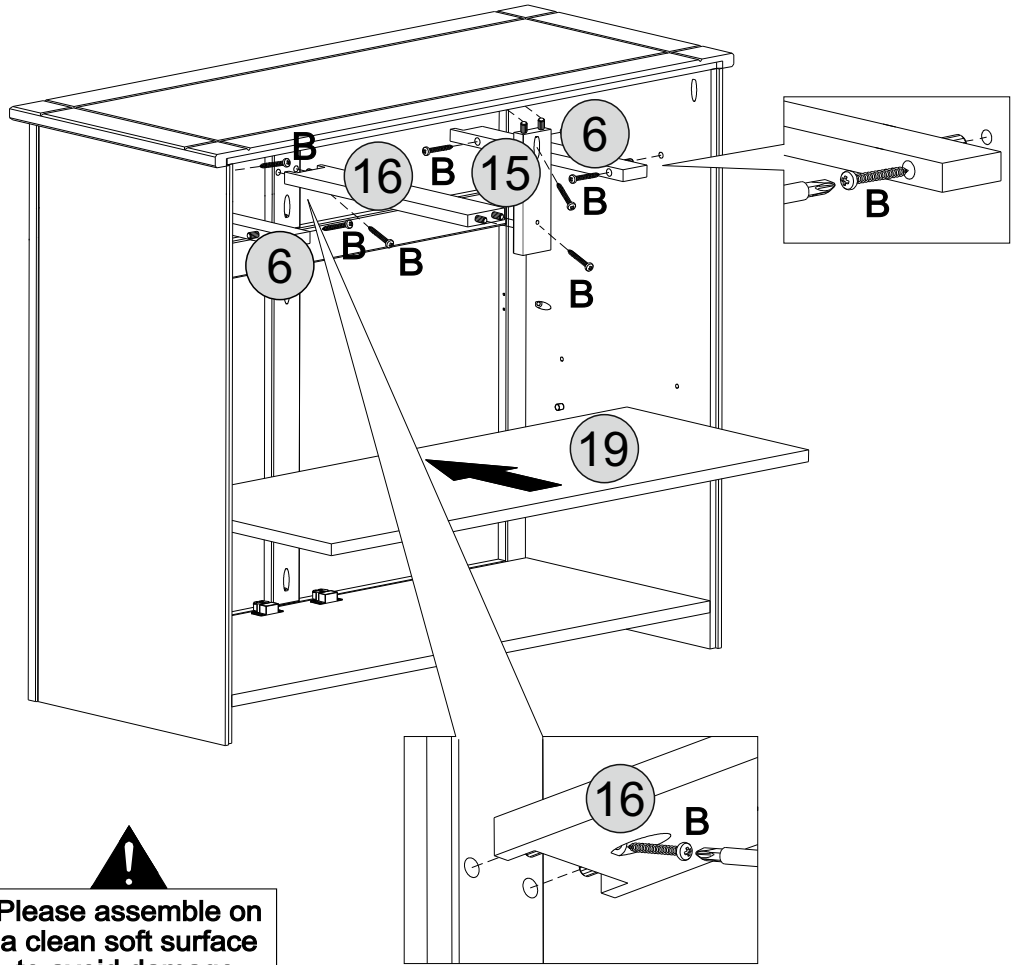
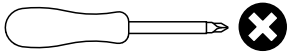



# STEP 10

## PARTS REQUIRED

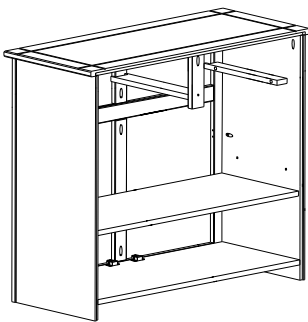
- 9- BACK PANEL x2



## HARDWARE REQUIRED

- J  26  
10 x 10mm
- L  01

## TOOLS REQUIRED

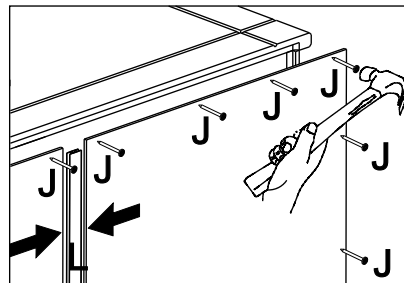
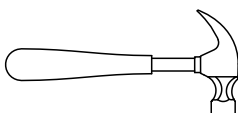

For your future reference order number should be here

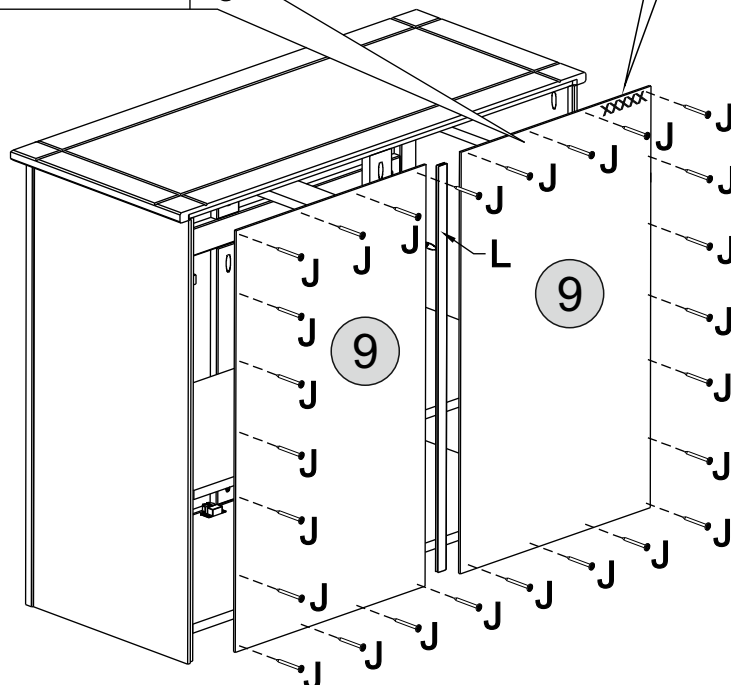





# STEP 11

## PARTS REQUIRED

10 - DRAWER FRONT	x2
11 - DRAWER SIDE	x4
12 - DRAWER BOTTOM	x2
13 - DRAWER BACK	x2

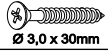
## HARDWARE REQUIRED

C	 16 Ø 3,0 x 30mm
F	 02
G	 02 M4 x 25mm

## TOOLS REQUIRED

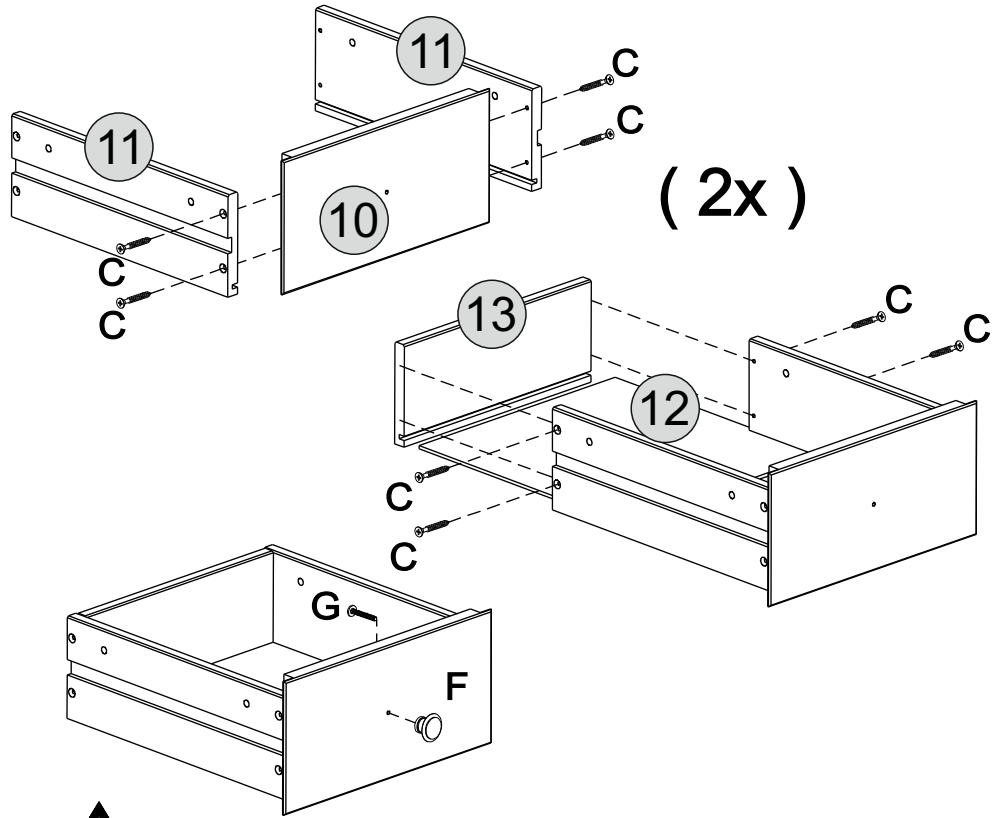
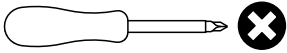

 Please assemble on a clean soft surface to avoid damage.

# STEP 12

## PARTS REQUIRED

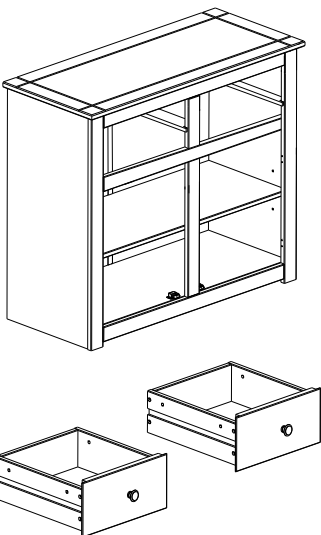

## HARDWARE REQUIRED

A	 04 Ø 8 x 30mm
---	------------------------------------------------------------------------------------------------------

## TOOLS REQUIRED

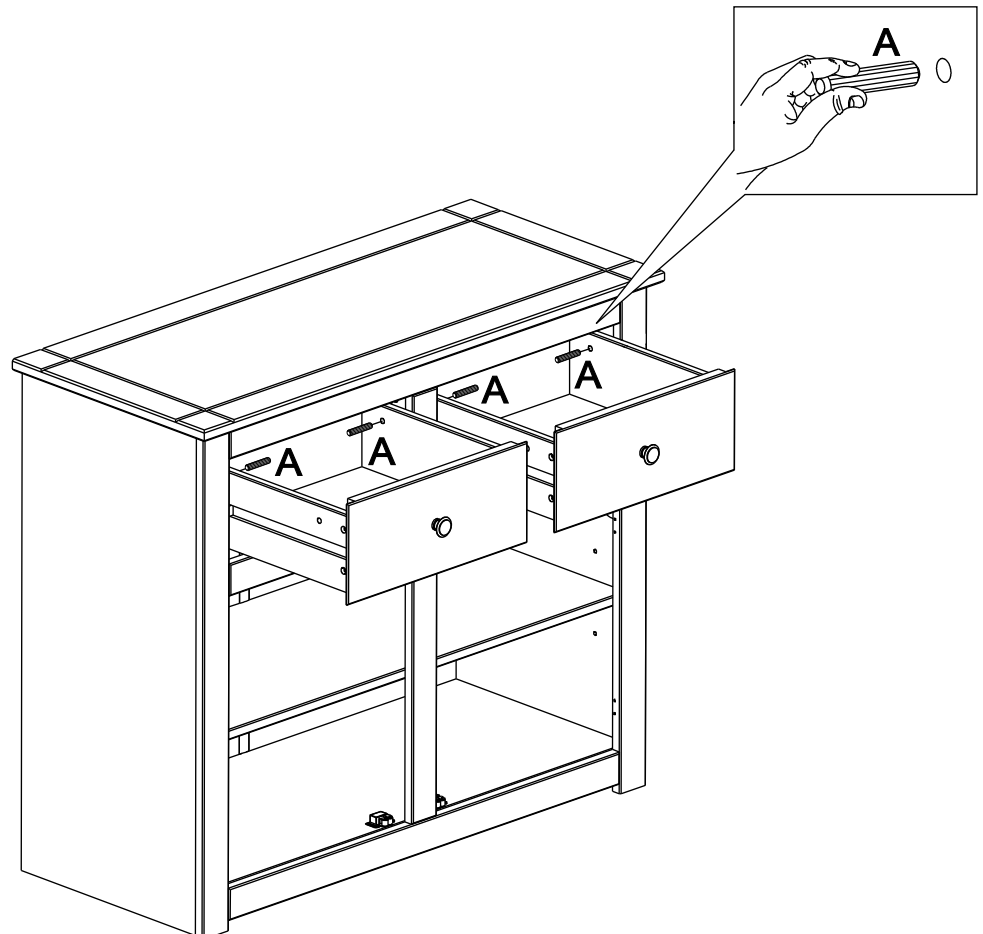

# STEP 13

## PARTS REQUIRED

20 - RIGHT DOOR x1

21 - LEFT DOOR x1

## HARDWARE REQUIRED

D  12  
Ø 3,0 x 14mm

E  02

H  02  
Right

I  02  
Left

## TOOLS REQUIRED

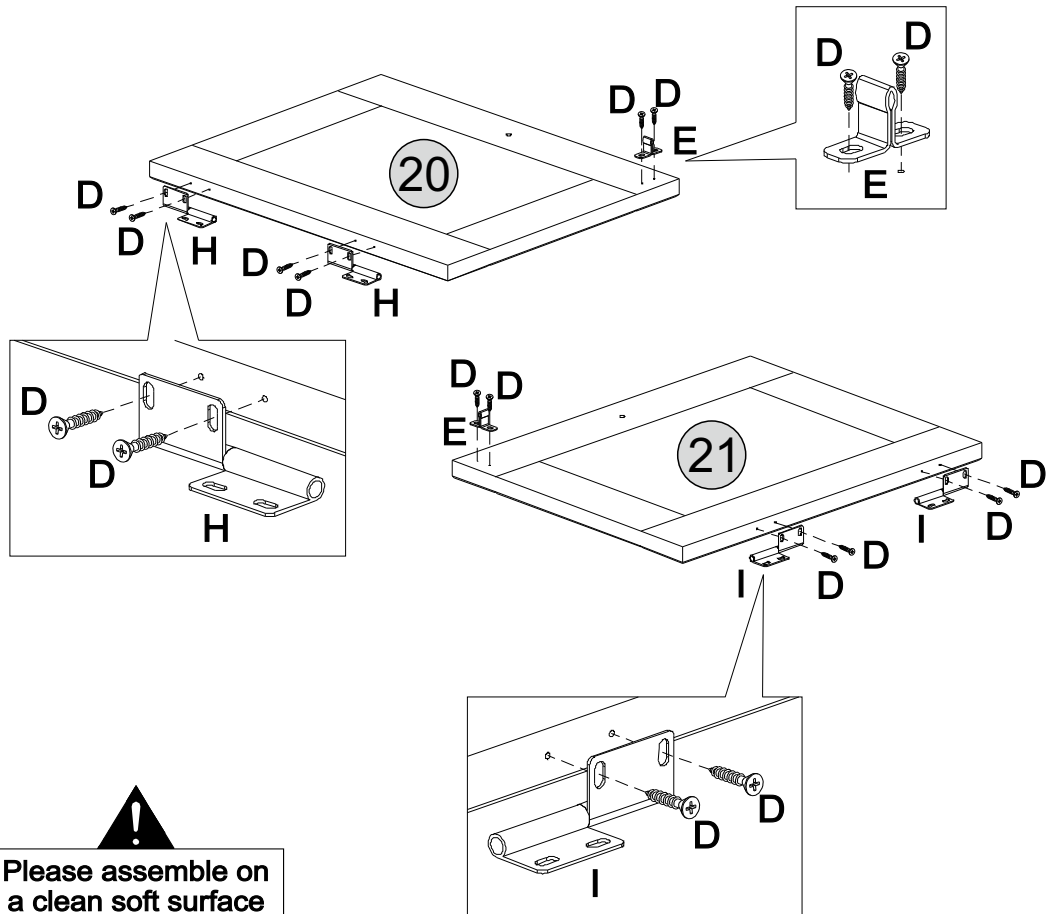
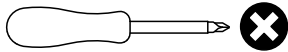

# STEP 14

## PARTS REQUIRED

20 - RIGHT DOOR x1

21 - LEFT DOOR x1

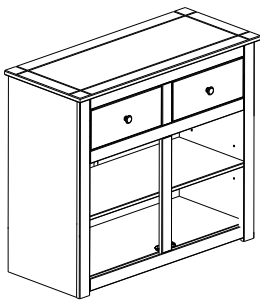

## HARDWARE REQUIRED

D  08  
Ø 3,0 x 14mm

F  02

G  02  
M4 x 25mm

## TOOLS REQUIRED

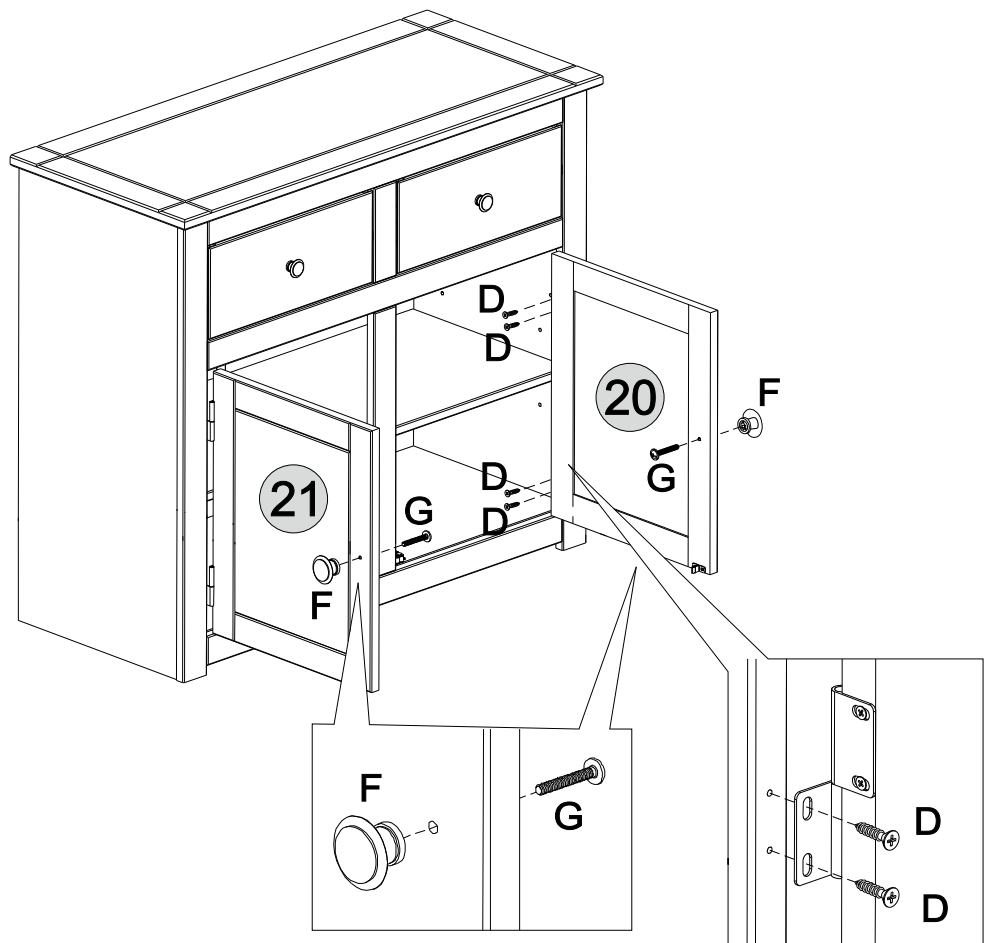
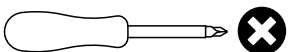

# STEP 15

## PARTS REQUIRED

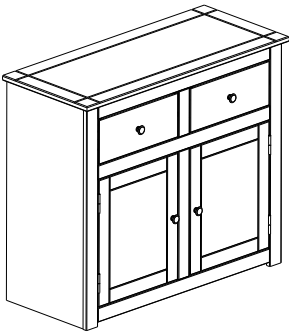

## HARDWARE REQUIRED

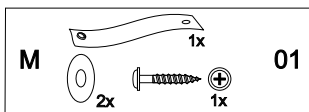

## TOOLS REQUIRED

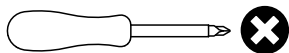

## WARNING

**Serious or fatal injuries can occur from furniture tipping over. To prevent the furniture from tipping over we recommend that it is permanently fixed to the wall.**

Wall fixings are not supplied with this product as different wall materials require different types of fixing devices. Please make sure you use fixings suitable for the walls in your home.

