

GREY GLOSS SEVILLE 2 DOOR 1 DRAWER WARDROBE ASSEMBLY INSTRUCTIONS

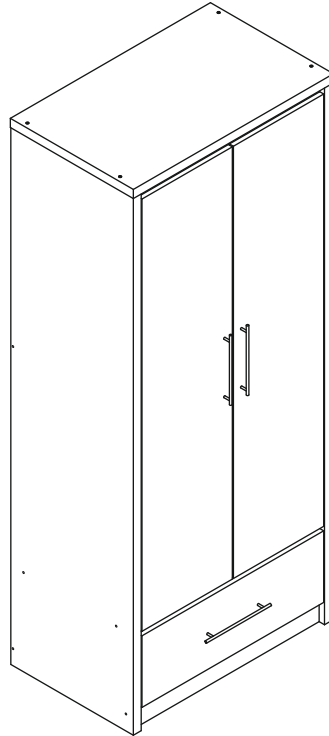

**FOR DOMESTIC USE ONLY
IMPORTANT**

PLEASE READ BEFORE YOU CONTINUE FURTHER

THE PRODUCT YOU HAVE PURCHASED WILL GIVE YOU MANY YEARS OF SERVICE IF YOU FOLLOW THE GUIDELINES FOR ITS SAFE ASSEMBLY AND PERIODIC MAINTENANCE AND CLEANING.

ASSEMBLE ON A SOFT CLEAN SURFACE.

DO NOT USE ANY TOOLS OTHER THAN THOSE SHOWN.

ANY SPANNERS OR ALLEN KEYS REQUIRED ARE INCLUDED WITH THE FITTING KIT.

DO NOT FOR ANY REASON USE A POWER TOOL TO ASSEMBLE THIS PRODUCT. ITS USE WILL INVALIDATE ANY CLAIM YOU MAY HAVE AND COULD MAKE THIS PRODUCT UNSAFE.

DEPENDING ON THE AMOUNT OF USE THIS PRODUCT RECEIVES, IT MAY BE NECESSARY TO TIGHTEN UP THE FIXINGS FROM TIME TO TIME. THIS IS COMPLETELY NORMAL FOR ANY FLAT PACK FURNITURE. DO NOT OVERTIGHTEN FIXINGS.

FOR CLEANING, YOU MAY USE A DAMP CLOTH (NOT WET). DO NOT USE POLISH, DETERGENT OR CHEMICAL CLEANERS.

THE SURFACE OF THIS ITEM IS NOT HEAT RESISTANT. ALWAYS USE A PLACE MAT UNDER HOT OR COLD ITEMS TO PREVENT MARKING.



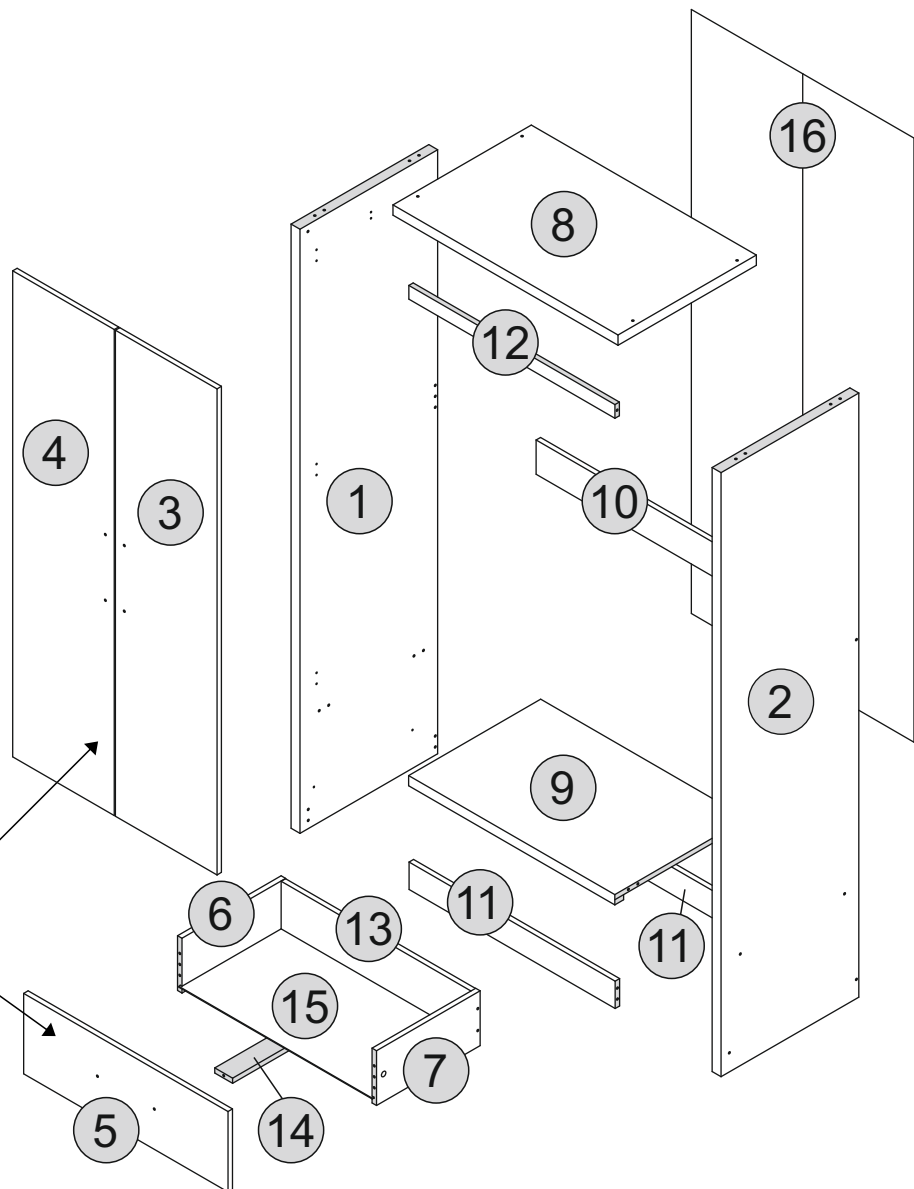

 PLEASE NOTE THE CLEAR PROTECTIVE FILM WHICH NEEDS REMOVING FROM THE GLOSS FINISH.



PART LIST

Part Number	Part Code	Part Description	Quantity	Carton
1	S100-101-072-ZF1-01	Left Side Panel	1	1/2
2	S100-101-072-ZF1-02	Right Side Panel	1	1/2
3	S100-101-072-ZF1-03	Right Door	1	1/2
4	S100-101-072-ZF1-04	Left Door	1	1/2
5	S100-101-072-ZF1-05	Drawer Front	1	2/2
6	S100-101-072-ZF1-06	Left Drawer Side	1	1/2
7	S100-101-072-ZF1-07	Right Drawer Side	1	1/2
8	S100-101-072-ZF1-08	Top Panel	1	2/2
9	S100-101-072-ZF1-09	Shelf Panel	1	2/2
10	S100-101-072-ZF1-10	Back Support Panel	1	2/2
11	S100-101-072-ZF1-11	Crossbar	2	2/2
12	S100-101-072-ZF1-12	Support Panel	1	2/2
13	S100-101-072-ZF1-13	Drawer Back	1	2/2
14	S100-101-072-ZF1-14	Drawer Support	1	2/2
15	S100-101-072-ZF1-15	Drawer Base	1	2/2
16	S100-101-072-ZF1-16	Back Panel	1	1/2

HARDWARE LIST

No	Part Name		Qty	Carton
A	M6x25mm Wooden Dowel		x22	1
B	M4x65mm Screw		x14	1
C	M3.5x14mm Screw		x42	1
D	M4x65mm Screw		x5	1
E	Minifix Cam Bolt (8032t)		x3	1
F	Minifix Cam Nut (1512)		x3	1
G	10" Handle (192mm)		x3	1
H	20mm Handle Screw		x6	1
I	14" Drawer Slide (VKT-9W)		x1	1
J	PVC L-Bracket		x1	1
K	Plastic Foot		x6	1
L	6/8" Nail		x60	1
M	Wall Fixing (4x20mm= 1pc)		x1	1
N	Screw Cover (Sticker 12mm)		x10	1
O	Hanging Rail Support		x2	1
P	Hanging Rail (689mm)		x1	2
Q	Hinges (M11)		x6	1

TIPS FOR FITTINGS CAM-LOCKS

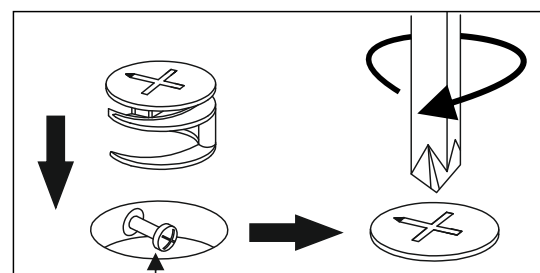
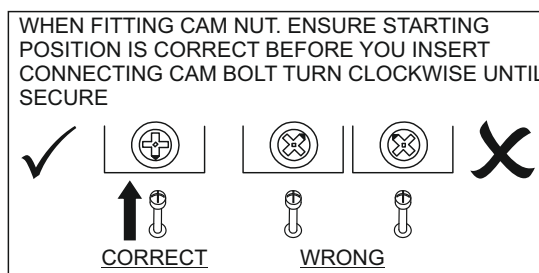

Cam bolt head needs to be in centre

CAMBOLT

Tighten until shoulder is flush with panel. Do not overtighten or undertighten (see example below)

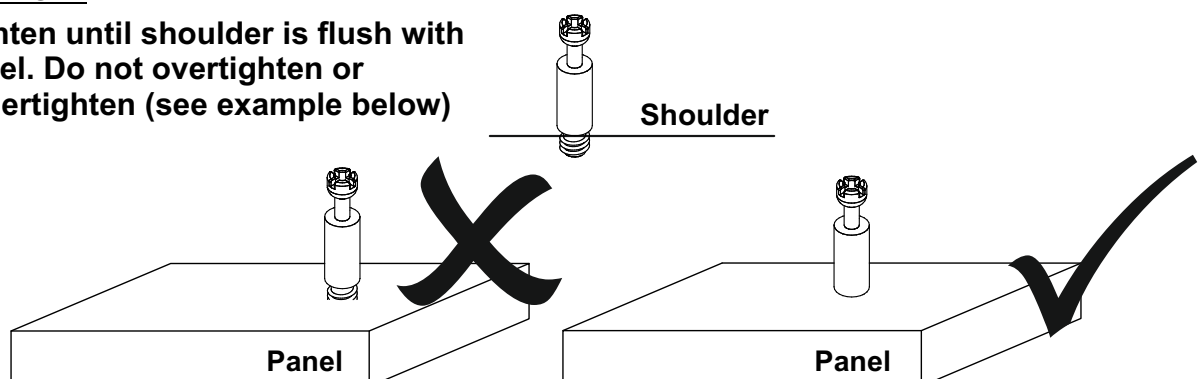

STEP 1

PARTS REQUIRED

1 - LEFT SIDE PANEL x1

2 - RIGHT SIDE PANEL x1

HARDWARE REQUIRED

A  04

C  08
3.5x14mm

I  01

O  02

TOOLS REQUIRED

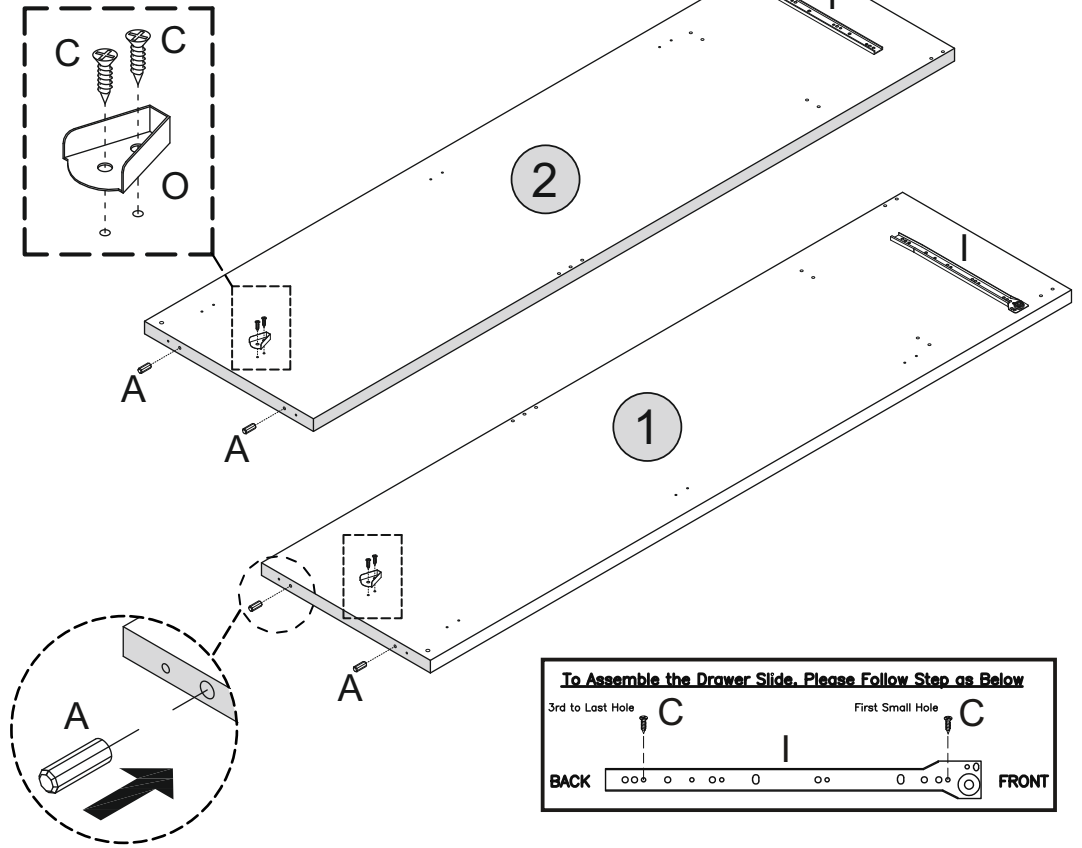
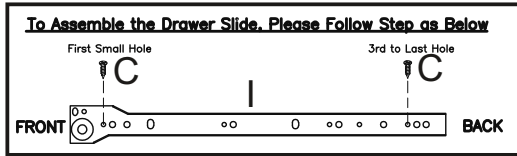
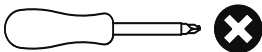
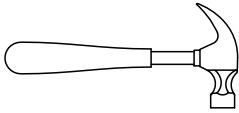

STEP 2

PARTS REQUIRED

9 - SHELF PANEL x1

10 - BACK SUPPORT PANEL x1

11 - CROSSBAR x2

12 - SUPPORT PANEL x1

HARDWARE REQUIRED

A  14

TOOLS REQUIRED

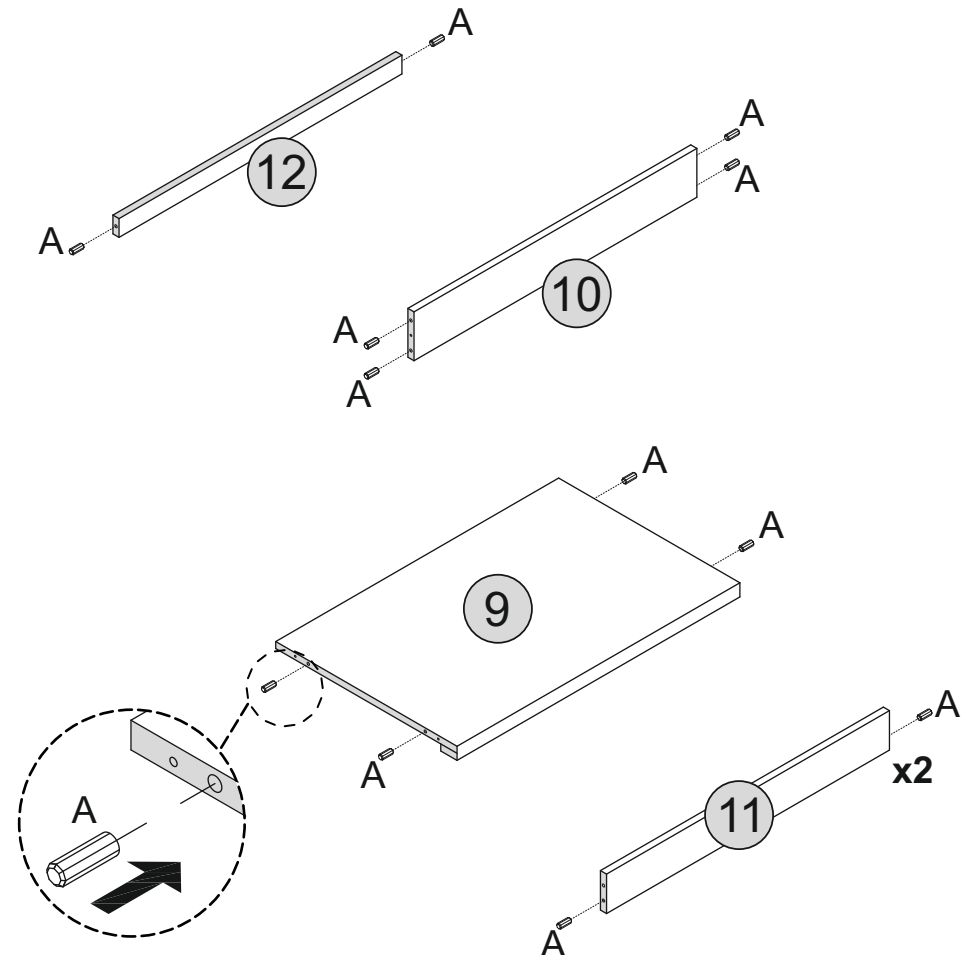
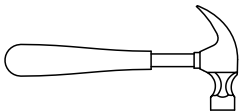

STEP 3

PARTS REQUIRED

8 - TOP PANEL x1

HARDWARE REQUIRED

C  02
3.5x14mm

J  01

TOOLS REQUIRED

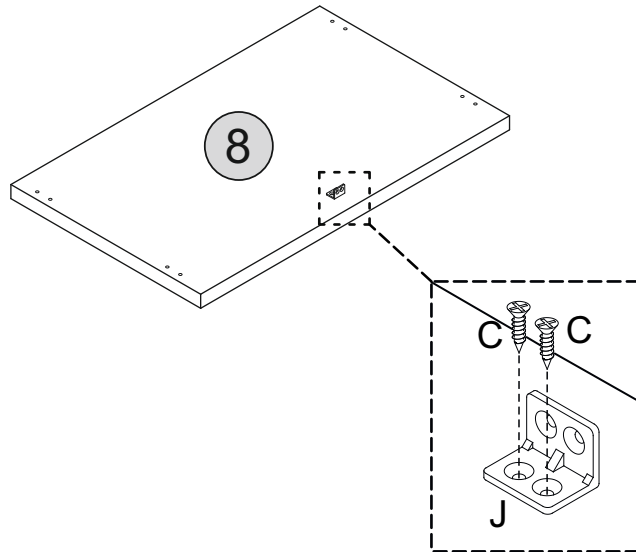
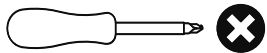

STEP 4

PARTS REQUIRED

1 - LEFT SIDE PANEL x1

9 - SHELF PANEL x1

10 - BACK SUPPORT PANEL x1

11 - CROSSBAR x2

12 - SUPPORT PANEL x1

HARDWARE REQUIRED

B  05
4x65mm

TOOLS REQUIRED

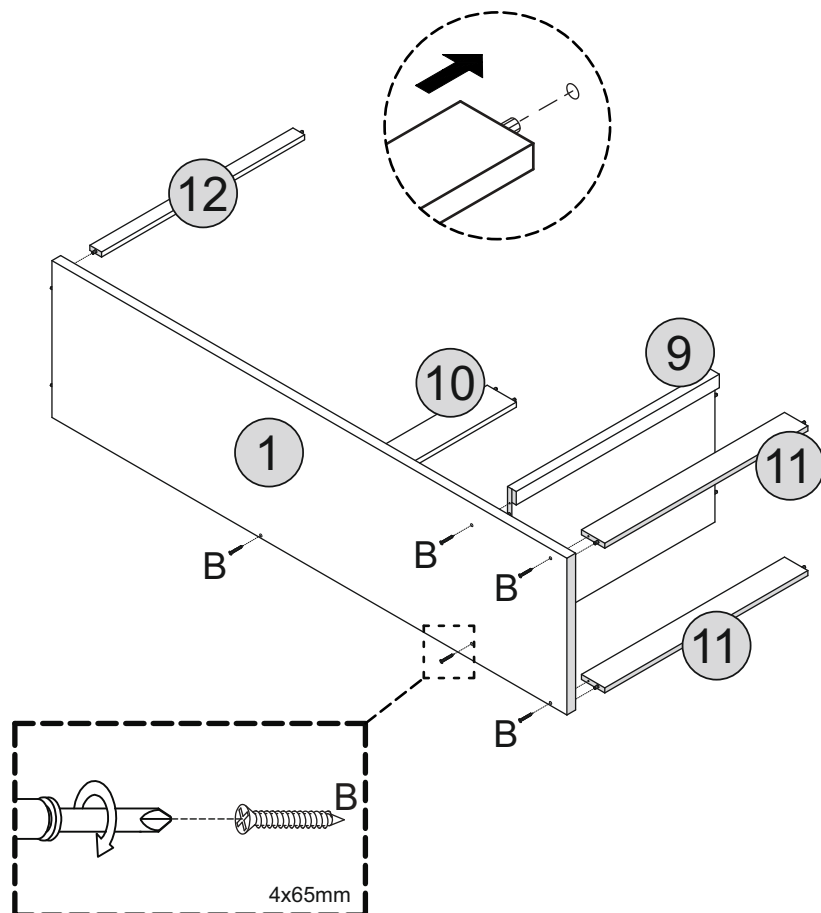
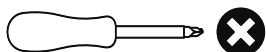

STEP 5

PARTS REQUIRED

2 - RIGHT SIDE PANEL x1

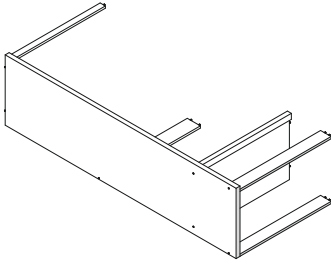

HARDWARE REQUIRED

B  05

TOOLS REQUIRED

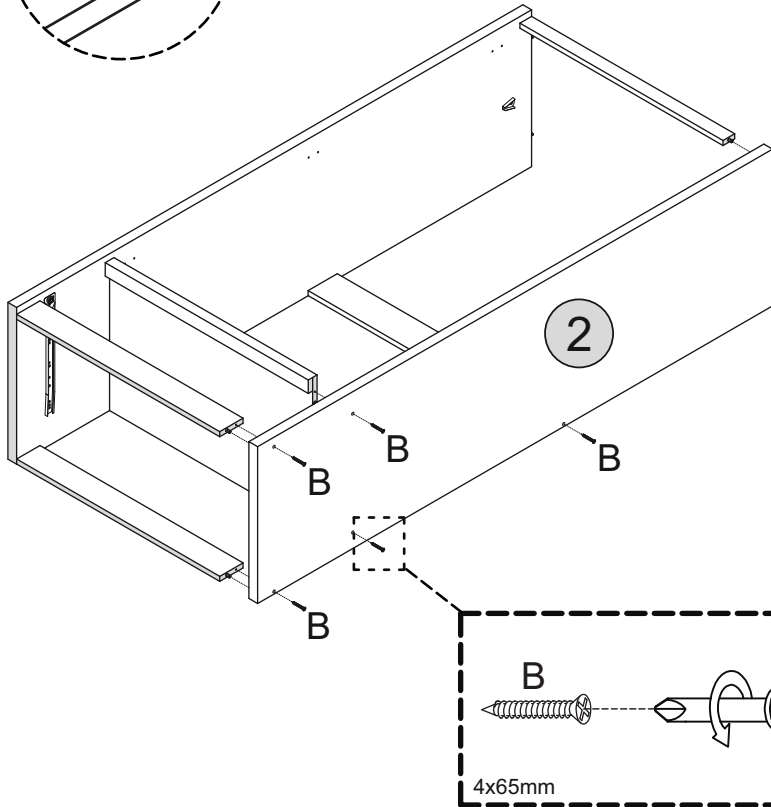
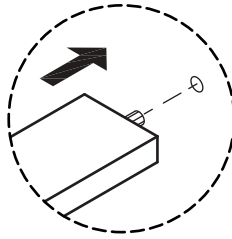
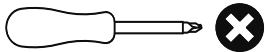

STEP 6

PARTS REQUIRED

8 - TOP PANEL x1

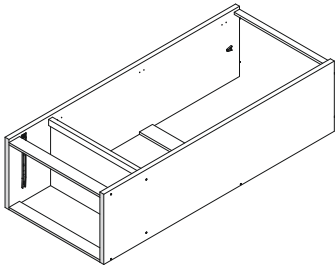

HARDWARE REQUIRED

B  04

TOOLS REQUIRED

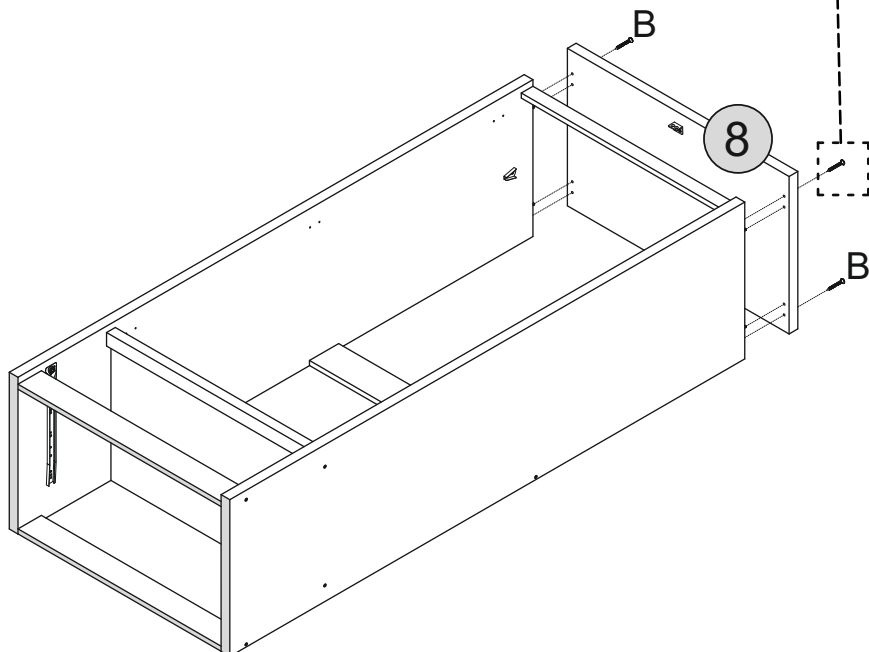
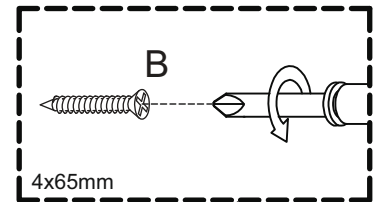
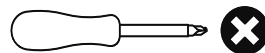

STEP 7

PARTS REQUIRED

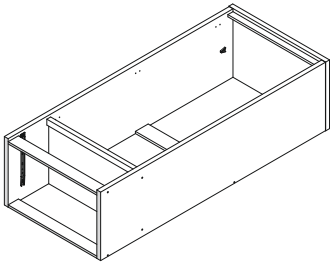

HARDWARE REQUIRED

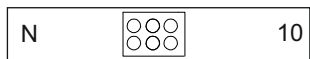
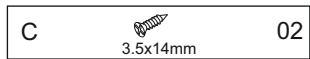

TOOLS REQUIRED

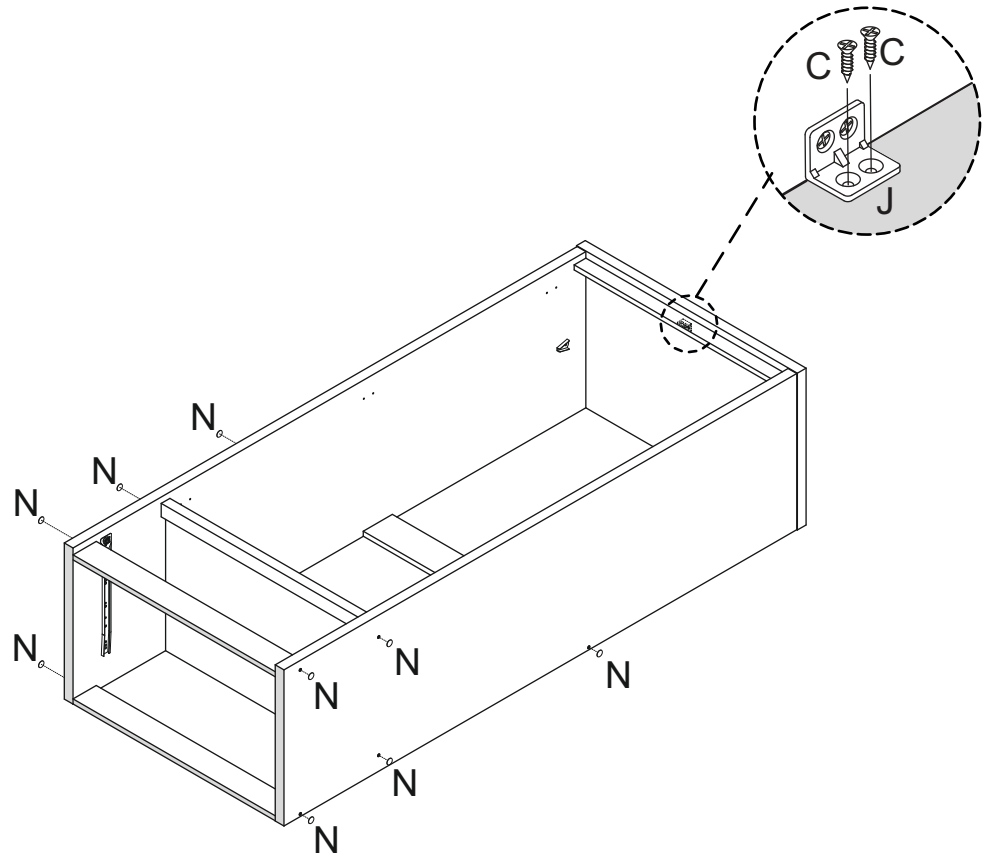
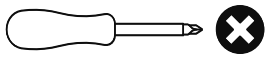

STEP 8

PARTS REQUIRED

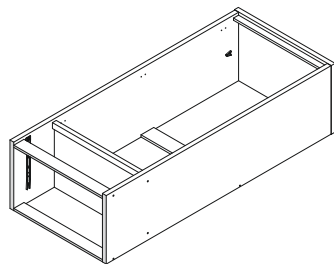

HARDWARE REQUIRED

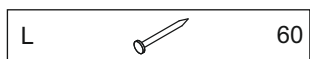
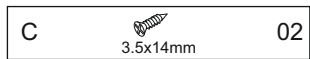

TOOLS REQUIRED

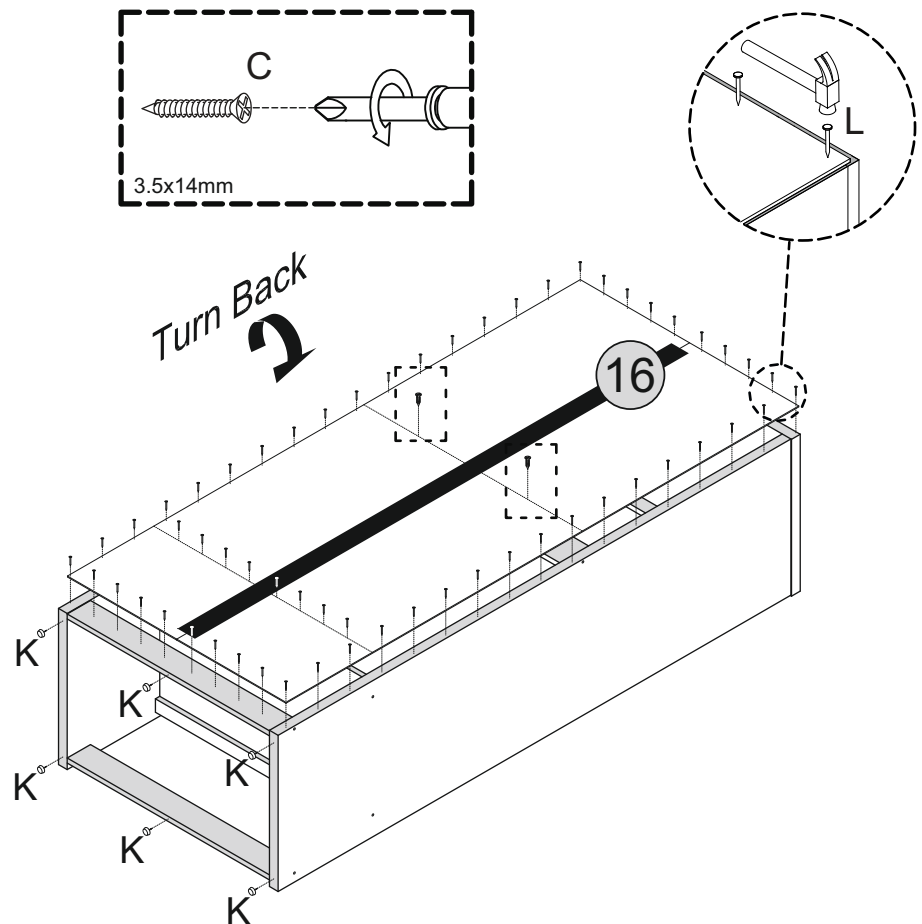
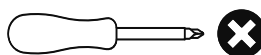
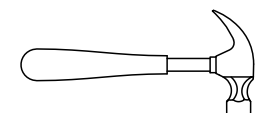



STEP 9

PARTS REQUIRED

5 - DRAWER FRONT	x1
6 - LEFT DRAWER SIDE	x1
7 - RIGHT DRAWER SIDE	x1
14 - DRAWER SUPPORT	x1

HARDWARE REQUIRED

A		04
E		03
F		03

TOOLS REQUIRED

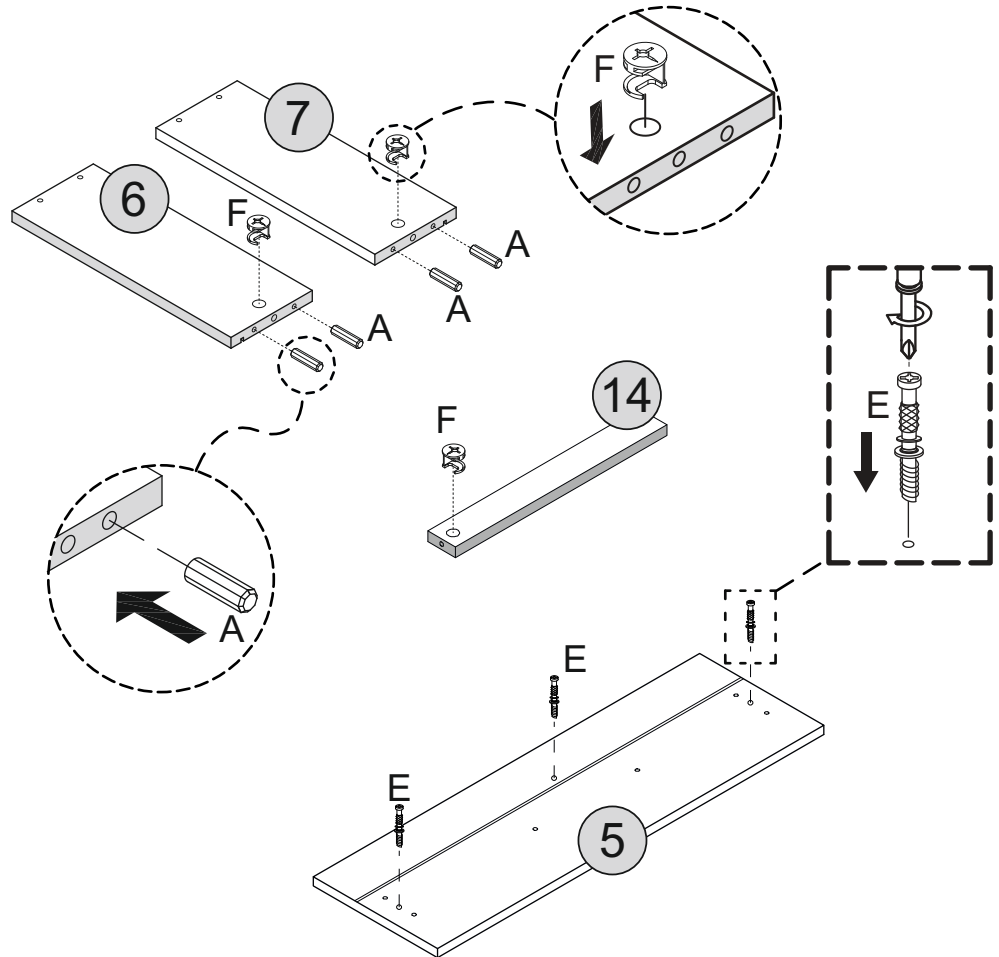
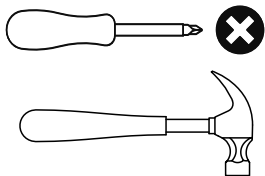

STEP 10

PARTS REQUIRED

6 - LEFT DRAWER SIDE	x1
7 - RIGHT DRAWER SIDE	x1
13 - DRAWER BACK	x1
14 - DRAWER SUPPORT	x1
15 - DRAWER BASE	x1

HARDWARE REQUIRED

D	 4x38mm	05
---	--	----

TOOLS REQUIRED

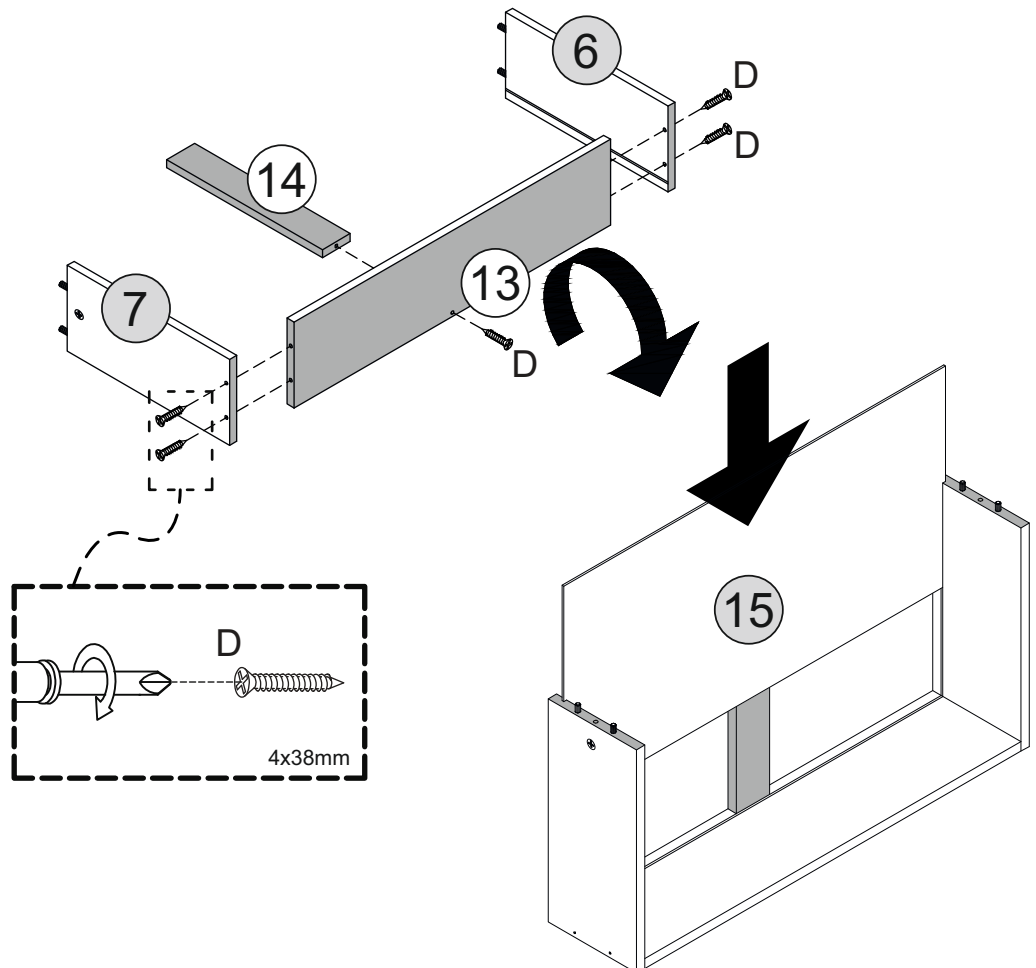
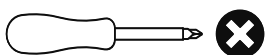

STEP 11

PARTS REQUIRED

5 - DRAWER FRONT x1

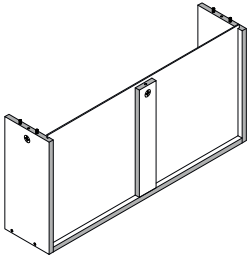

HARDWARE REQUIRED

TOOLS REQUIRED

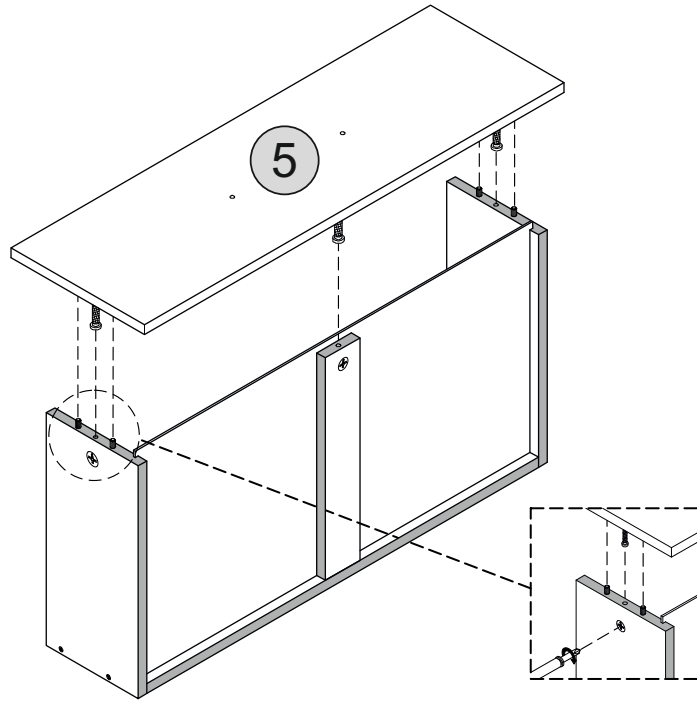
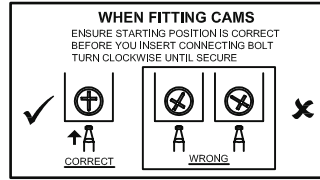
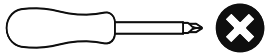

STEP 12

PARTS REQUIRED

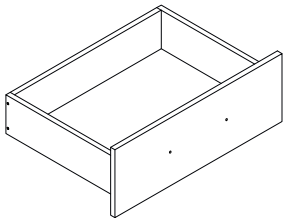

HARDWARE REQUIRED

G  01

H  02

TOOLS REQUIRED

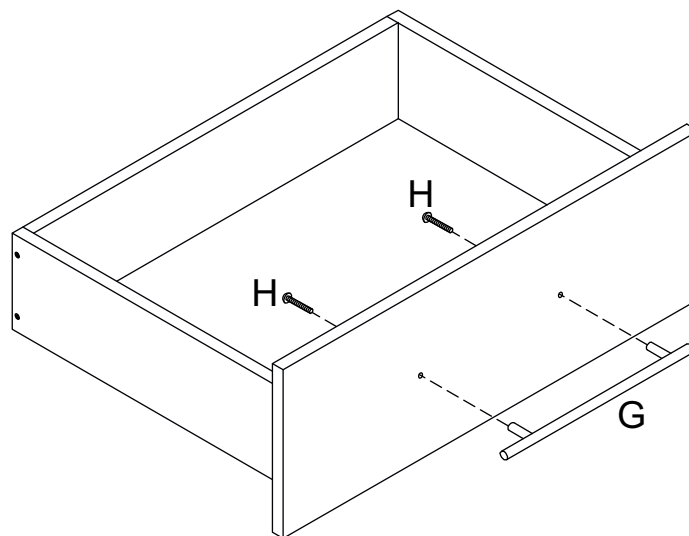
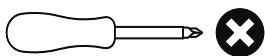

STEP 13

PARTS REQUIRED

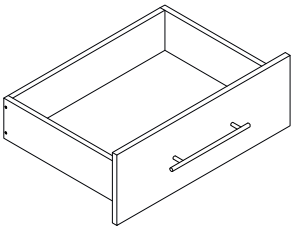

HARDWARE REQUIRED

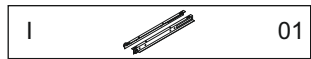
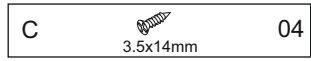

TOOLS REQUIRED

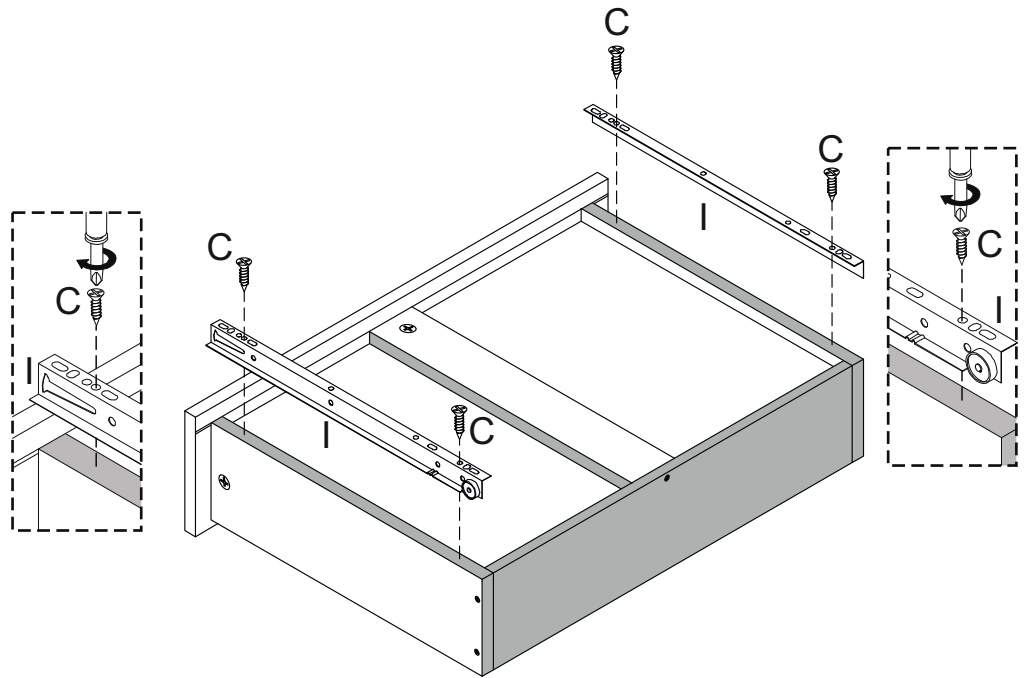
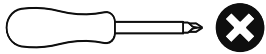

STEP 14

PARTS REQUIRED

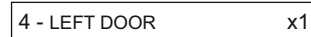

HARDWARE REQUIRED

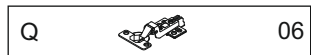
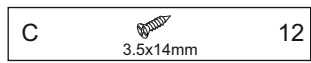

TOOLS REQUIRED

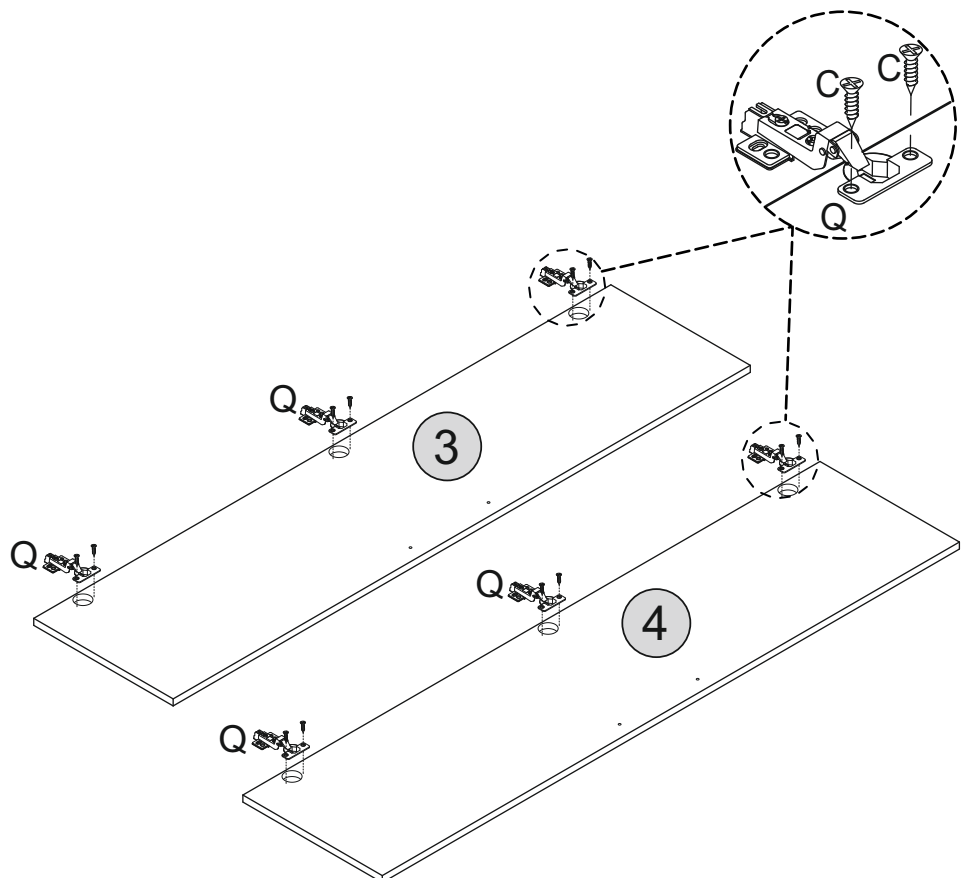
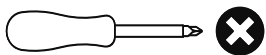

STEP 15

PARTS REQUIRED

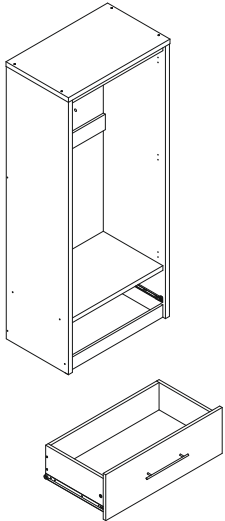

HARDWARE REQUIRED

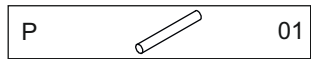

TOOLS REQUIRED

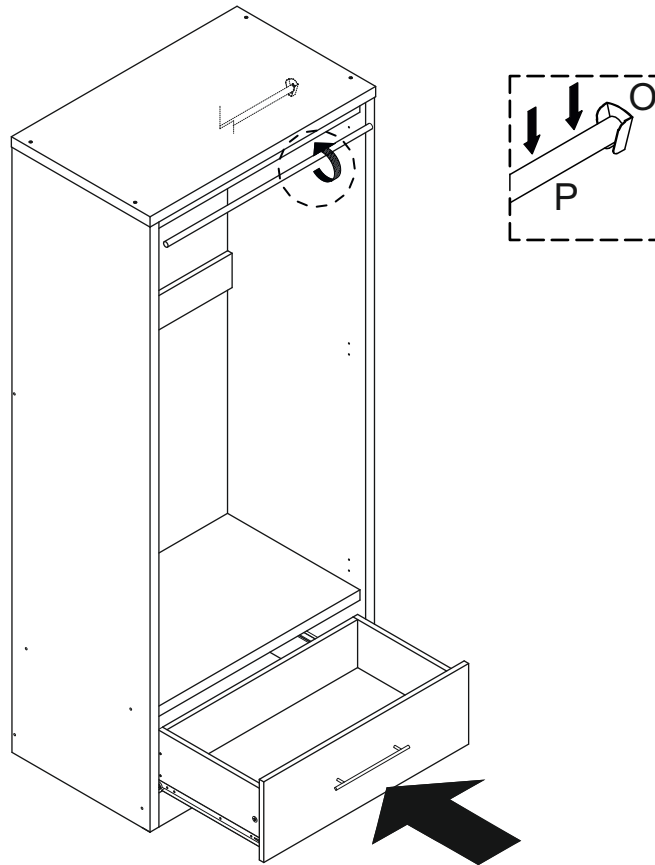

STEP 16

PARTS REQUIRED

- | | |
|----------------|----|
| 3 - RIGHT DOOR | x1 |
| 4 - LEFT DOOR | x1 |

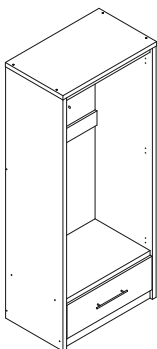

HARDWARE REQUIRED

- | | | |
|---|----------|----|
| C | 3.5x14mm | 12 |
| G | | 02 |
| H | | 04 |

TOOLS REQUIRED

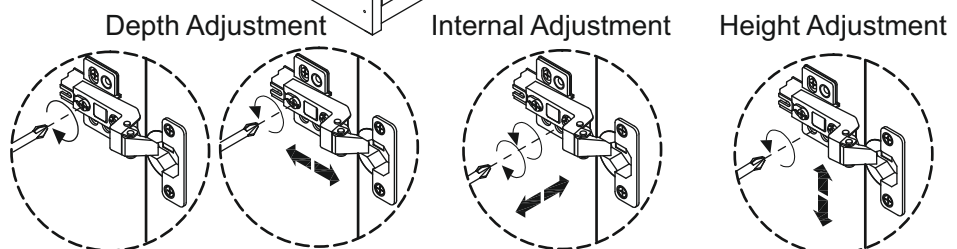
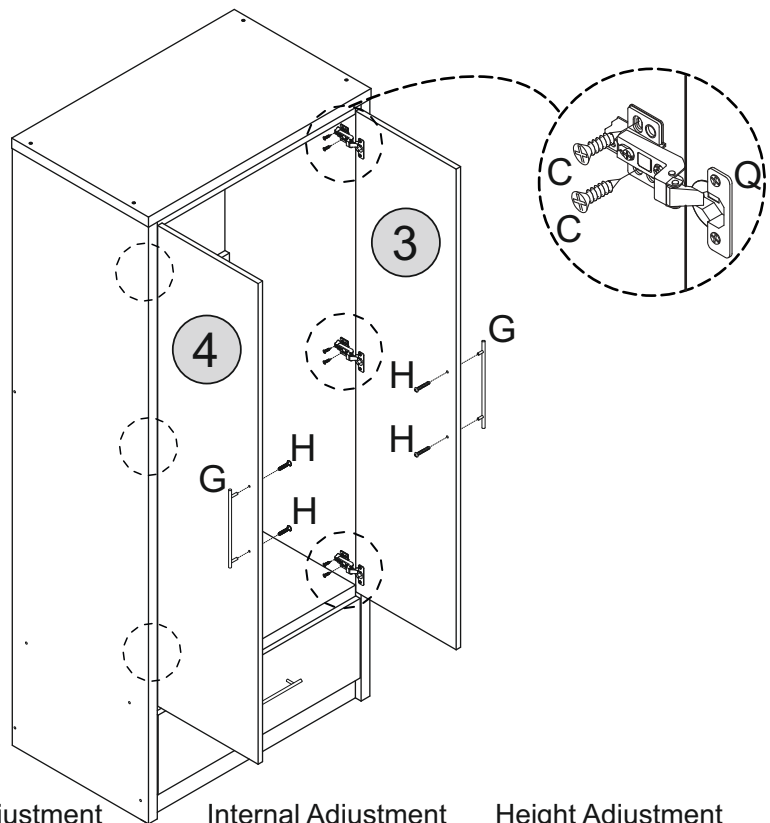
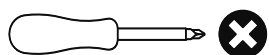

STEP 17

PARTS REQUIRED

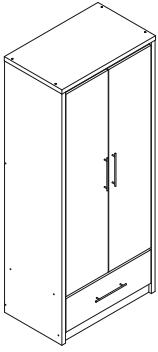

HARDWARE REQUIRED

M		01
---	---	----

TOOLS REQUIRED

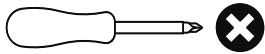

WARNING

Serious or fatal injuries can occur from furniture tipping over. To prevent the furniture from tipping over we recommend that it is permanently fixed to the wall.

Wall fixings are not supplied with this product as different wall materials require different types of fixing devices. Please make sure you use fixings suitable for the walls in your home.

