

NORDIC 3 DRAWER OCCASIONAL TABLE ASSEMBLY INSTRUCTIONS

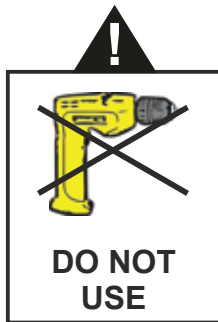

FOR DOMESTIC USE ONLY

IMPORTANT

PLEASE READ BEFORE YOU CONTINUE FURTHER

THE PRODUCT YOU HAVE PURCHASED WILL GIVE YOU MANY YEARS OF SERVICE IF YOU FOLLOW THE GUIDELINES FOR ITS SAFE ASSEMBLY AND PERIODIC MAINTENANCE AND CLEANING.

ASSEMBLE ON A SOFT CLEAN SURFACE.

DO NOT USE ANY TOOLS OTHER THAN THOSE SHOWN.

ANY SPANNERS OR ALLEN KEYS REQUIRED ARE INCLUDED WITH THE FITTING KIT.

DO NOT FOR ANY REASON USE A POWER TOOL TO ASSEMBLE THIS PRODUCT. ITS USE WILL INVALIDATE ANY CLAIM YOU MAY HAVE AND COULD MAKE THIS PRODUCT UNSAFE.

DEPENDING ON THE AMOUNT OF USE THIS PRODUCT RECEIVES, IT MAY BE NECESSARY TO TIGHTEN UP THE FIXINGS FROM TIME TO TIME. THIS IS COMPLETELY NORMAL FOR ANY FLAT PACK FURNITURE. DO NOT OVERTIGHTEN FIXINGS.

FOR CLEANING, YOU MAY USE A DAMP CLOTH (NOT WET). DO NOT USE POLISH, DETERGENT OR CHEMICAL CLEANERS.



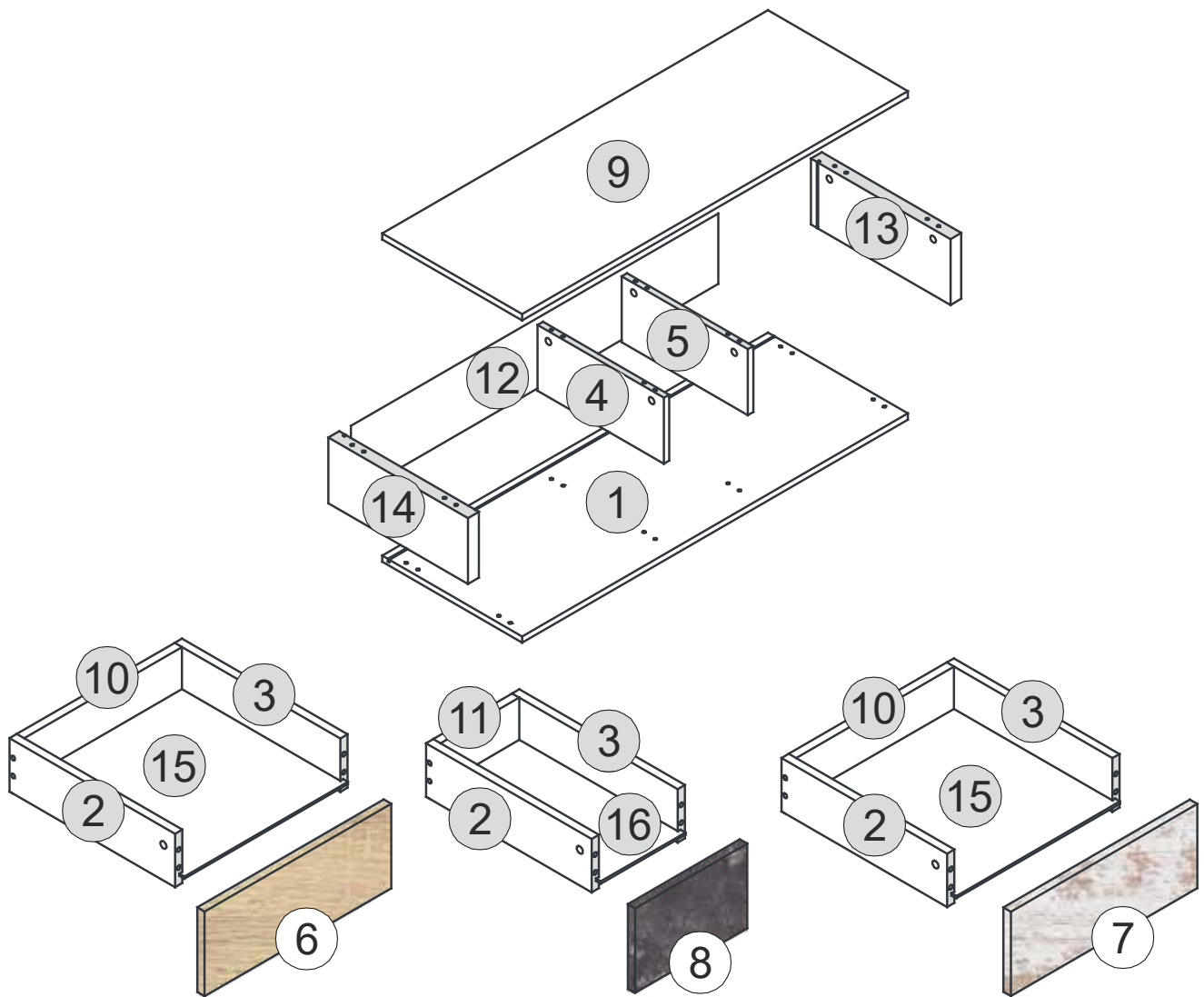











THIS SURFACE OF THIS ITEM IS NOT HEAT RESISTANT. ALWAYS USE A PLACE MAT UNDER HOT OR COLD ITEMS TO PREVENT MARKING.



PART LIST

Part Number	Part Code	Part Description	Quantity	Carton
1	S100-120-017-ZF1-01	Bottom Panel	1	1/1
2	S100-120-017-ZF1-02	Left Drawer Side	3	1/1
3	S100-120-017-ZF1-03	Right Drawer Side	3	1/1
4	S100-120-017-ZF1-04	Left Centre Panel	1	1/1
5	S100-120-017-ZF1-05	Right Centre Panel	1	1/1
6	S100-120-017-ZF1-06	Left Drawer Front	1	1/1
7	S100-120-017-ZF1-07	Right Drawer Front	1	1/1
8	S100-120-017-ZF1-08	Centre Drawer Front	1	1/1
9	S100-120-017-ZF1-09	Top Panel	1	1/1
10	S100-120-017-ZF1-10	Back Drawer Side	2	1/1
11	S100-120-017-ZF1-11	Centre Back Drawer Panel	1	1/1
12	S100-120-017-ZF1-12	Back Panel	1	1/1
13	S100-120-017-ZF1-13	Right Side Panel	1	1/1
14	S100-120-017-ZF1-14	Left Side Panel	1	1/1
15	S100-120-017-ZF1-15	Drawer Bottom	2	1/1
16	S100-120-017-ZF1-16	Centre Drawer Bottom	1	1/1

HARDWARE LIST

No.	Part Name		Qty	No.	Part Name		Qty
A	Wooden Dowel (6x25mm)		x22	H	Wooden Leg + Plastic Foot		x4
B	45mm Screw (4x45mm)		x8	I	14" Drawer Slide (0.9mm) W (vkt)		x3
C	38mm Screw (4x38mm)		x12	J	Handle+Screw T-4538 (4x20mm=1pc)		x1
D	14mm Screw (3.5x14mm)		x28	K	Handle+Screw Y-8238 (3x16mm=2pcs)		x1
E	Cam Bolt (8032T)		x14	L	Handle+Screw L-3510 (3x16mm=4pcs)		x1
F	Cam Nut (1512)		x14	M	Wall Fixings (4x20mm=1pc)		x1
G	Corner Support (AC 101)		x2	N	65mm Screw (4x65mm)		x4

TIPS FOR FITTINGS CAM-LOCKS

WHEN FITTING CAM NUT. ENSURE STARTING POSITION IS CORRECT BEFORE YOU INSERT CONNECTING CAM BOLT TURN CLOCKWISE UNTIL SECURE

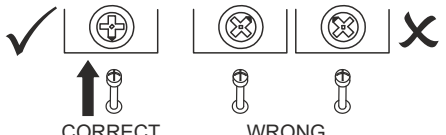

CORRECT **WRONG**

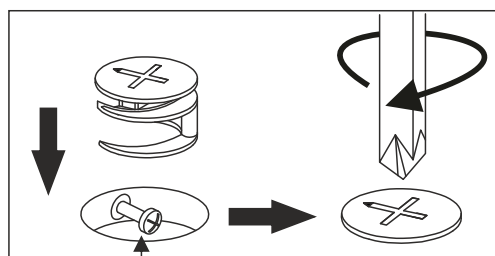

Cam bolt head needs to be in centre

CAMBOLT

Tighten until shoulder in flush with panel. Do not overtighten or undertighten (see example below)

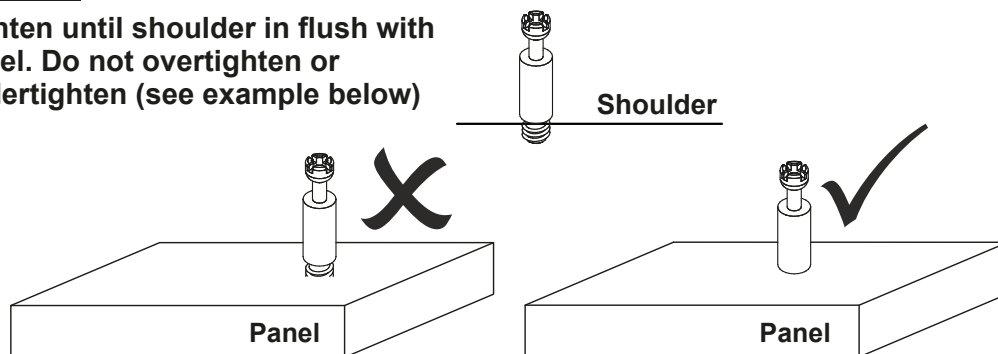

STEP 1

PARTS REQUIRED

9 - TOP PANEL x1

HARDWARE REQUIRED

E  08

TOOLS REQUIRED

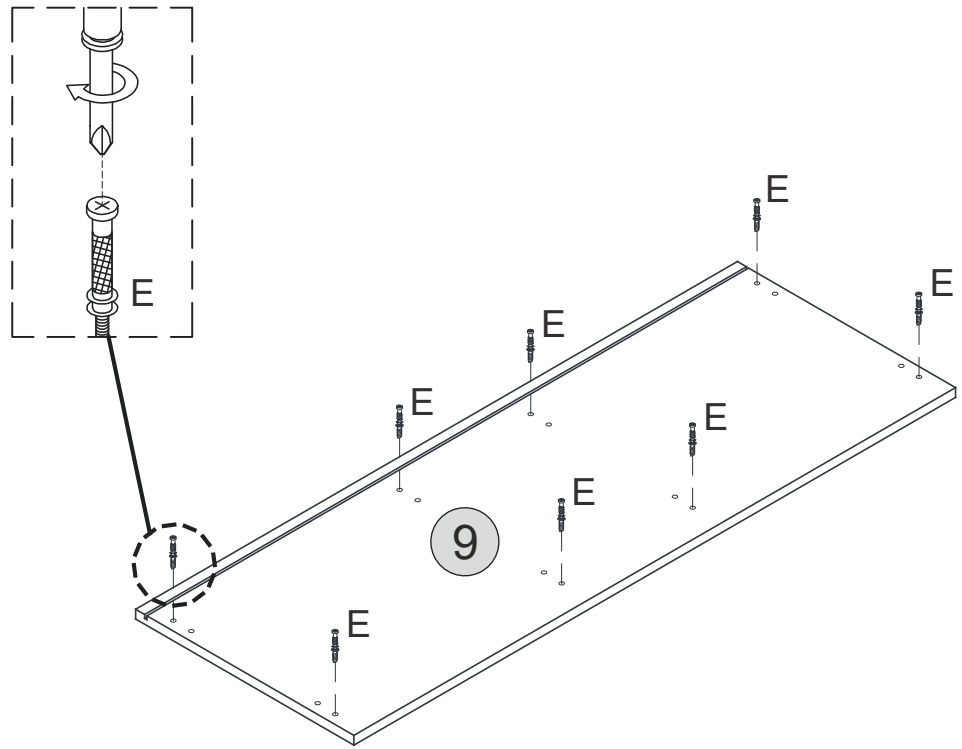
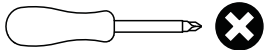

STEP 2

PARTS REQUIRED

13 - RIGHT SIDE PANEL x1

14 - LEFT SIDE PANEL x1

HARDWARE REQUIRED

A  08

D  3.5x14mm 04

I  02

TOOLS REQUIRED

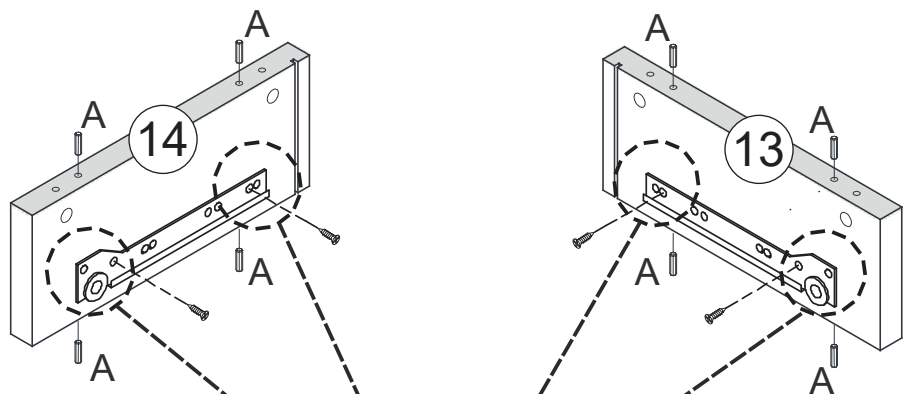
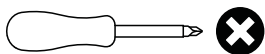

To Assemble the Drawer Slide, Please Follow Step as Below

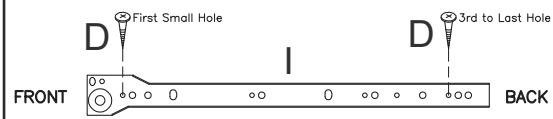

STEP 3

PARTS REQUIRED

4 - LEFT CENTRE PANEL x1

5 - RIGHT CENTRE PANEL x1

HARDWARE REQUIRED

A  08

D  3.5x14mm 04

I  02

TOOLS REQUIRED

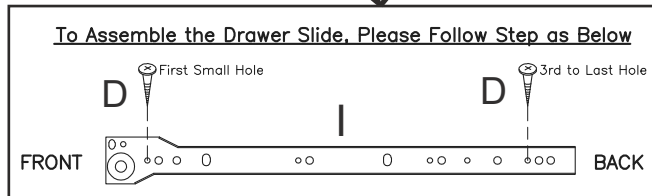
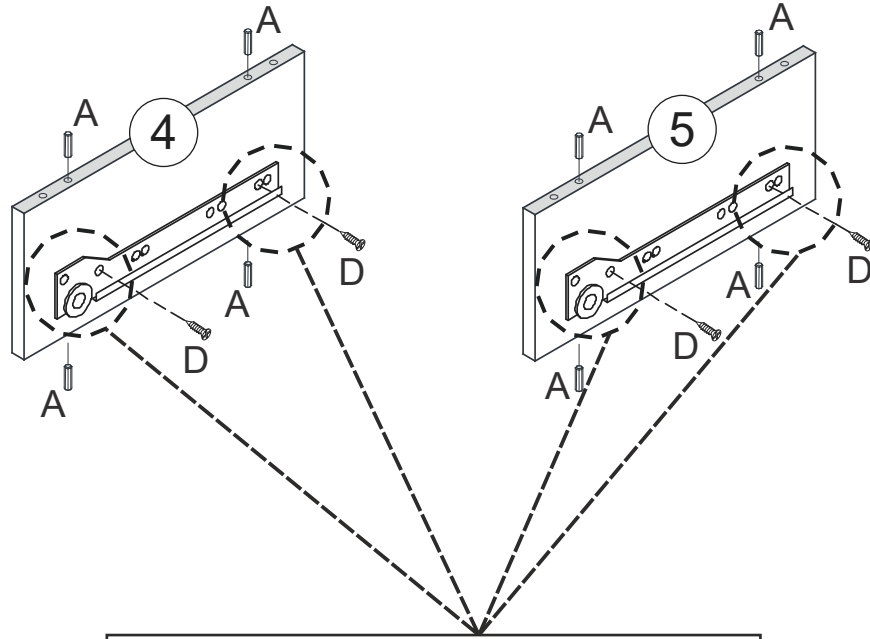
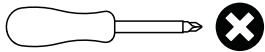

STEP 4

PARTS REQUIRED

4 - LEFT CENTRE PANEL x1

5 - RIGHT CENTRE PANEL x1

HARDWARE REQUIRED

D  3.5x14mm 04

I  02

TOOLS REQUIRED

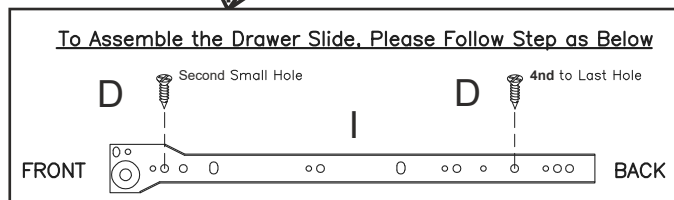
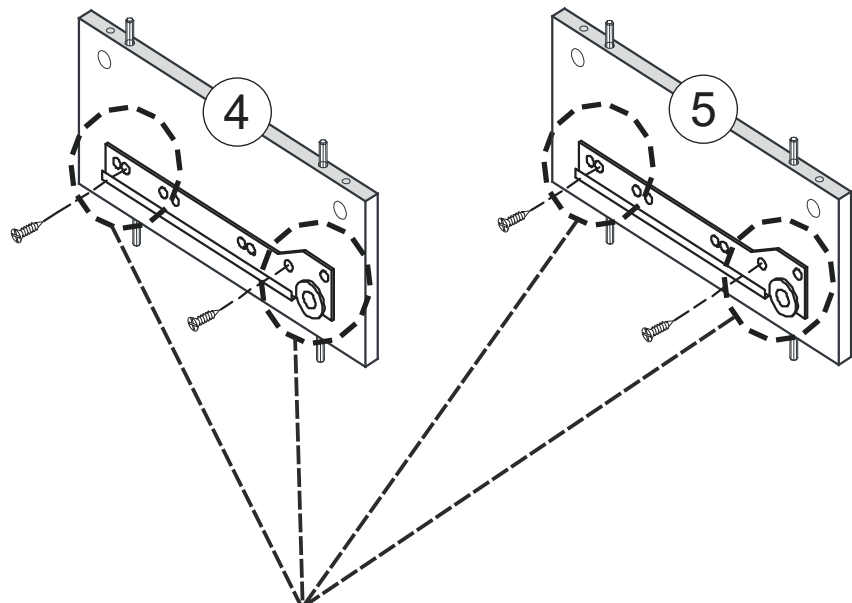
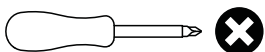

STEP 5

PARTS REQUIRED

4 - LEFT CENTRE PANEL x1

5 - RIGHT CENTRE PANEL x1

9 - TOP PANEL x1

13 - RIGHT SIDE PANEL x1

14 - LEFT SIDE PANEL x1

HARDWARE REQUIRED

F  08

TOOLS REQUIRED

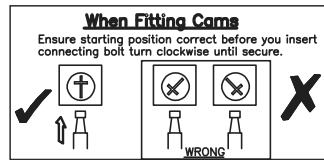
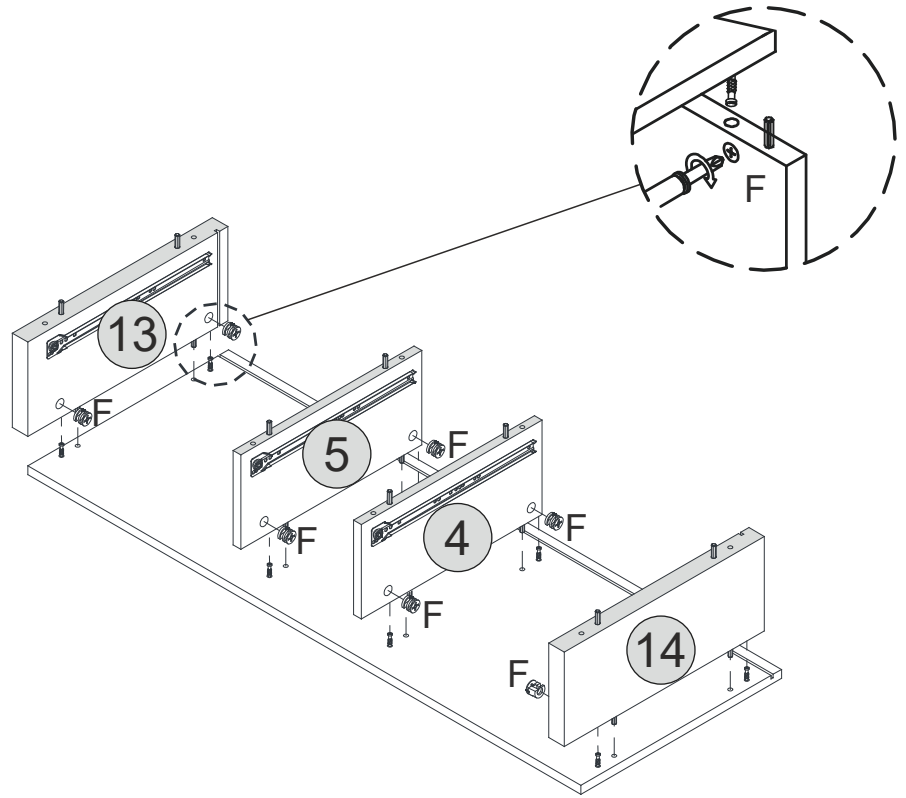
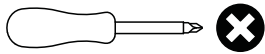

STEP 6

PARTS REQUIRED

12 - BACK PANEL x1

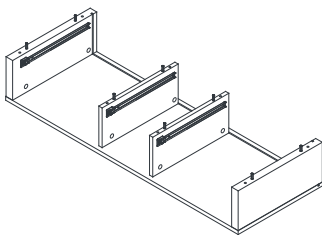

HARDWARE REQUIRED

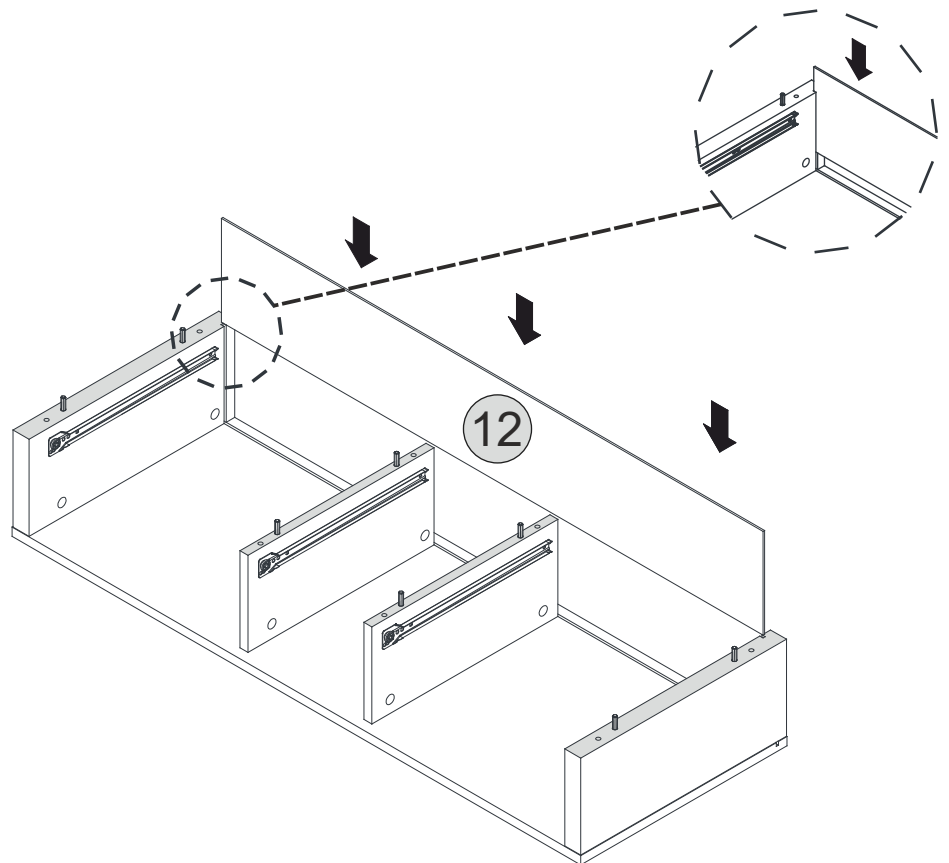

STEP 7

PARTS REQUIRED

1 - BOTTOM PANEL x1

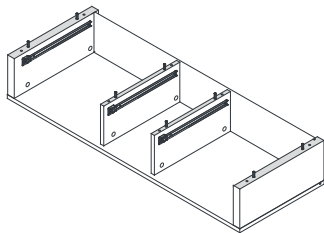

HARDWARE REQUIRED

B  08
4x45mm

TOOLS REQUIRED

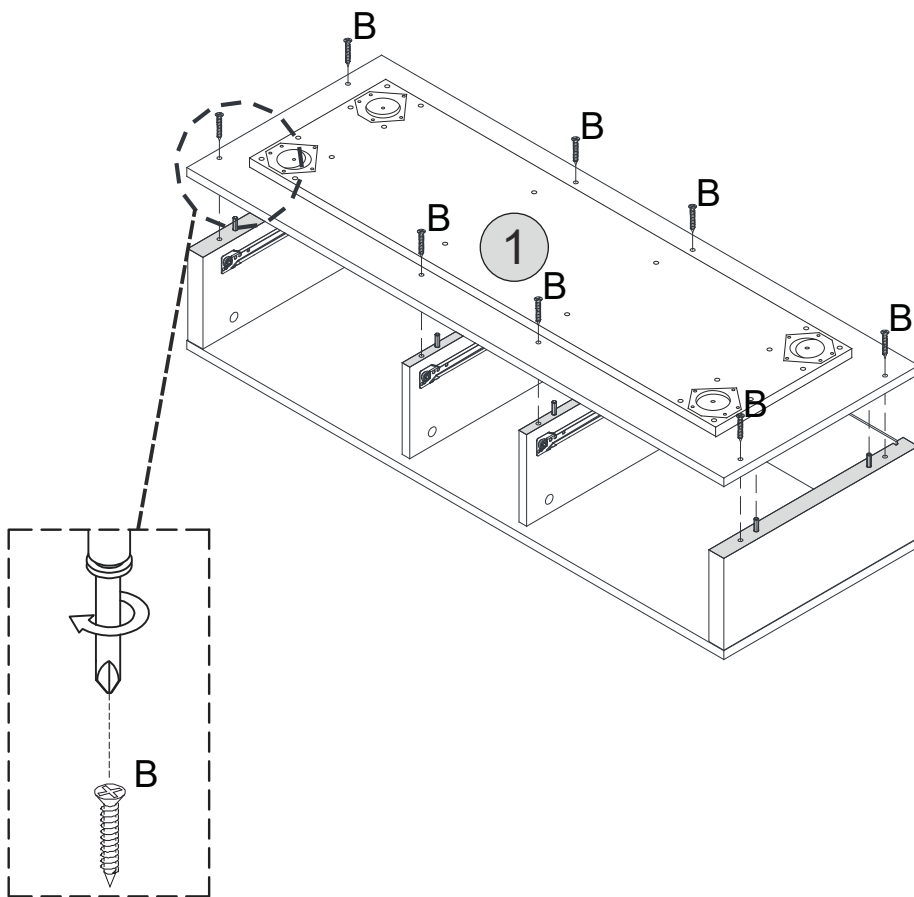
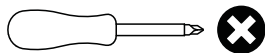

STEP 8

PARTS REQUIRED

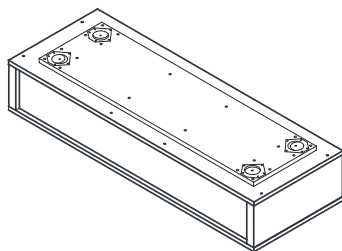

HARDWARE REQUIRED

D  04
3.5x14mm

G  02

N  04
4x65mm

TOOLS REQUIRED

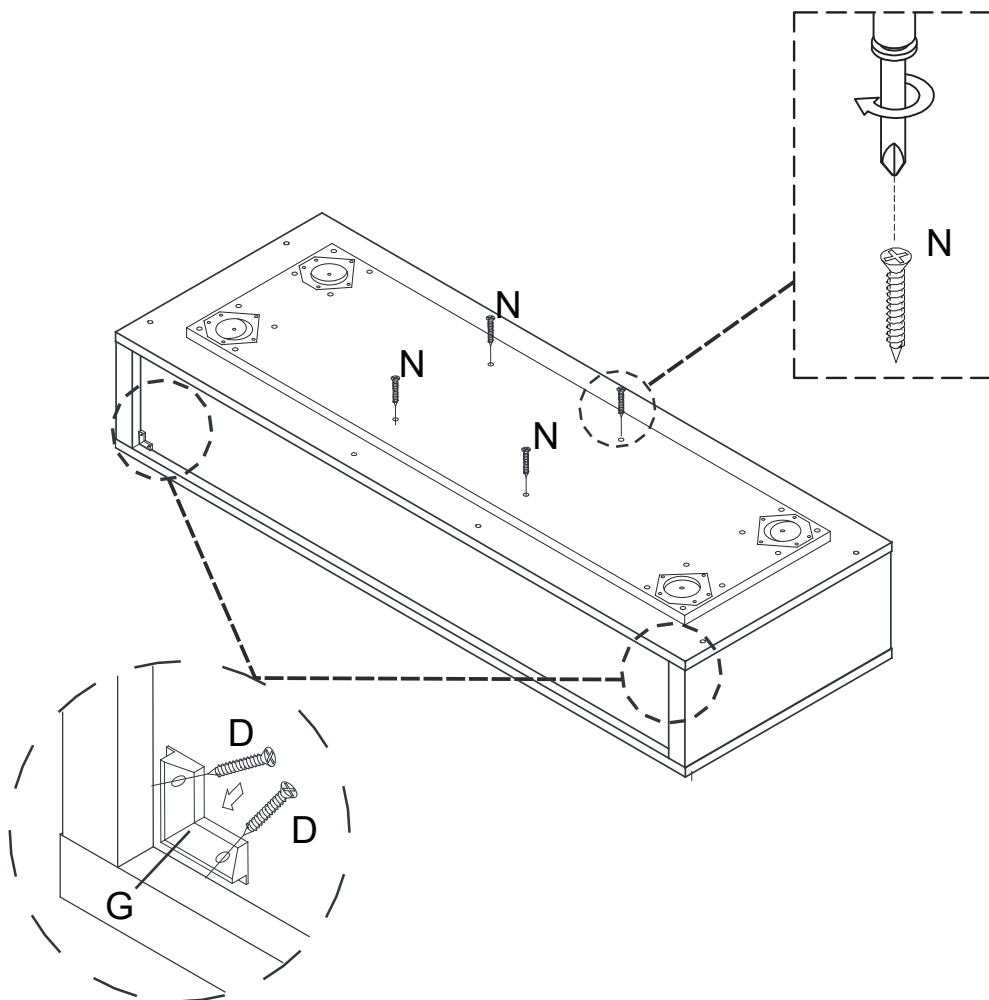
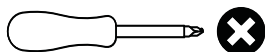

STEP 9

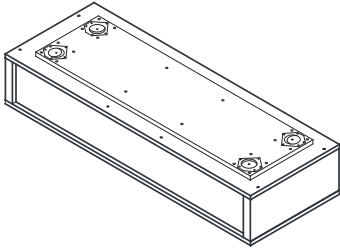

HARDWARE REQUIRED



TOOLS REQUIRED

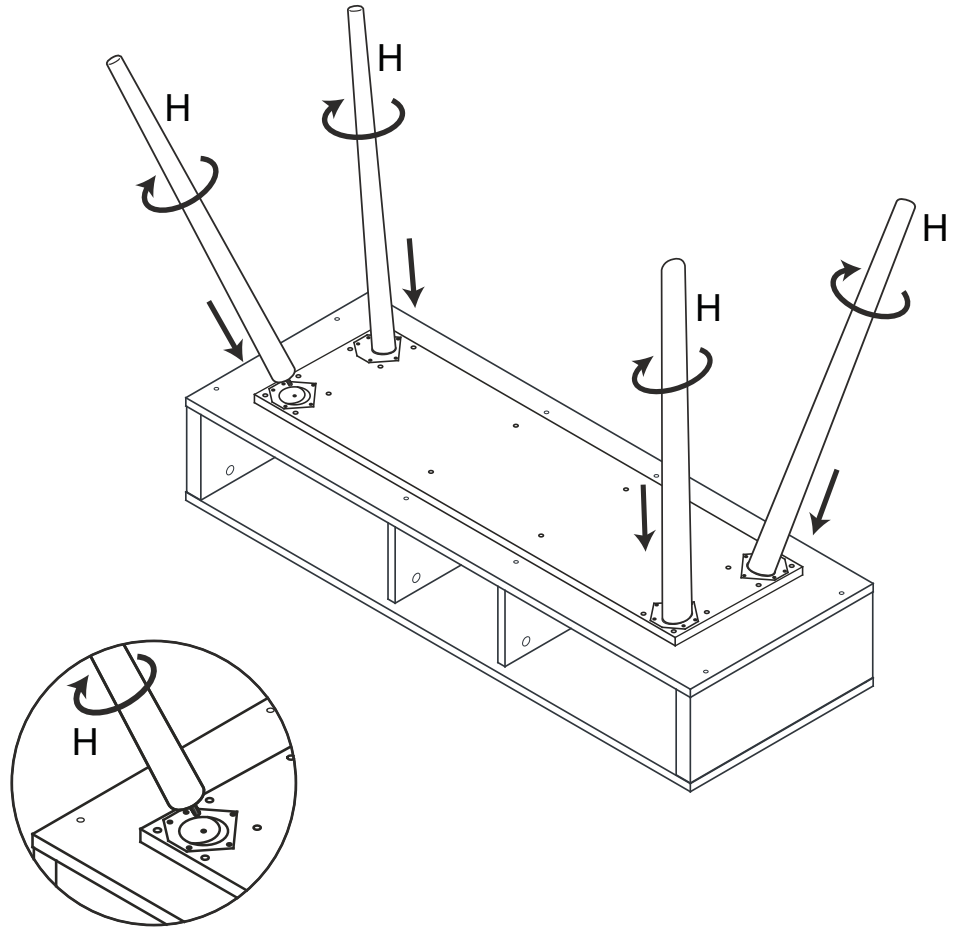
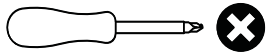

STEP 10

PARTS REQUIRED

- | | |
|-----------------------|----|
| 2 - LEFT DRAWER SIDE | x1 |
| 3 - RIGHT DRAWER SIDE | x1 |
| 6 - LEFT DRAWER FRONT | x1 |

HARDWARE REQUIRED

- | | | |
|---|--|----|
| A | | 02 |
| E | | 02 |
| F | | 02 |

TOOLS REQUIRED

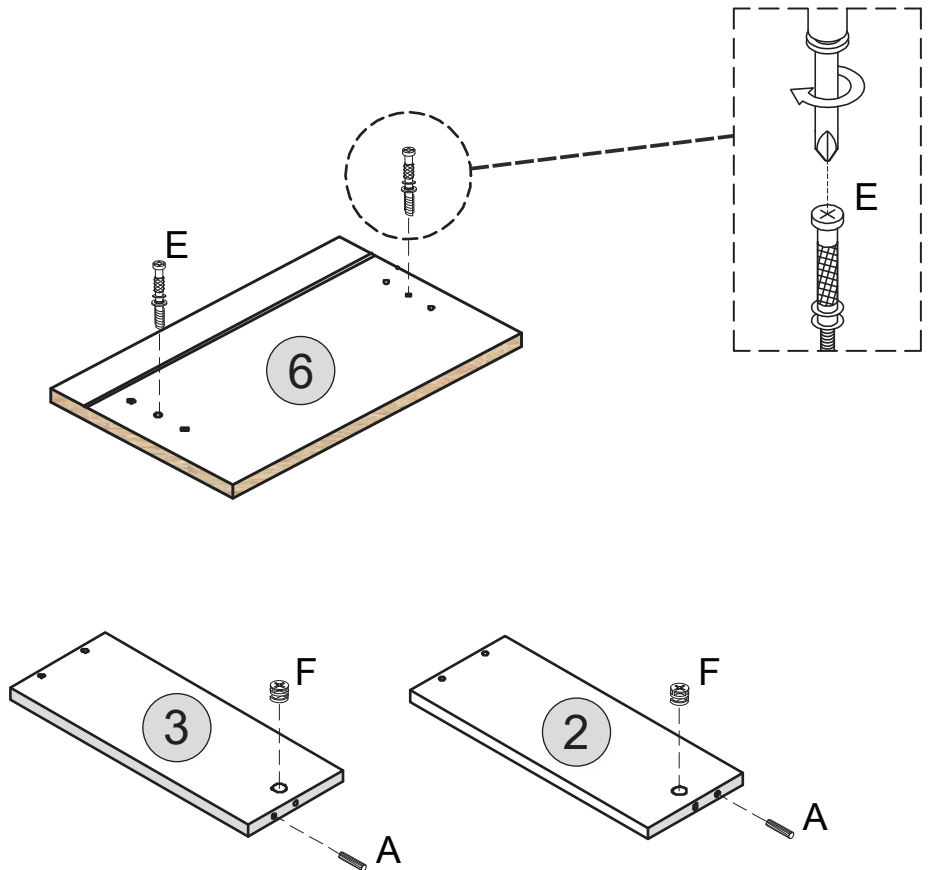
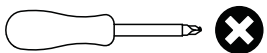

STEP 11

PARTS REQUIRED

2 - LEFT DRAWER SIDE	x1
3 - RIGHT DRAWER SIDE	x1
6 - LEFT DRAWER FRONT	x1
10 - BACK DRAWER SIDE	x1
15 - DRAWER BOTTOM	x1

HARDWARE REQUIRED

C		04
---	---	----

TOOLS REQUIRED

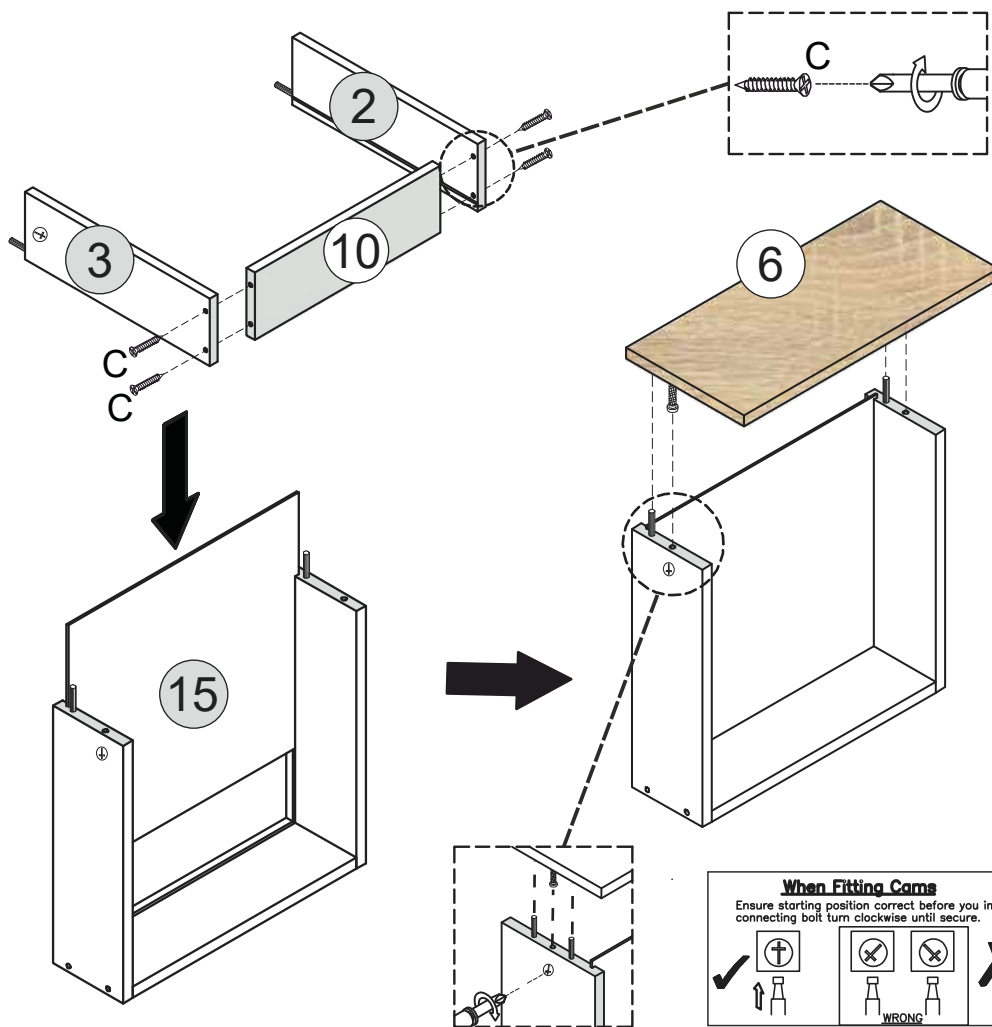
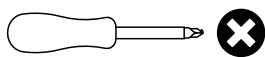

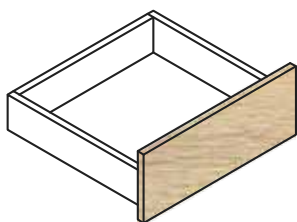

STEP 12

PARTS REQUIRED



HARDWARE REQUIRED

D		04
I		02
K		01

TOOLS REQUIRED

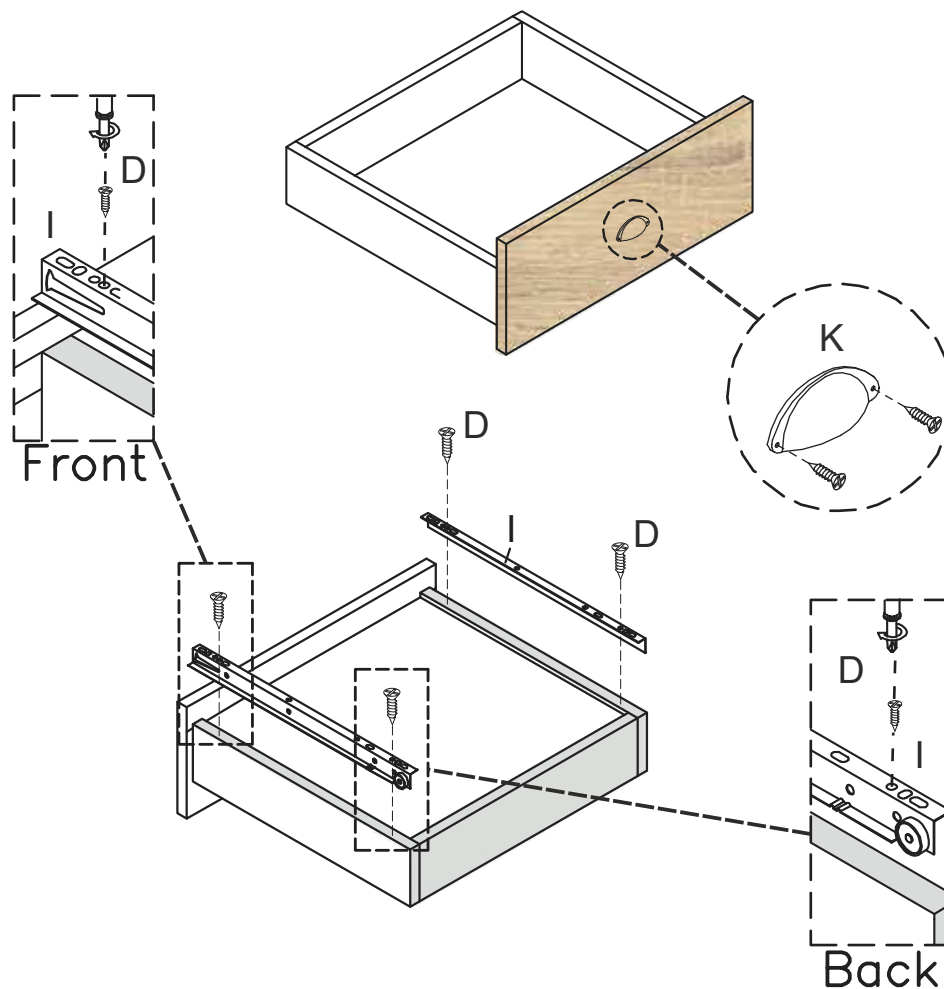
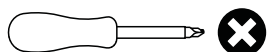



STEP 13

PARTS REQUIRED

2 - LEFT DRAWER SIDE	x1
3 - RIGHT DRAWER SIDE	x1
7 - RIGHT DRAWER FRONT	x1

HARDWARE REQUIRED

A		02
E		02
F		02

TOOLS REQUIRED

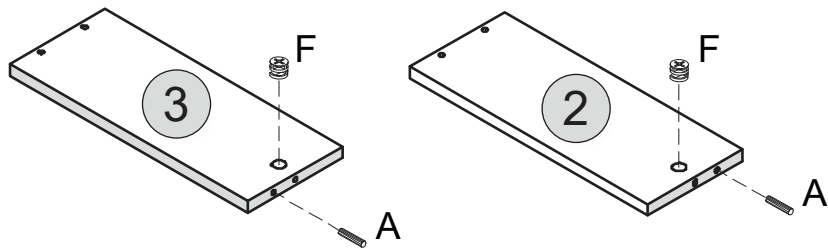
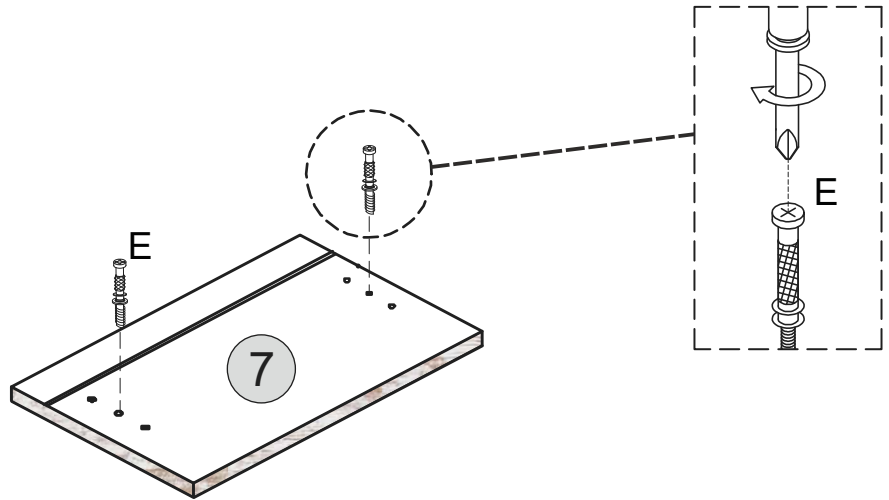
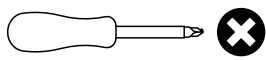

STEP 14

PARTS REQUIRED

2 - LEFT DRAWER SIDE	x1
3 - RIGHT DRAWER SIDE	x1
7 - RIGHT DRAWER FRONT	x1
10 - BACK DRAWER SIDE	x1
15 - DRAWER BOTTOM	x1

HARDWARE REQUIRED

C		04
---	---	----

TOOLS REQUIRED

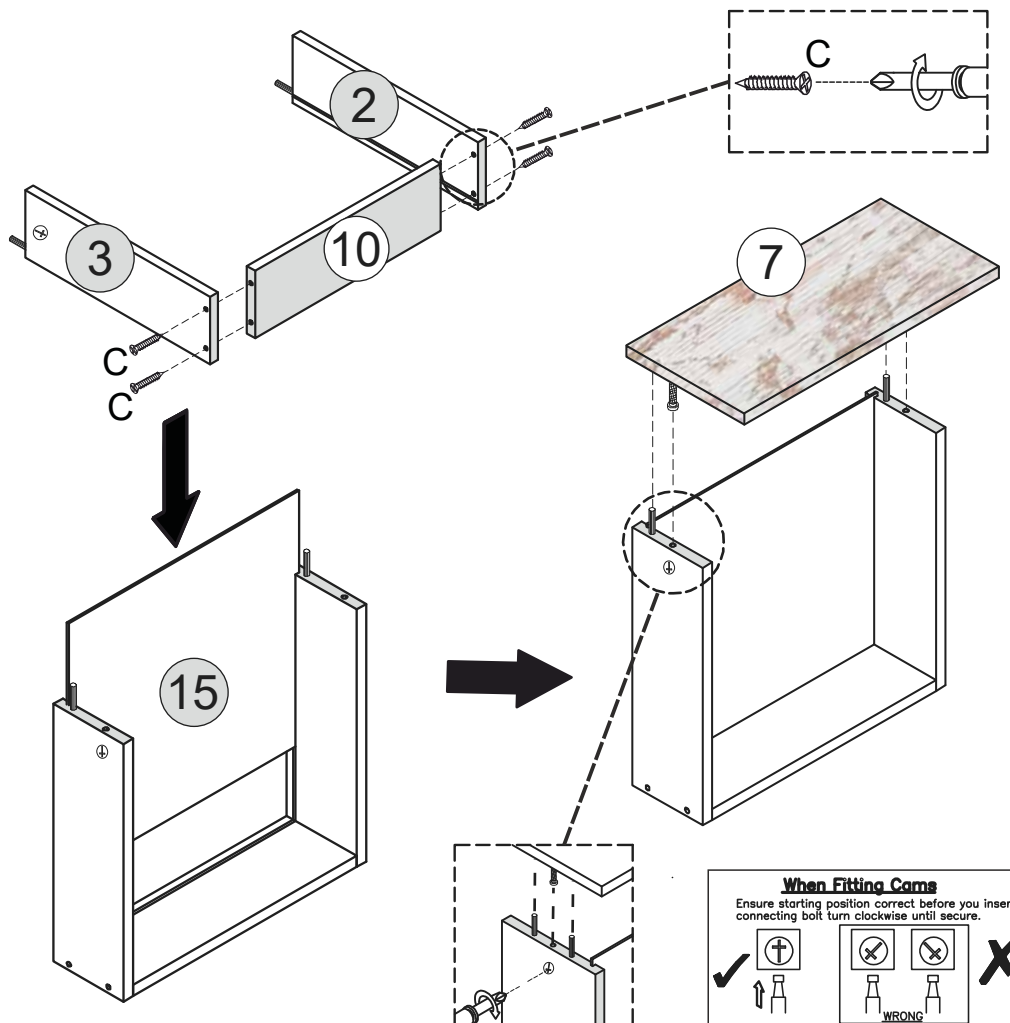
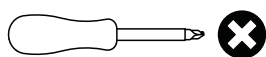



When Fitting Cams
Ensure starting position correct before you insert connecting bolt turn clockwise until secure.

STEP 15

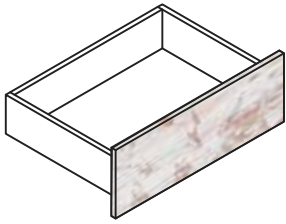
PARTS REQUIRED



HARDWARE REQUIRED

D	 3.5x16mm	04
I		02
J		01

TOOLS REQUIRED

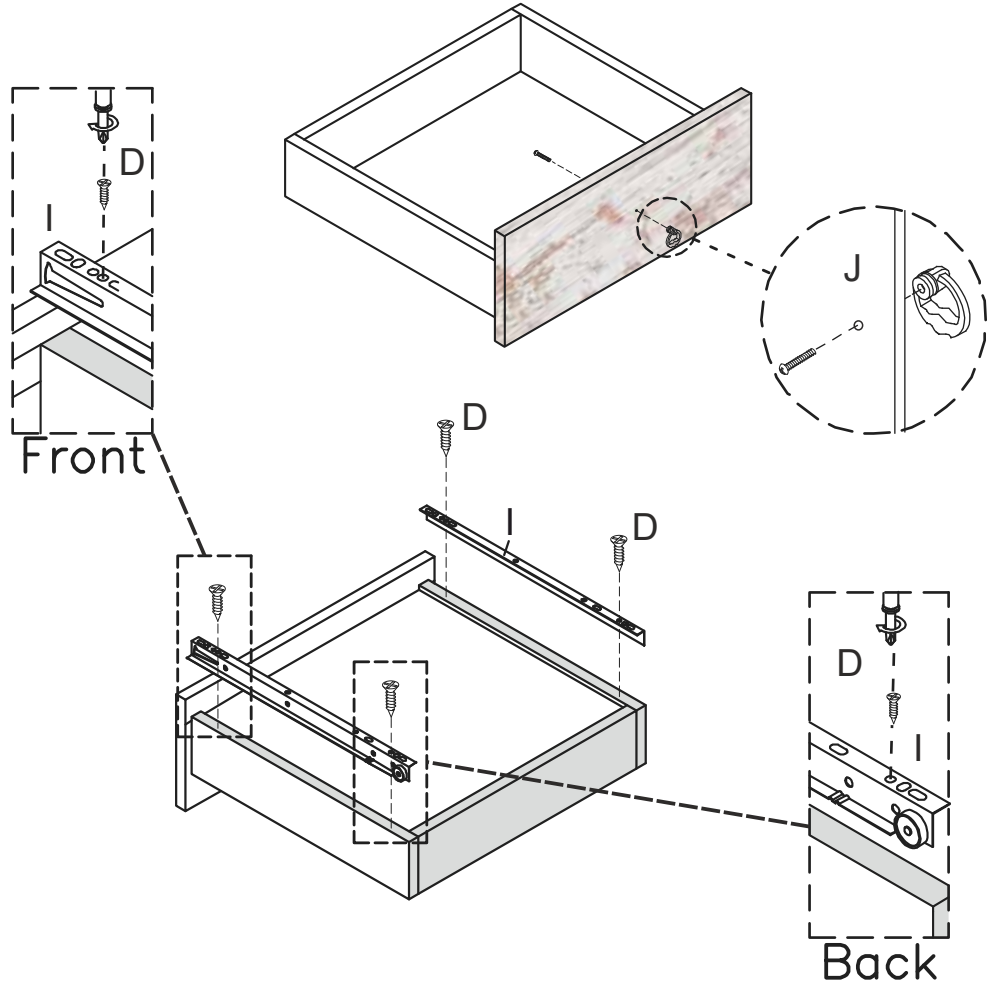
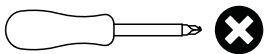



STEP 16

PARTS REQUIRED

2 - LEFT DRAWER SIDE	x1
3 - RIGHT DRAWER SIDE	x1
8 - CENTRE DRAWER FRONT	x1

HARDWARE REQUIRED

A		02
E		02
F		02

TOOLS REQUIRED

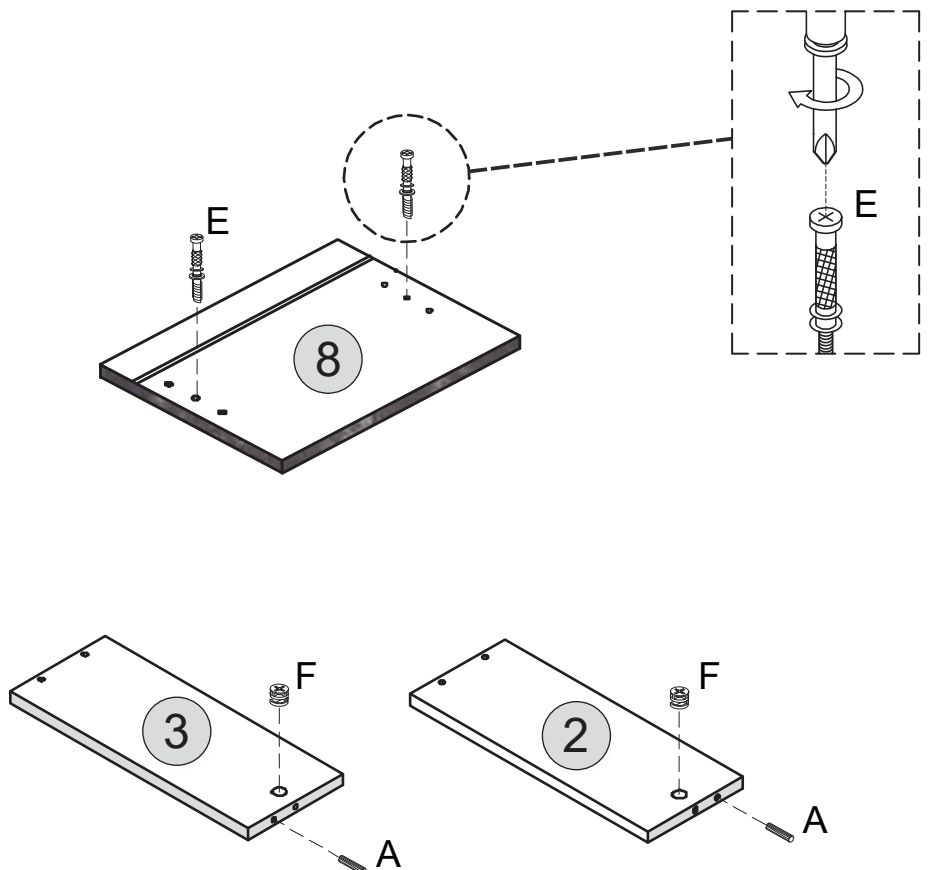
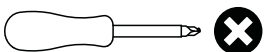

STEP 17

PARTS REQUIRED

- 2 - LEFT DRAWER SIDE x1
- 3 - RIGHT DRAWER SIDE x1
- 8 - CENTRE DRAWER FRONT x1
- 11 - CENTRE BACK DRAWER PANEL x1
- 15 - CENTRE DRAWER BOTTOM x1

HARDWARE REQUIRED

- C  04

TOOLS REQUIRED

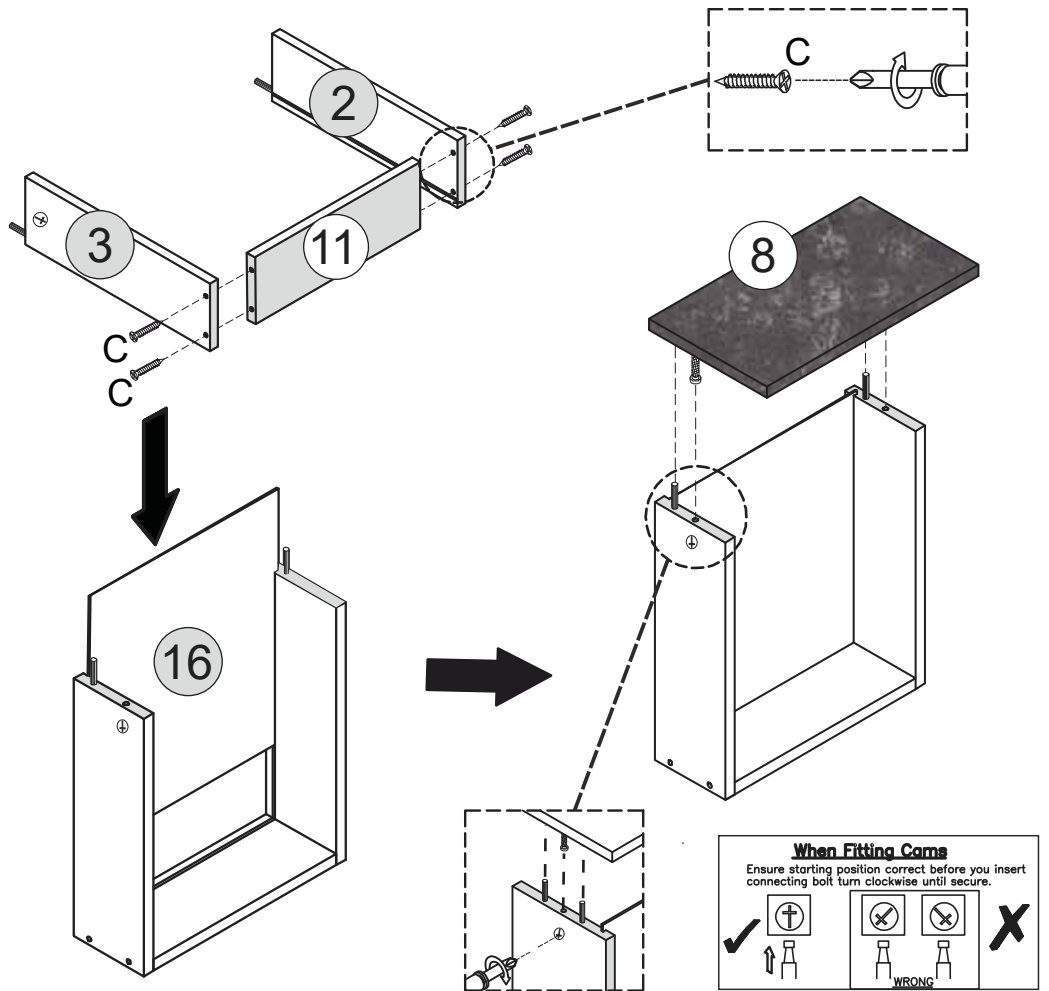
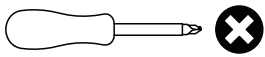

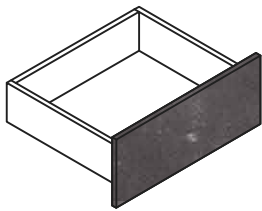

STEP 18

PARTS REQUIRED



HARDWARE REQUIRED

- D  04
- I  02
- L  01

TOOLS REQUIRED

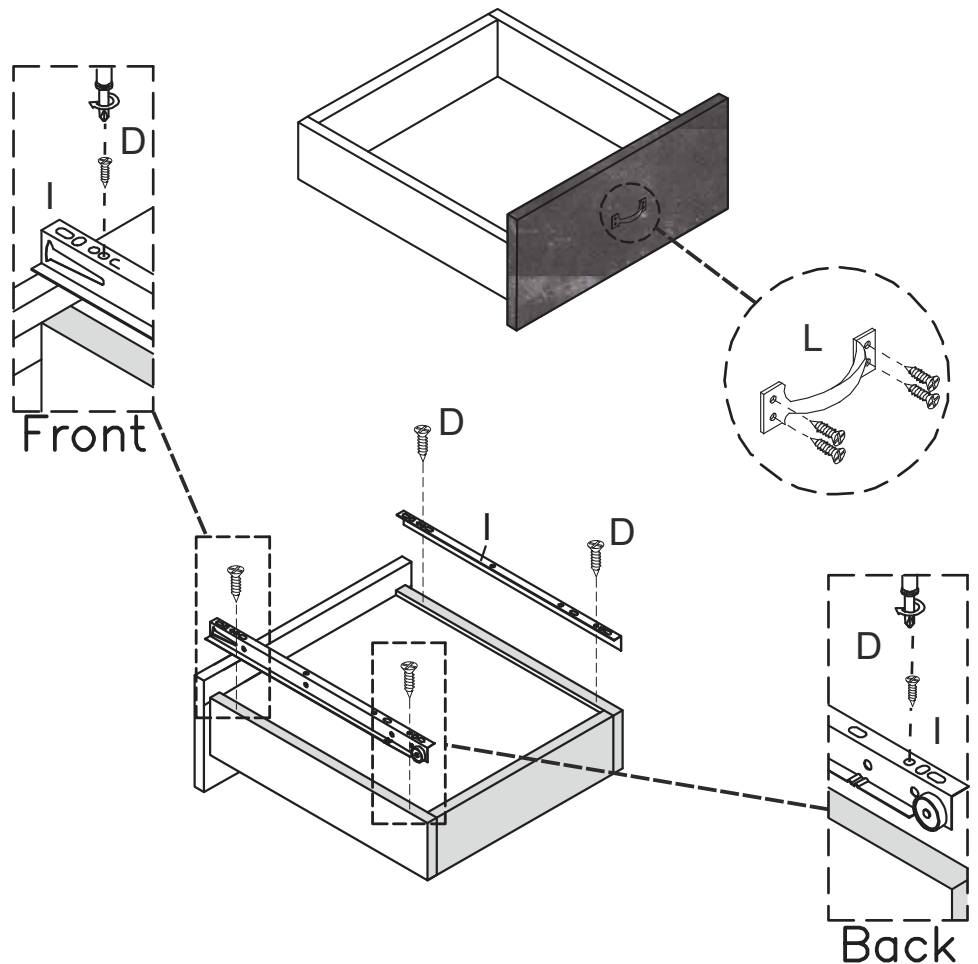
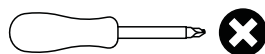

STEP 19

PARTS REQUIRED

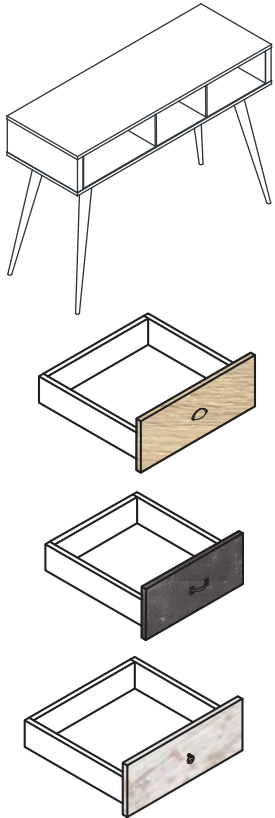

STEP 20

PARTS REQUIRED



HARDWARE REQUIRED



TOOLS REQUIRED

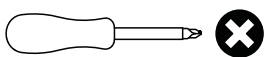

WARNING

Serious or fatal injuries can occur from furniture tipping over. To prevent the furniture from tipping over we recommend that it is permanently fixed to the wall.

Wall fixings are not supplied with this product as different wall materials require different types of fixing devices. Please make sure you use fixings suitable for the walls in your home.

