

# NEVADA BLANKET BOX

## ASSEMBLY INSTRUCTIONS

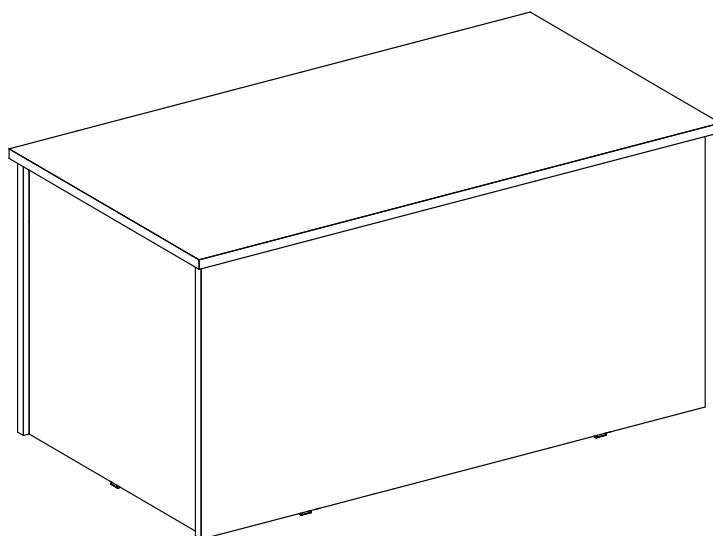

### **IMPORTANT**

### **FOR DOMESTIC USE ONLY**

**PLEASE READ BEFORE YOU CONTINUE FURTHER**

## **CARE AND MAINTENANCE**

After unpacking this product please keep the original packaging in case it needs to be returned for any reason.



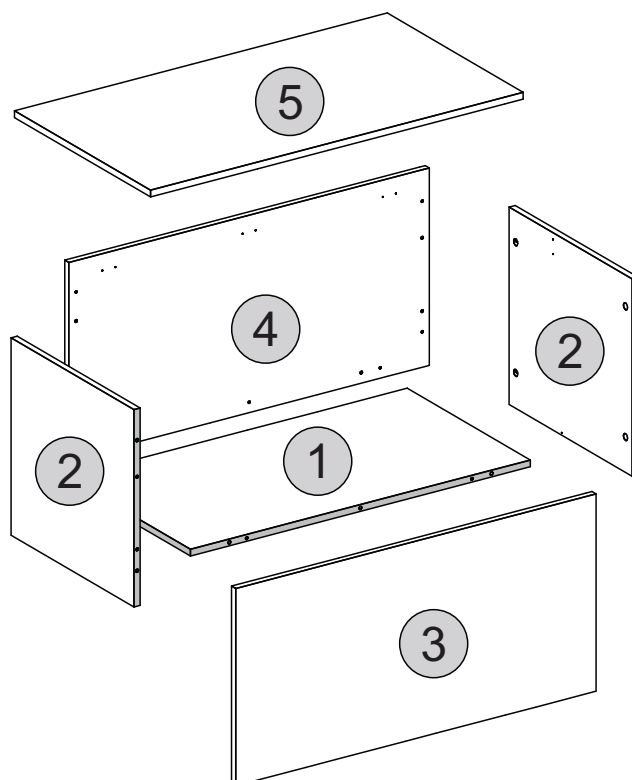
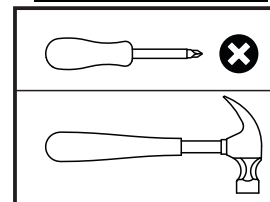



- Please ensure all fittings and parts are present before commencing with assembly.
- Never drag or push products as this could cause damage to the joints making it inferior.
- We strongly recommend that you keep children away from your work area.
- We recommend that you lay a blanket or sheet on the floor to avoid damage to both your floor and the product.
- Assemble this product as close to its final position as possible.
- Do not place this product next to a radiator or in direct sunlight.
- Do not drag or push items across your high gloss furniture as this may cause the surface to scratch
- Wood is a natural product and may expand if subjected to damp and may shrink or crack if subjected to heat. Therefore it is recommended that room temperature is maintained, with no sudden temperature fluctuations.
- Make sure any spillage is wiped off immediately.
- Do not place hot or chilled items directly on to the surface, use a place mat or marking will occur.
- For general cleaning use a soft cotton or micro fibre cloth, and do not use detergents of any kind.
- From time to time it may be necessary to tighten fittings, regular inspections should be carried out.
- Do not place on a wet or damp floor as staining may occur to your floor.

**TOOLS REQUIRED*****Please Note:***

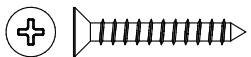
The below parts have all been stamped with the part number to help identify them during assembly.

<b>Part Number</b>	<b>Part Description</b>	<b>Quantity</b>	<b>Carton</b>
1	Base Panel	1	1/1
2	Side Panel	2	1/1
3	Front Panel	1	1/1
4	Back Panel	1	1/1
5	Top Panel	1	1/1

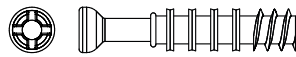
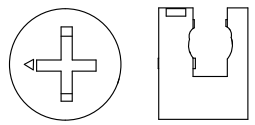
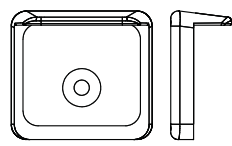
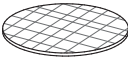
## FITTINGS LIST

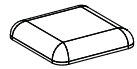
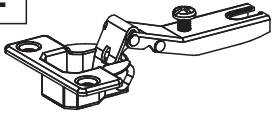
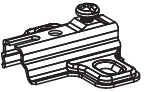
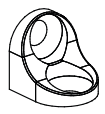
<p><b>A</b></p>  <p>Flat Head Screw Ø3,5 x 20mm (5x) <small>+/1</small></p>	<p><b>B</b></p>  <p>Flat Head Screw Ø4,0 x 14mm (18x) <small>+/2</small></p>	<p><b>C</b></p>  <p>Opening Limiter 250mm (1x)</p>	
<p><b>D</b></p>  <p>Dowel Ø6,0 x 30mm (12x) <small>+/2</small></p>	<p><b>E</b></p>  <p>Nail 10 x 10 (6x) <small>+/2</small></p>	<p><b>F</b></p>  <p>Cam Bolt (14x) <small>+/2</small></p>	<p><b>G</b></p>  <p>Cam Nut (14x) <small>+/2</small></p>
<p><b>H</b></p>  <p>Plastic Foot (6x) <small>+/1</small></p>	<p><b>I</b></p>  <p>Hole Plugs (8x) <small>+/2</small></p>	<p><b>J</b></p>  <p>Glue (1x) <small>+/2</small></p>	<p><b>K</b></p>  <p>Sticker Door Support (3x) <small>+/1</small></p>
<p><b>L</b></p>  <p>Hinge (3x)</p>	<p><b>M</b></p>  <p>Hinge Plate (3x)</p>	<p><b>N</b></p>  <p>Metallic Support (2x) <small>+/1</small></p>	

## TIPS FOR FITTINGS CAM-LOCKS

WHEN FITTING CAM NUT, ENSURE STARTING POSITION IS CORRECT BEFORE YOU INSERT CONNECTING CAM BOLT TURN CLOCKWISE UNTIL SECURE

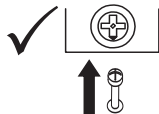

↑  
**CORRECT**

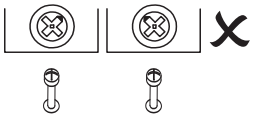

↑  
**WRONG**

Cam bolt head needs to be in centre

### CAMBOLT

Tighten until shoulder in flush with panel. Do not overtighten or undertighten (see example beside)

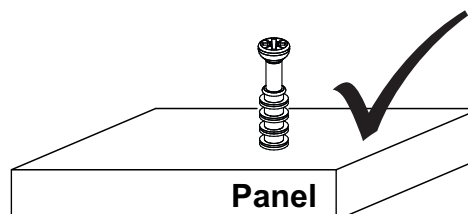
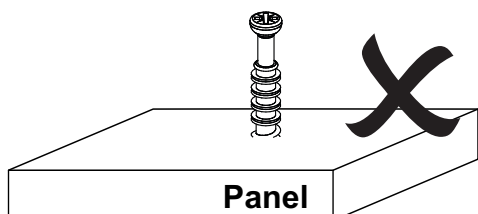
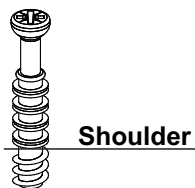





# STEP 1

## PARTS REQUIRED

3 - FRONT PANEL x1

## HARDWARE REQUIRED

- E  10 x 10 02
- F  Cam Bolt 07
- H  02
- K  Sticker Door Support 03

## TOOLS REQUIRED

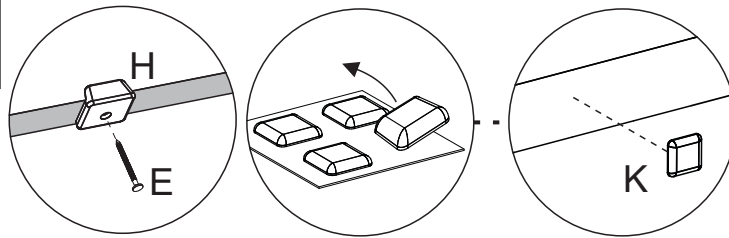
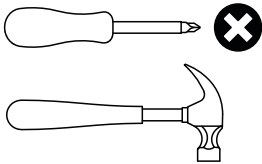

Detail 4

Detail 2

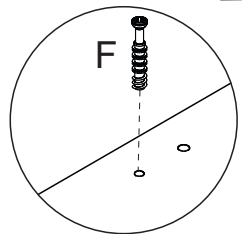
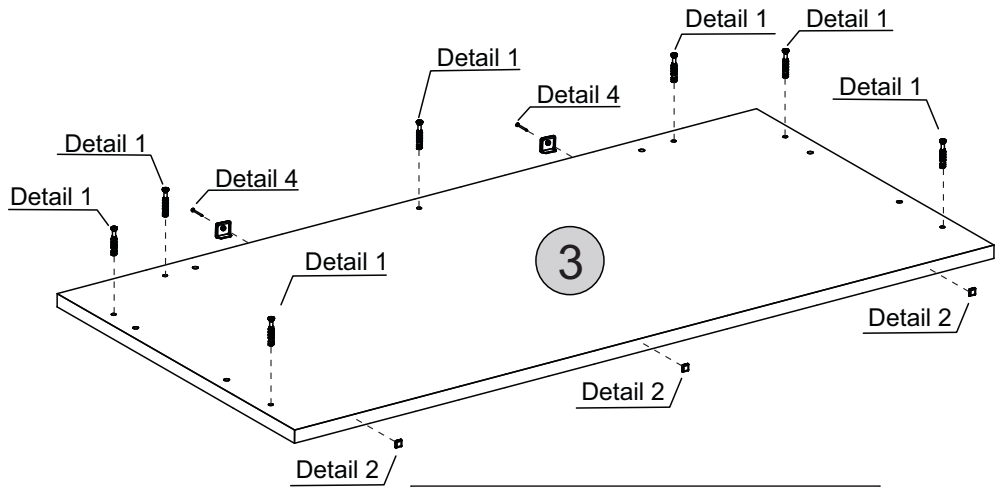

Detail 1

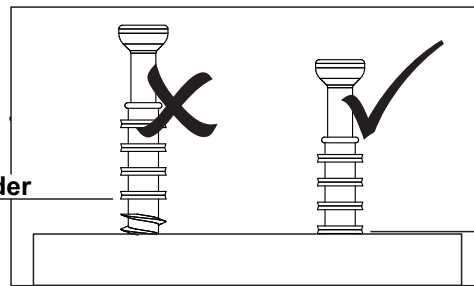

Shoulder





Shoulder

# STEP 2

## PARTS REQUIRED

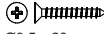
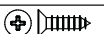
4 - BACK PANEL x1

## HARDWARE REQUIRED

- A  Ø3.5 x 20mm 03
- B  Ø4.0 x 14mm 06
- E  10 x 10 02
- F  Cam Bolt 07
- H  02
- M  03

## TOOLS REQUIRED

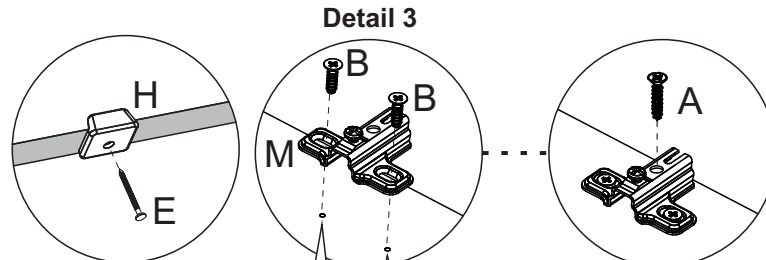
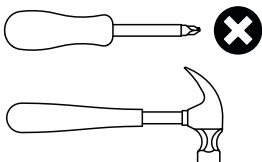

Detail 4

Please note:  
Pre-marked  
Holes

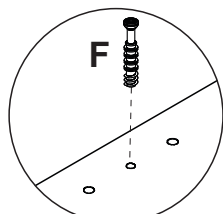
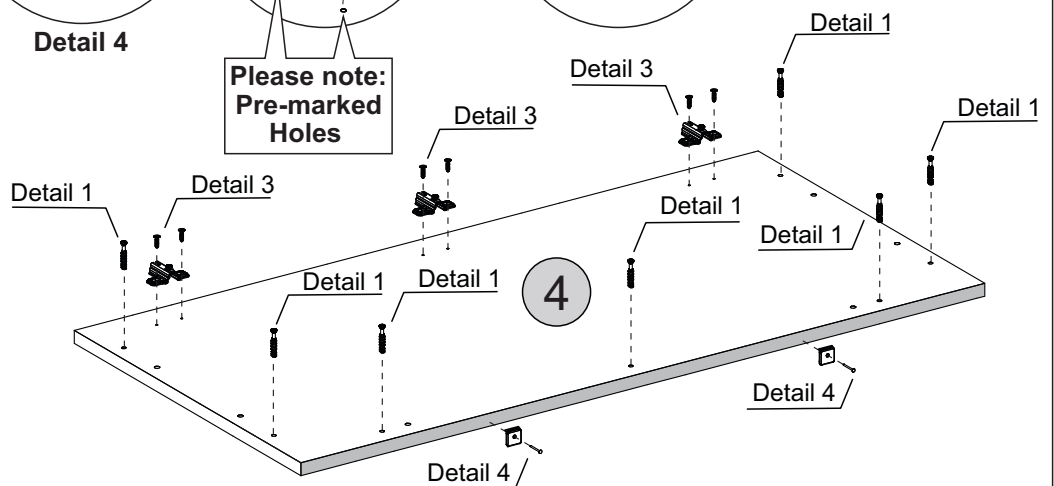

Detail 1

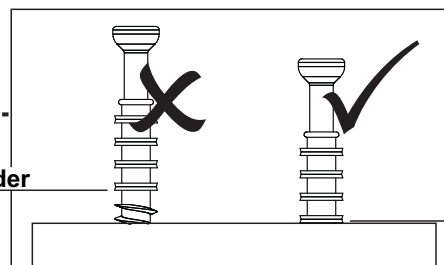

Shoulder







Shoulder

# STEP 3

## PARTS REQUIRED

2 - SIDE PANEL x2

## HARDWARE REQUIRED

- B  02  
Ø4,0 x 14mm
- E  02
- D  08  
Ø6,0 x 30mm
- H  02
- J  01
- N  02

## TOOLS REQUIRED

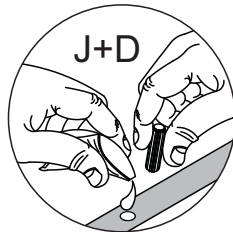
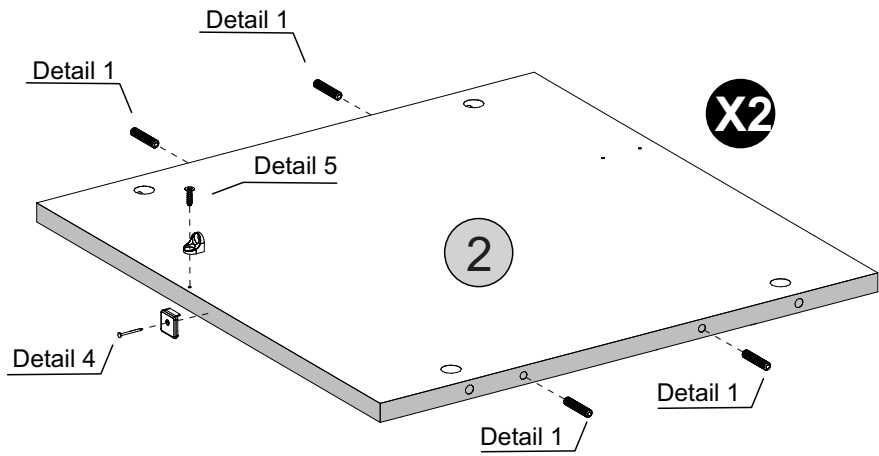
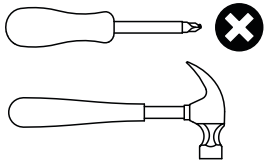

Detail 1

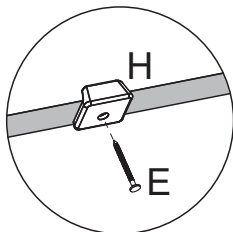

Detail 4

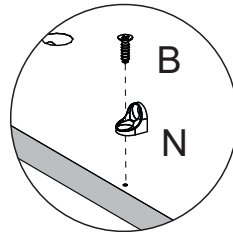



Detail 5

# STEP 4

## PARTS REQUIRED

1 - BASE PANEL x1

## HARDWARE REQUIRED

- D  04  
Ø6,0 x 30mm
- J  01

## TOOLS REQUIRED

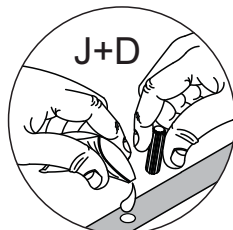
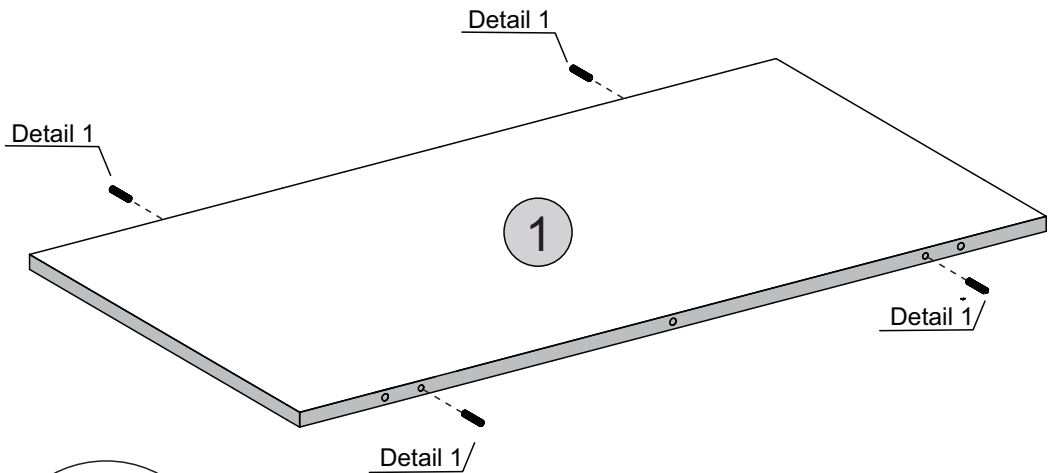

Detail 1

# STEP 5

## PARTS REQUIRED

5 - TOP PANEL x1

## HARDWARE REQUIRED

B  06  
Ø4,0 x 14mm

L  03

## TOOLS REQUIRED

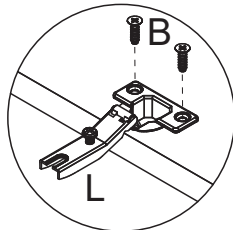
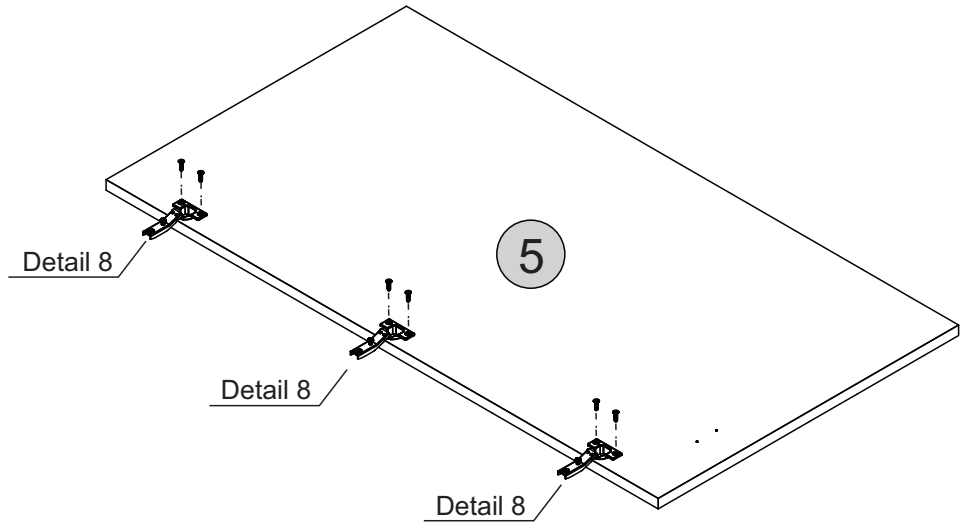
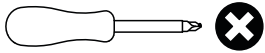

Detail 8

# STEP 6

## PARTS REQUIRED

1 - BASE PANEL x1

4 - BACK PANEL x1

## HARDWARE REQUIRED

G  03

J  01

## TOOLS REQUIRED

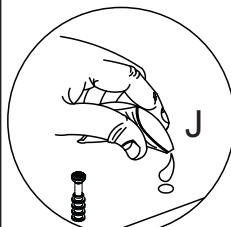
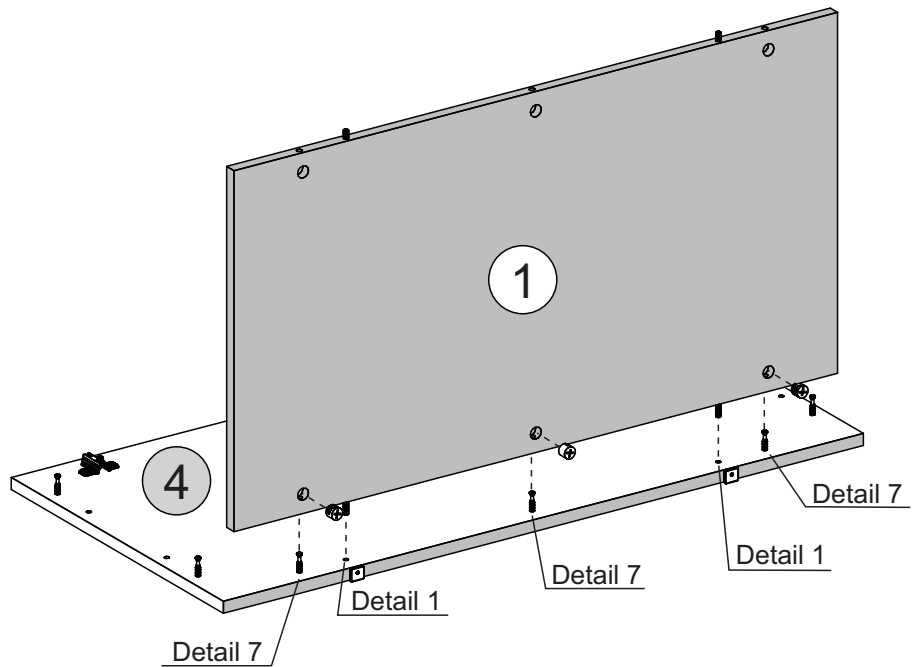
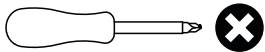

Detail 1

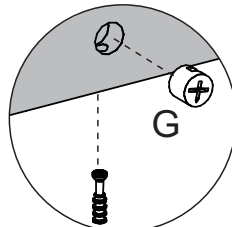

Detail 7

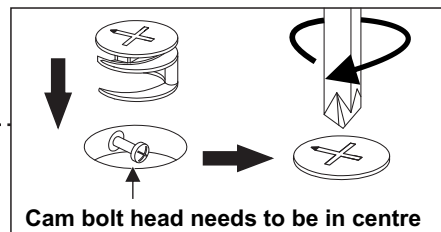

# STEP 7

## PARTS REQUIRED

2 - SIDE PANEL x1

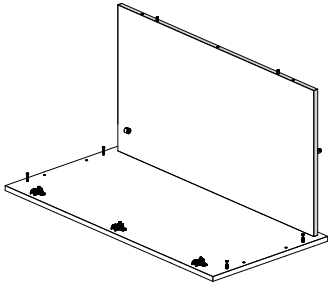

## HARDWARE REQUIRED

G  02

J  01

## TOOLS REQUIRED

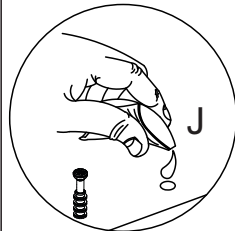
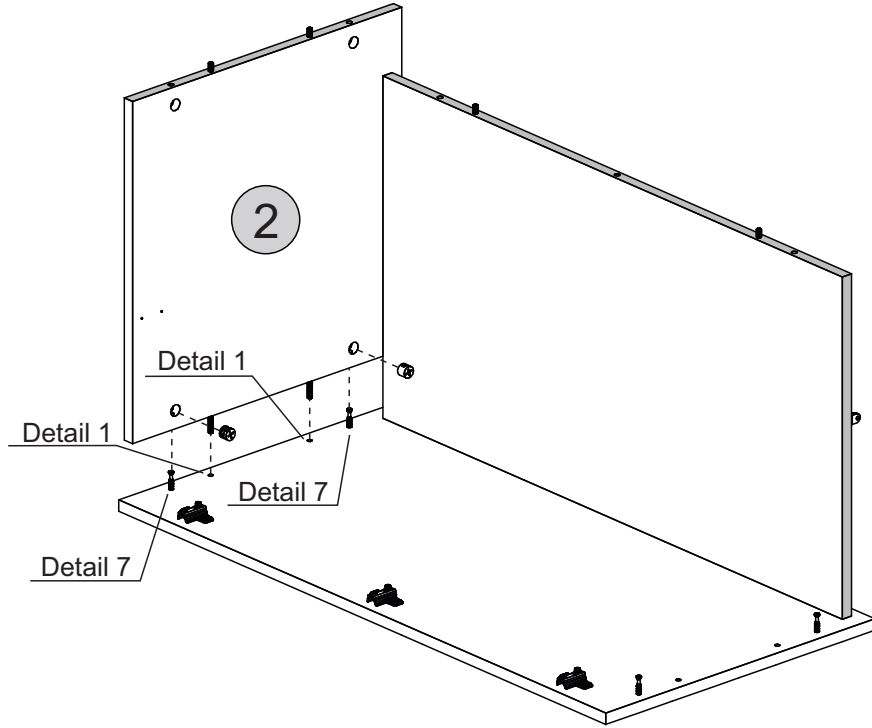
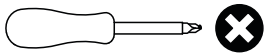

Detail 1

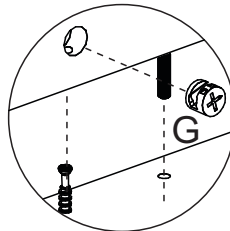

Detail 7

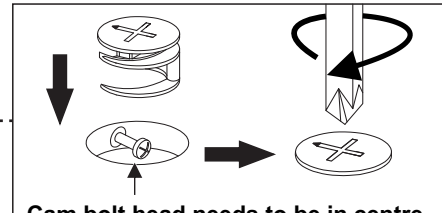

Cam bolt head needs to be in centre

# STEP 8

## PARTS REQUIRED

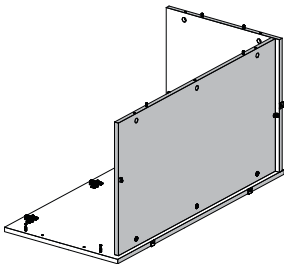

## HARDWARE REQUIRED

B  01  
Ø4.0 x 14mm

## TOOLS REQUIRED

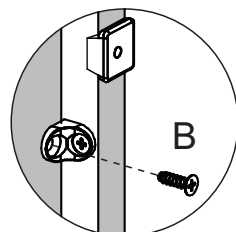
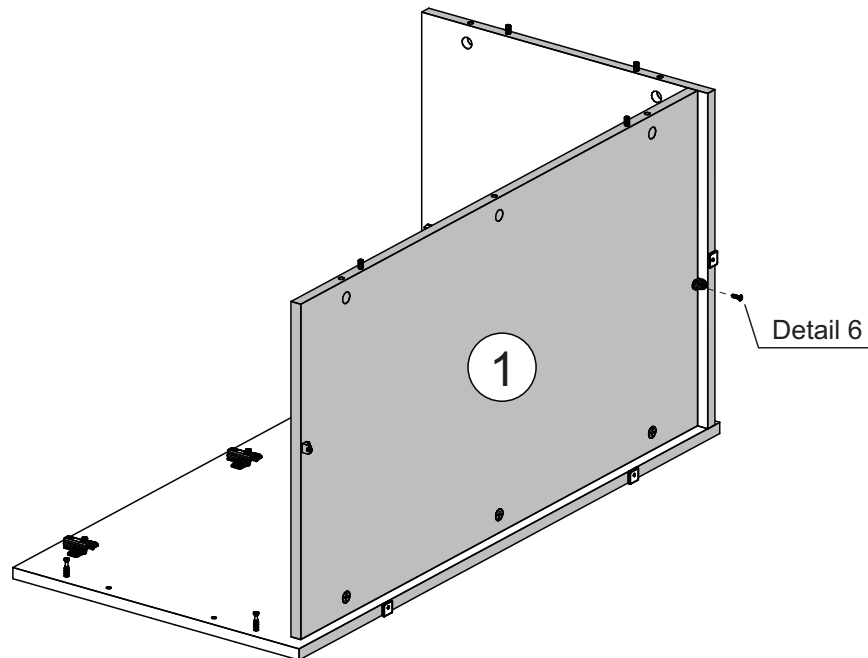
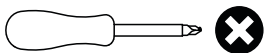

Detail 6

# STEP 9

## PARTS REQUIRED

2 - SIDE PANEL x1

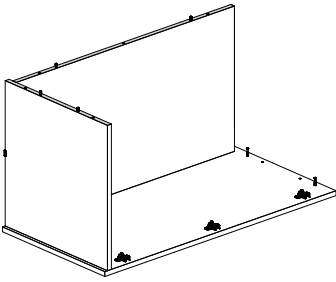

## HARDWARE REQUIRED

G  02

J  01

## TOOLS REQUIRED

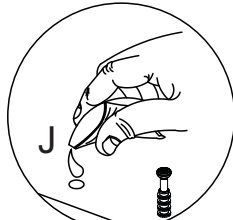
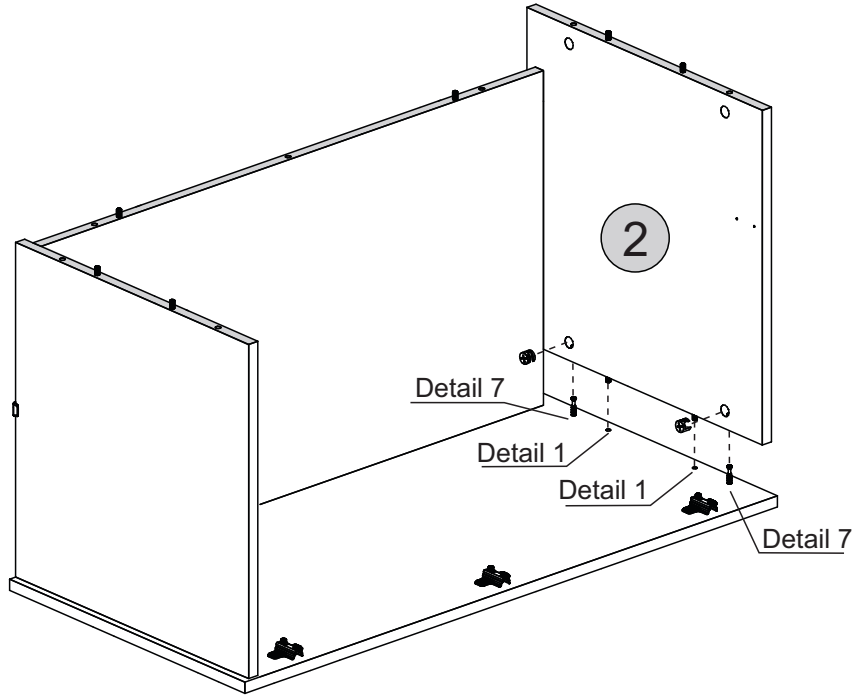
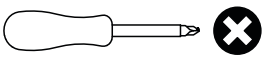

Detail 1

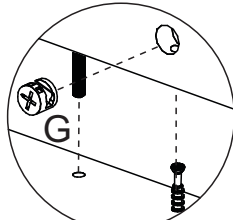

Detail 7

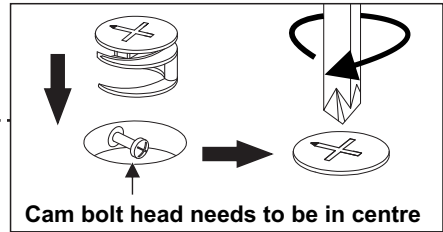

Cam bolt head needs to be in centre

# STEP 10

## PARTS REQUIRED

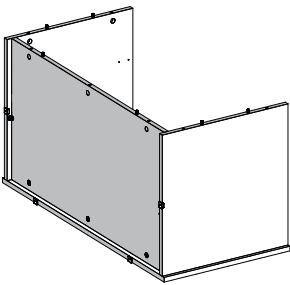

## HARDWARE REQUIRED

B  01  
Ø4.0 x 14mm

## TOOLS REQUIRED

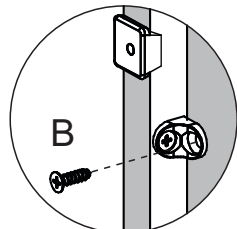
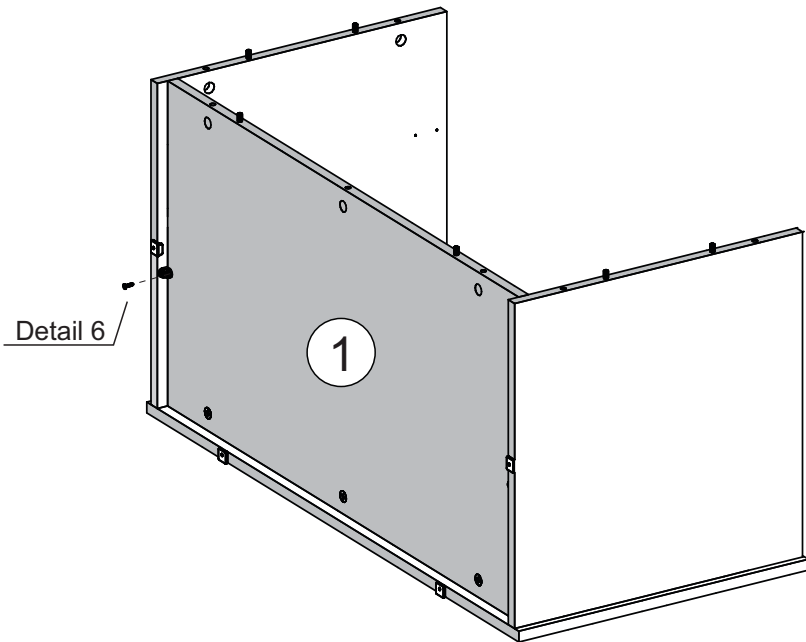
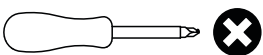

Detail 6



# STEP 11

## PARTS REQUIRED

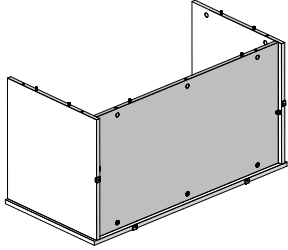

3 - FRONT PANEL x1

## HARDWARE REQUIRED

G  07

J  01

## TOOLS REQUIRED

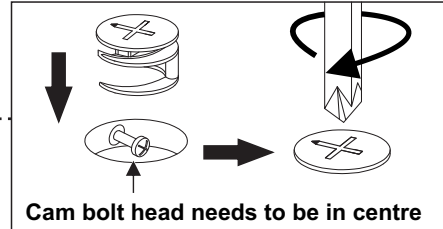
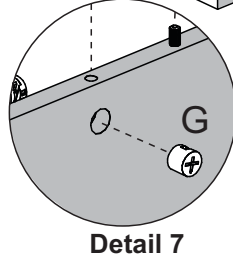
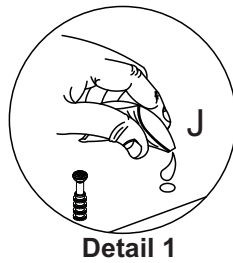
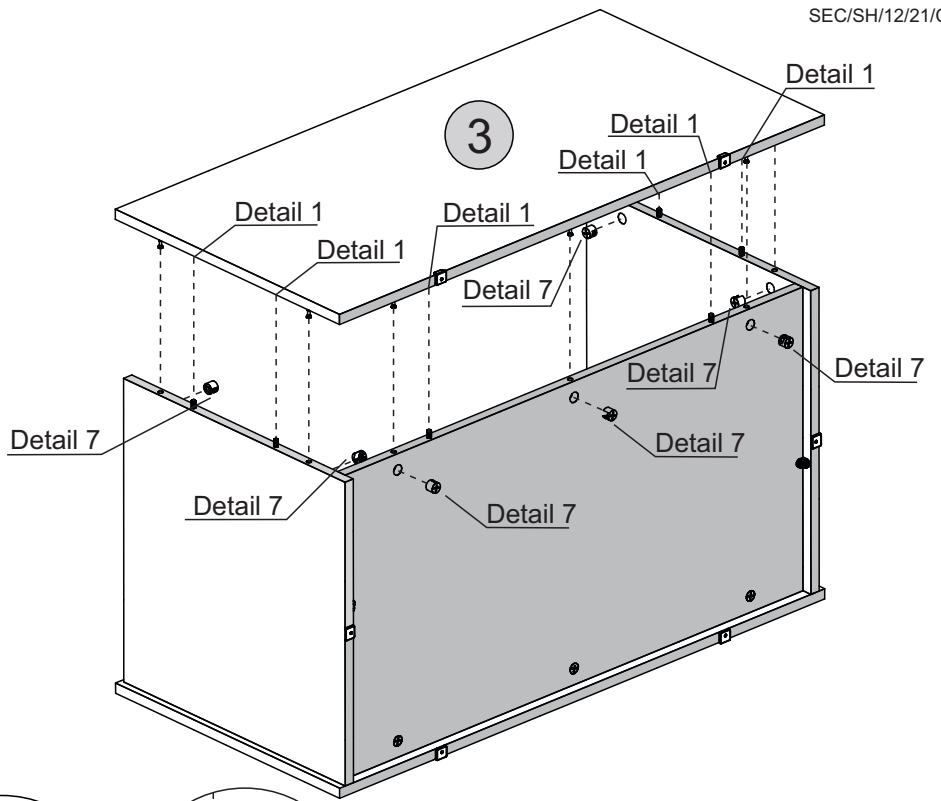
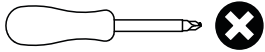

# STEP 12

## PARTS REQUIRED

5 - TOP PANEL x1

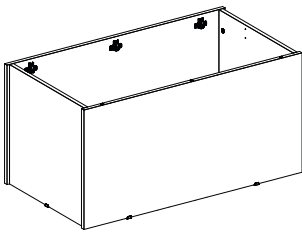

## HARDWARE REQUIRED

I  08

## TOOLS REQUIRED

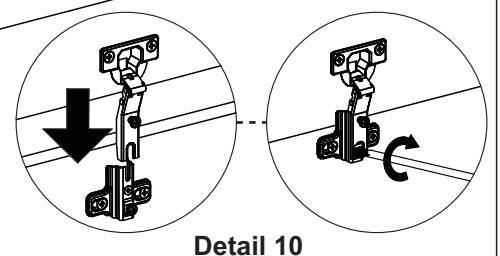
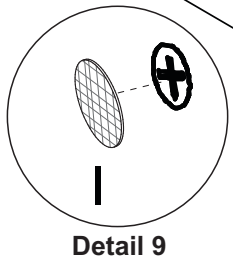
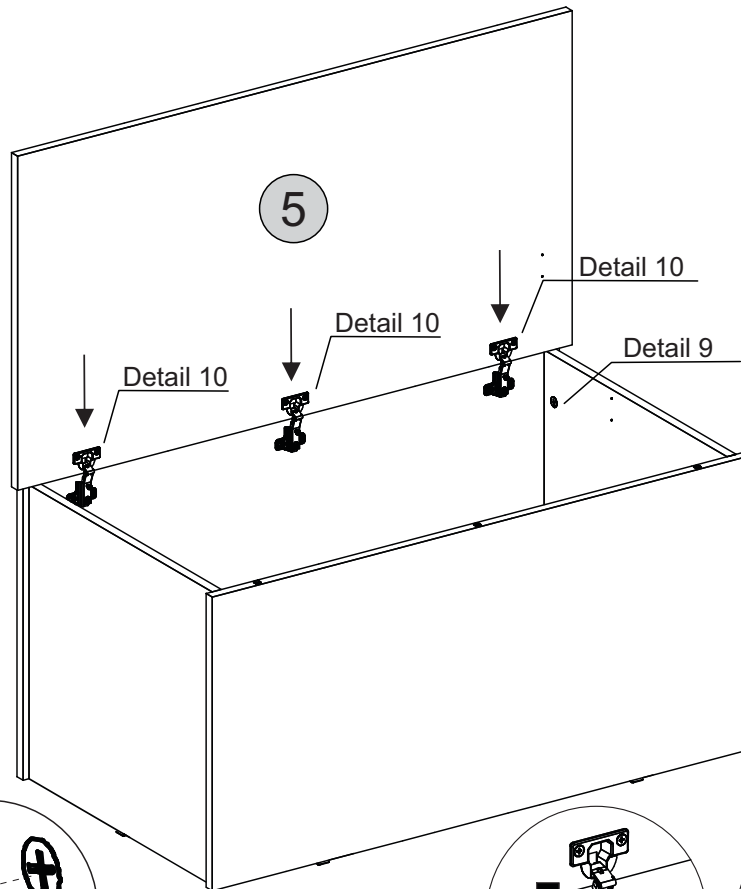
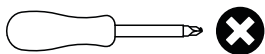

# STEP 13

## PARTS REQUIRED

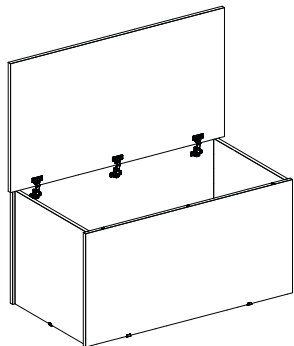

## HARDWARE REQUIRED

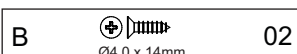
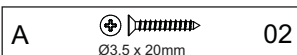

## TOOLS REQUIRED

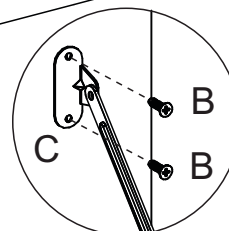
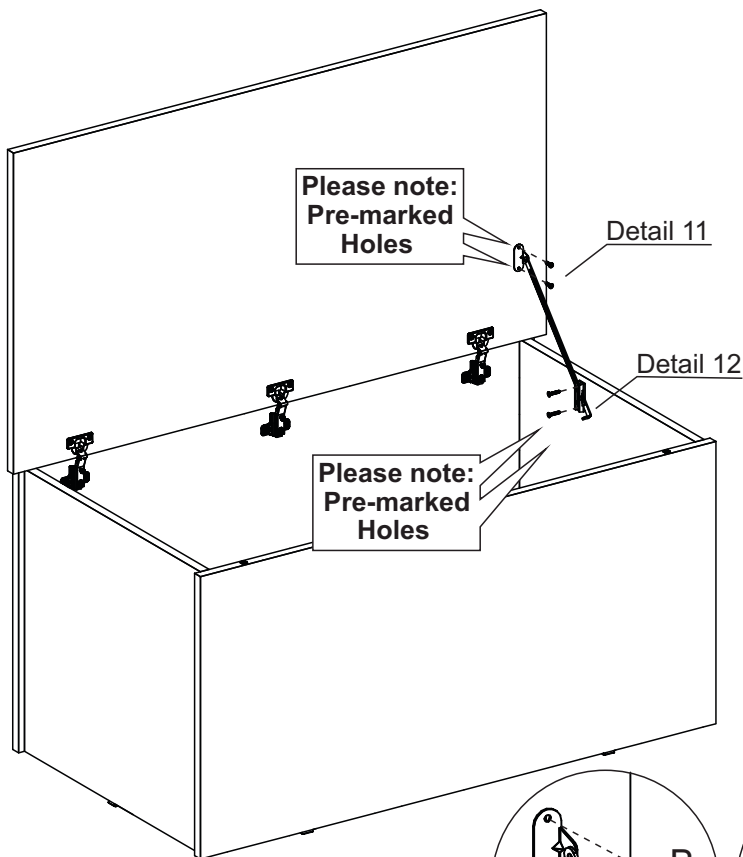
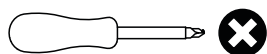

Detail 11

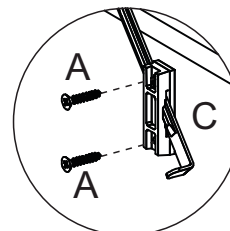

Detail 12

